

第六代KQL/KQW系列 立式/卧式单级单吸离心泵

Generation-6KQL/KQW
Series Single Stage
Vertical / horizontal Centrifugal Pump

- 外型美观
覆膜砂精密铸造, 铸件表面电泳漆
- 效率高
宽高效水力模型, 闭式铸铁叶轮
- 可靠性强、寿命长
泵与电机同轴, 旋转精度高, SKF轴承, 不锈钢轴套与博格曼或约翰克兰机封配合永不生锈, 整机加工中心加工
- 型谱范围广、选型方便



购买凯泉水泵4008-316-91

上海凯泉泵业(集团)有限公司
SHANGHAI KAIQUAN PUMP (GROUP) CO., LTD.

CONTENTS

目录

Empower
Water
Empower
Future

用途	02
使用条件	03
型号说明及材质	04
结构	05
电机及泵机组优点	06
供货范围及订货须知	07
型谱图	08
KQL 结构图及 KQW 结构图	09
性能曲线图、参数表、安装尺寸图	10
附件及安装基础尺寸图标	100
KQL 泵的安装方式	102
与原型号对照表	104

购买凯泉水泵4008-316-91

WORKING CONDITIONS 使用条件

转速: 2960r/min, 1480r/min, 980r/min

流量范围: 8~1400m³/h

扬程: ≤127m

介质温度: -25°C~80°C

80°C~120°C (耐高温机封、O形密封圈)

环境温度: 最大+40°C; 海拔高度小于1000m; 相对湿度不超过95%

最大工作压力(承压)

型号	工作压力	测试压力	承压零件材质
125口径(2极转速)及125口径以下	1.6MPa	2.1 MPa	灰铁
125~250口径(4极转速)	1.2MPa	1.6MPa	灰铁
300口径及300口径以上	1 MPa	1.3MPa	灰铁
125口径(4极转速)及125口径以上	1.6MPa	2.1MPa	球铁, 订货需注明

最大工作压力=进口压力+闭阀压力(Q=0) 最大进口压力

型号	扬程 (m)	最大进口压力 (MPa)	
		标准配置	球铁泵壳、高压机封
125口径(2极转速)及125口径以下	≤40	1.2	/
	≤60	1	/
	≤80	0.8	/
	≤125	0.4	/
125~250口径(4极转速)	≤20	1	/
	≤40	0.8	1.2
	≤60	0.6	1
300口径及300口径以上	≤80	0.4	0.8
	≤20	0.8	1.2
	≤40	0.6	1.2
	≤60	0.4	1
	≤80	0.2	0.8

125口径(2极转速)及125口径以下小口径泵无需采用球铁材质, 公司无表中打“/”的配置。

汽蚀余量是设计点实测值, 实际使用时应加0.5m的安全裕量。可选配PN16-GB/T17241.6-2008配对法兰。

Speed: 2960r/min, 1480r/min or 980r/min

Capacity range: 8~1400m³/h

Head: Up to 127m

Medium temperature: -25°C~80°C

Ambient temperature: Up to +40°C;

Altitude < 1000m; relative humidity ≤ 95%

Maximum working pressure:

Suction and discharge diameters are 125mm (2 pole speed) and below 125mm: 1.6Mpa;

Suction and discharge diameters are 125mm (4 polespeed) and 150-250mm: 1.2Mpa;

Suction and discharge diameters are greater than or equal to 300mm: 1.0Mpa;

Maximum operation pressure=Inlet pressure +valve shutting pressure.

DEFINITION 型号说明

例如: 80KQL50-32-7.5/2或80KQW50-32-7.5/2

KQL标准立式单级泵, KQW标准卧式单级泵

80 进出口直径

50 额定点流量

32 额定点扬程

7.5/2电机功率/电机极数

KQL: Standard vertical single-stage pump

KQW: Standard horizontal single-stage pump

80: Suction and discharge nozzle nominal diameters

50: Capacity at rated point

32: Head at rated point

7.5/2: Motor power/motor pole

DEFINITION 材质

主要部件 MAIN PARTS	型号配置 MODEL	KQL 或 KQW	KQL /T或KQW/T
电机系列 MOTOR		YE3系列超效率三相异步电动机, Three-phase induction motor series	按用户要求 According to the customer's needs
泵轴材料 SHAFT		45#钢 45#	
轴套材料 Shaft sleeve		304	
轴承 BEARING		进口名牌 SKF (4KW 及以下 NSK)	
机械密封 MECHANICAL SEAL		品牌 (35轴径及以下为国内知名品牌, 45轴径及以上为进口品牌) famous brand	
铸件 CASTING		优质铸件 Quality casting	
表面处理 SURFACE DISPOSE		电泳漆	

泵体、泵盖、叶轮: 铸铁

泵轴: 45#钢

机械密封动、静环: 浸钨石墨、碳化硅

Materials Casing, Cover, Impeller : Cast iron

Shaft : 45#

Motive, motionless ring of mechanical seal: Graphite, harden alloy

STRUCTURE 结构

结构紧凑的单级泵,是最适用于现代建筑物的。

Compact single -stage pump is especially suitable for modern

——立式泵壳

管理连接型式的螺旋形泵壳,采用现代最优水力模型设计制造,进出口在同一直线上,且口径相同。法兰符合GB/T17241.6-2008并可选配Rp1/4或Rp3/8测压口。

——Casing

It has pipe joined spiral casing and uses the best hydraulic model. Suction and discharge nozzles are in one line with the same diameter. Flange accords with the standard of GB/T17241 .6-1998 and may choose to be fixed with Rp1/4 or Rp3/8 pressure gauge.

——卧式泵壳

泵脚支承型式的螺旋形泵壳,采用现代最优水力模型设计制造,水平吸入上方输出。法兰符合GB/T17241.6-2008并可选配Rp1/4或Rp3/8测压口。

——Casing

It has pipe joined spiral casing and uses the best hydraulic model. Suction and discharge nozzles are in one line. Flange accords with the standard of GB/T17241.6-1998 and may choose to be fixed with Rp1/4 or Rp3/8 pressure gauge.

——叶轮

闭式叶轮,优秀的水力模型保证泵的效率 and 可靠性,部分改进型号泵的配套功率下降一档。

——Impeller

Closed cast iron impeller. Best hydraulic model guarantees the efficiency and reliability of the pump.

机械密封 Mechanical seal

——系列产品

用于水温80C以下,免保养,不受转向限制。特殊波纹管设计保证了动环的补偿性和密封性能。

——Series product

If the pump operates in the water with temperature below 80°C, it needn't maintain and will not be limited by rotating direction. Special bellows design guarantees the compensation and hermetic function of the dynamic ring.

MOTOR 电机

YE3系列高效率三相异步电动机系列。功率和型式符合IEC-Norm。

型式: V1 (KQL) B35 (KQW)

电源: 380V, 50HZ

防护等级: IP55

绝缘等级: F

电机轴: 45#钢(密封位304)或不锈钢(2Cr13)

温度:电机工作环境温度最大到40°C。温度高于40°C时,请降低功率使用。

转向:立式泵从电机风叶端向下看为顺时针方向,卧式泵从泵进口方向看为逆时针方向。

Squirrel three-phase induction motor series.

Efficiency and type accord with ICE-Norm.

Power source: 380V, 50HZ

Protection class: IP55

Insulation: F

Shaft of the motor: Stainless steel(2Cr13)

Temperature: Maximum temperature of working environment is 40°C. Above 40°C, please decrease the power.

ADVANTAGES 泵机组优点

——采用电机直接连接,机泵轴完全同心,振动小、噪音低

——泵进出口口径相同,运行稳定可靠。

——用整轴和特殊结构配置的SKF轴承,运行可靠。

——用强制环流的不受转向限制的特殊结构配置的机械密封,改善其运行环境,延长使用寿命。

——独特的安装结构大大缩小了泵的占地面积,节约建设投资40%~60%。

——完美的设计确保泵的无泄漏,长寿命运行,节约运行管理费50%~70%。

——采用优质铸件,尺寸精度高,外形美观。

电机优点

——采用更新设计的高效率三相异步电动机系列,结构更加合理,外形新颖美观。

——启动转矩大,效率高,噪音小。

——F级绝缘,提高了电机使用的最高允许温升,因而抗过载能力高,耐力强,使用安全可靠,寿命延长。

——IP55全封闭结构,防止粉尘、风雨、飞溅水滴等进入电机内部,造成电机损坏。

——密封位不锈钢,永不生锈,保证配合零件拆装简便,机械密封波纹管密封可靠。

- Directly connected with the motor. the axle of motor and pump share the same shaft. Less vibration, Low noise.
- The outlet and inlet are same in diameter and the diameters are in the same line. Liquid flows smoothly with less loss.
- Removal of baseplate. Just like valves, the pump can be mounted wherever on the pipe line.
- The whole shaft and special structured configuration bearing runs reliably.
- The mechanical seal, which applies the configuration of end-to-end circulation and no direct-connection limited special structure, improves the running environment and elongates the service life.
- Unique installation reduces the occupation of pump, which saves the investment cost by 40% to 60%.
- Perfect design makes sure of no leakage, long life, which saves operation cost by 50% to 70%.
- Adopt the high-quality casting process, which results in high accuracy in dimension and nice-looking appearance.

Motor Advantages

- Adopt the modified Two-phase induction, the structure is more reasonable and, rational and nice-looking.
- The starting torque is large, the efficiency is high, the noise is low.
- F class insulation, which improves the permissible temperature rise of motor, thus resulting in high ability the antioverload, strong wear-resistant, and long service life.
- IP55 fully closed structure, which prevents dust, water drop, rain (with cover) from entering the motor to damage the motor.
- Rotating shaft made of stainless material; will never be rusty, which ensures that the components are easy to dismantle, and the ripple pipe of mechanical seal is reliable.

SUPPLY ARRANGE
供货范围

水泵带底座(板)和安装使用说明书
Pump and installation instructions are available.

NOTES ON ORDER-PLACING
订货须知

1. 输送特殊液体时, 请在合同中注明液体的名称、温度、密度、浓度、粘性等, 以便制造厂合理选配材质和电机功率。
 2. 当对流量、扬程、进口压力、电机电压、频率、防爆等有特殊要求时, 请在合同中注明。
1. Name, temperature, density, concentration, trellises should be clearly noted in the contract when the transporting media is corrosive, so that the manufacturer can make a proper choice of material and power of motor.
 2. It should be clearly noted in the contract when special requirement, for instance, capacity, suction pressure, head, motor, voltage, frequency, blast-proof etc, are made.

HYDRAULIC COVERAGE
型谱图

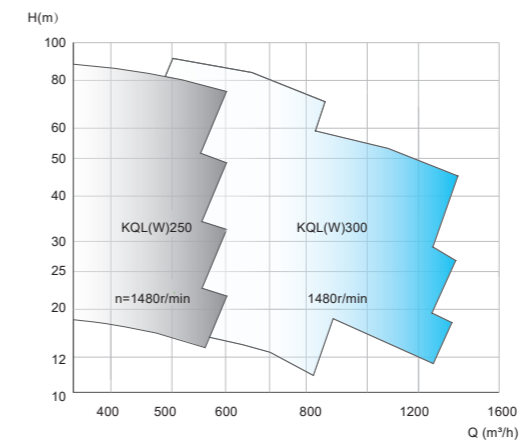
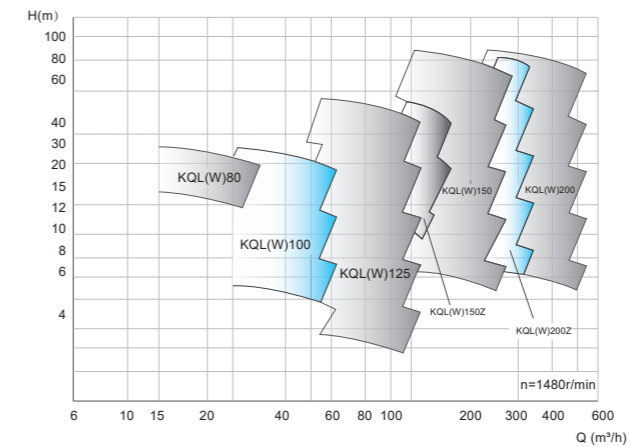
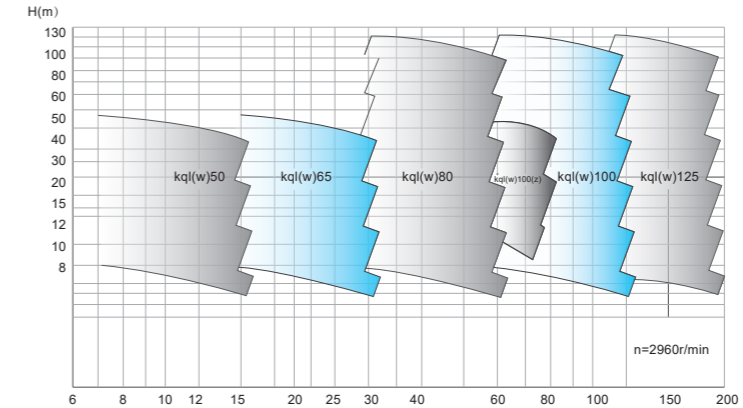

STRUCTURE DIAGRAM
结构图

KQL结构图 KQL STRUCTURE DRAWING

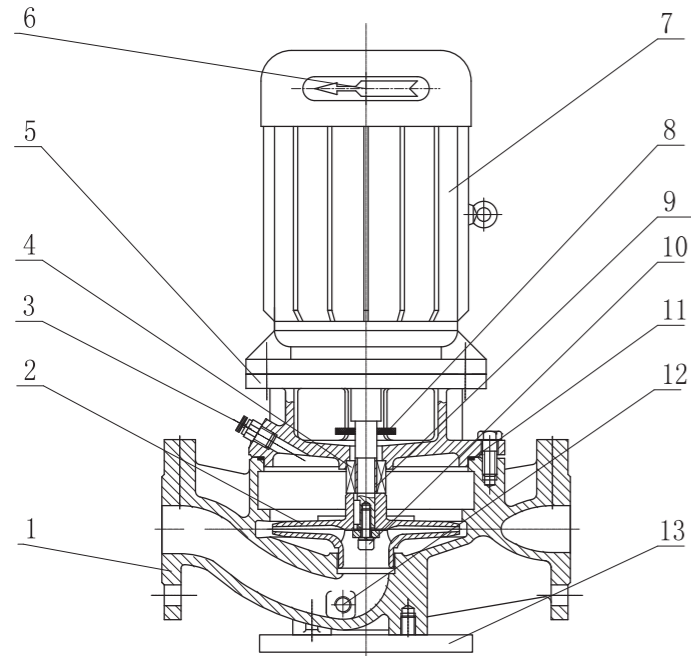

序号 No.	数量 QUANTITY	名称 NAME
1	1	泵体 Casing
2	1	叶轮 Impeller
3	1	放气旋塞 Air discharge valve
4	1	机械密封 Mechanical seal
5	1	泵盖 Casing cover
6	1	转向牌 Chang direction plate
7	1	电机 Motor
8	1	挡水圈 Deflector
9	1	不锈钢轴套 Shaft sleeve
10	1	螺钉 Screw
11	1	O形密封圈 O seal ring
12	1	螺塞 Plug
13	1	底板 Baseplate

CHARACTERISTIC CURVE
性能曲线

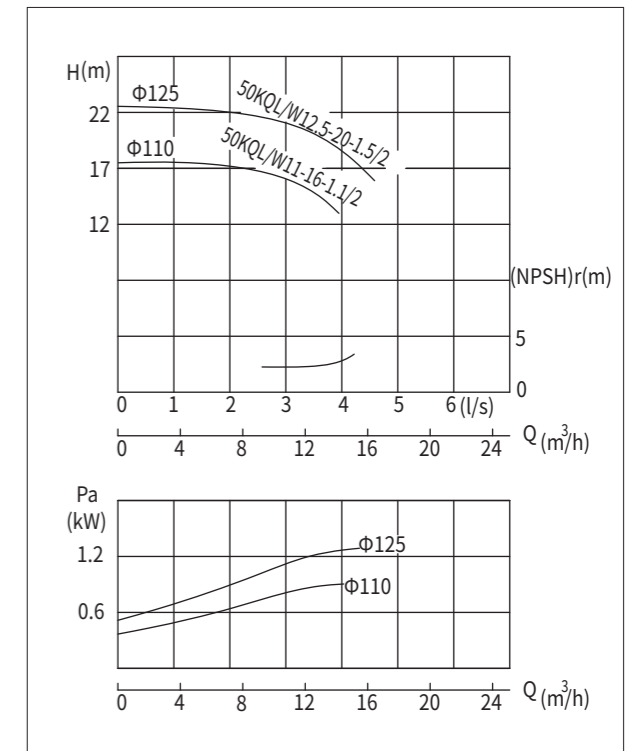
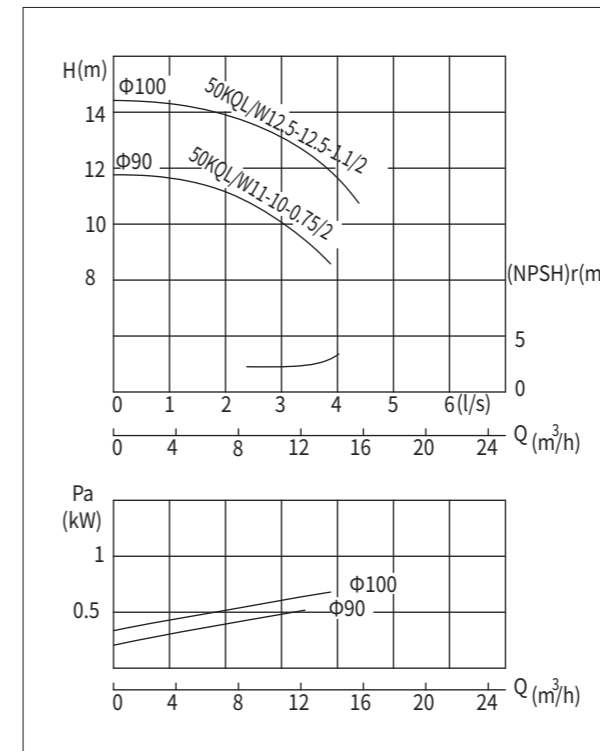

KQW结构图 KQW STRUCTURE DRAWING

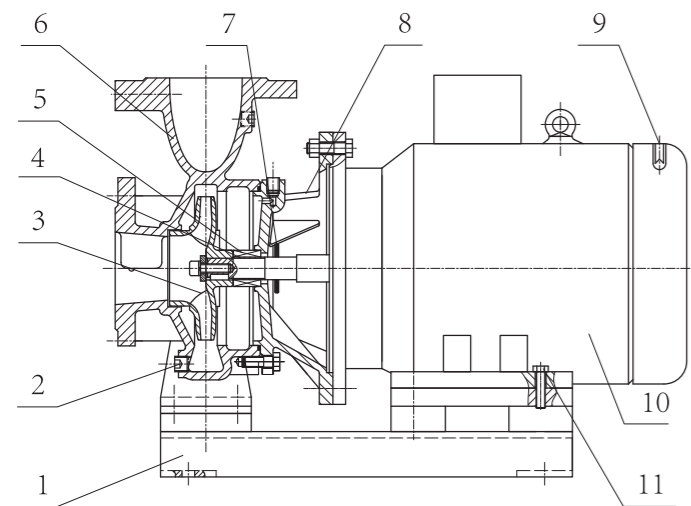

序号 (NO.)	数量 QUANTITY	名称 NAME
1	1	底座 Bedplate
2	3	螺塞 Screwed plug
3	1	叶轮 Impeller
4	1	不锈钢轴套 Shaft sleeve
5	1	机械密封 Mechanical seal
6	1	泵体 Pump body
7	1	挡水圈 Deflector
8	1	泵盖 Pump Cover
9	1	转向牌 Chang direction plate
10	1	电动机 Motor
11	8	螺栓 Bolt

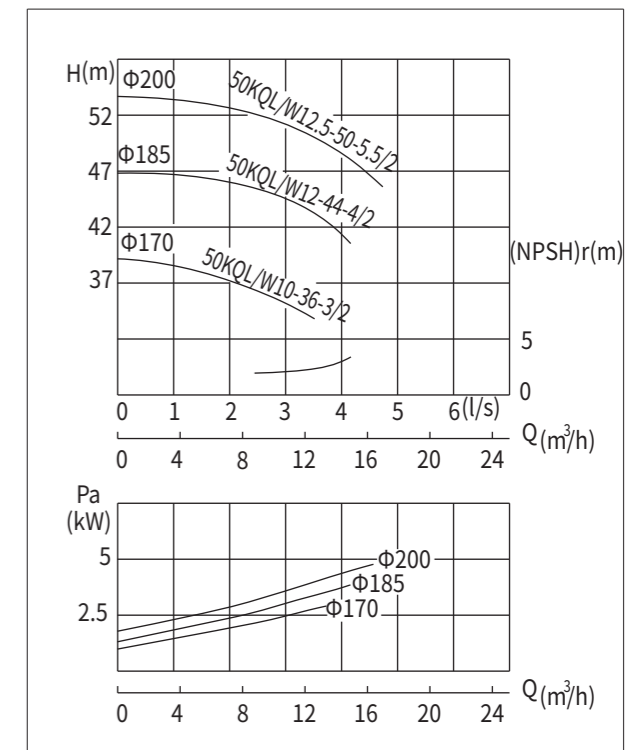
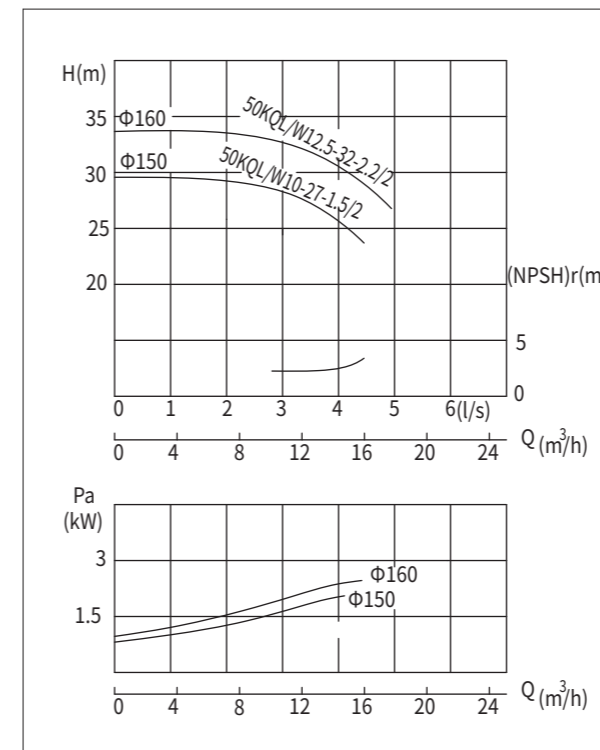

PERFORMANCE DATA
参数表

型号 TYPE	流量 Capacity		扬程 Head (m)	转速 Speed (r/min)	效率 Efficiency (%)	电机 功率 Power (kW)	必需 汽蚀 余量 (NPSH)r (m)	重量 Weight (kg)
	(m ³ /h)	(l/s)						
50KQL/W11-10-0.75/2	8	2.22	11	2960	66	0.75	2.3	38
	11	3.05	10					
	13.2	3.67	9					
50KQL/W12.5-12.5-1.1/2	8.8	2.44	13.6	2960	66.2	1.1	2.3	40
	12.5	3.47	12.5					
	15	4.17	11.3					
50KQL/W11-16-1.1/2	8	2.22	17	2960	61	1.1	2.3	40
	11	3.05	16					
	13.2	3.67	14					
50KQL/W12.5-20-1.5/2	8.8	2.44	21.5	2960	62.1	1.5	2.3	48
	12.5	3.47	20					
	15	4.17	17.8					
50KQL/W10-27-1.5/2	7.0	1.94	28.35	2960	55	1.5	2.3	51
	10	2.78	27					
	11.0	3.06	26.2					
50KQL/W12.5-32-2.2/2	8.8	2.43	33.6	2960	56	2.2	2.3	59
	12.5	3.47	32					
	13.8	3.82	30					
50KQL/W10-36-3/2	7.3	2.02	38	2960	48	3	2.3	65
	10.4	2.89	36					
	12.5	3.47	33					
50KQL/W12-44-4/2	8.3	2.31	45.8	2960	49	4	2.3	80
	11.7	3.25	44					
	14.0	3.89	42					
50KQL/W12.5-50-5.5/2	8.8	2.43	52	2960	49.5	5.5	2.3	105
	12.5	3.47	50					
	15.0	4.17	48					

DIMENSION FIGURE
尺寸图

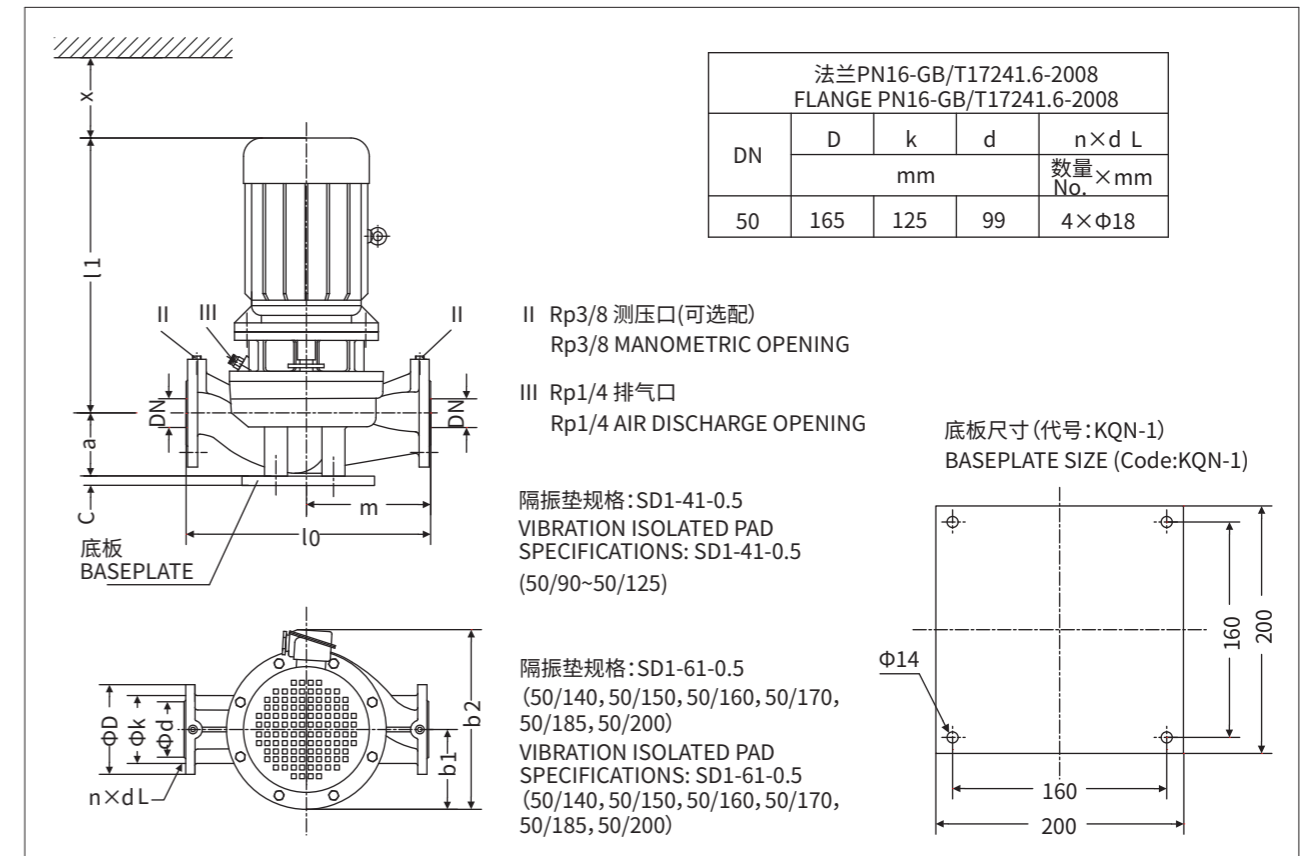

DIMENSION TABLE
KQL尺寸表

型号 TYPE	DN	l ₀	m	a	c	l ₁	b ₁	b ₂	x
50KQL11-10-0.75/2	50	370	185	115	24	395	120	265	100
50KQL12.5-12.5-1.1/2	50	370	185	115	24	395	120	265	100
50KQL11-16-1.1/2	50	370	185	115	24	395	120	265	100
50KQL12.5-20-1.5/2	50	370	185	115	24	440	120	280	100
50KQL10-27-1.5/2	50	370	185	115	24	440	120	280	100
50KQL12.5-32-2.2/2	50	370	185	115	24	470	120	280	100
50KQL10-36-3/2	50	380	190	127	24	513	155	325	120
50KQL12-44-4/2	50	380	190	127	24	548	155	345	120
50KQL12.5-50-5.5/2	50	380	190	127	24	578	185	400	120

DIMENSION FIGURE
尺寸图

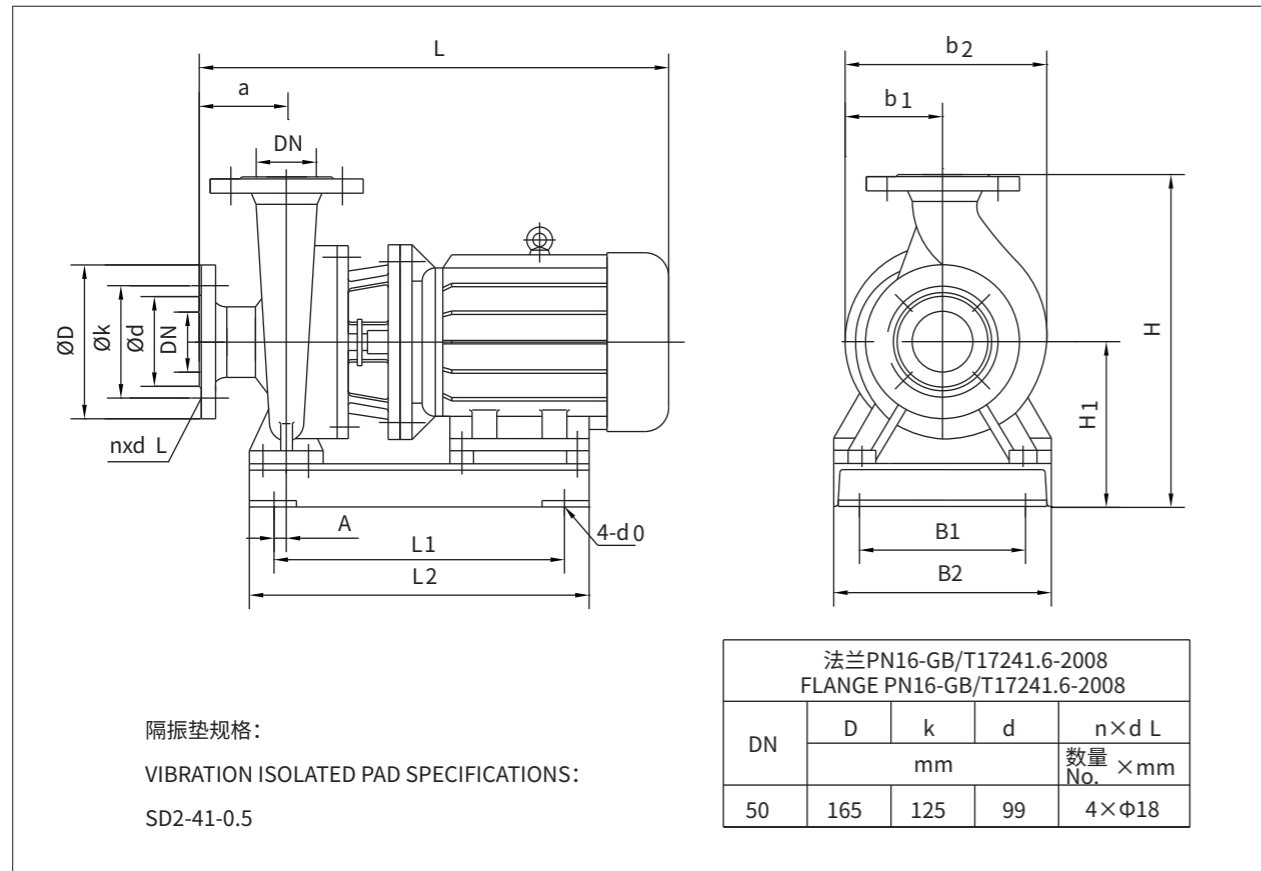

DIMENSION TABLE
KQW尺寸表

型号 TYPE	外形尺寸 Figure dimensions				安装尺寸 Installing dimensions								DN
	L	H	b2	b1	4-d0	a	L1	B1	L2	B2	H1	A	
50KQW11-10-0.75/2	475	379	250	125	4-φ12	80	245	160	360	250	219	0	50
50KQW12.5-12.5-1.1/2	475	379	250	125	4-φ12	80	245	160	360	250	219	0	50
50KQW11-16-1.1/2	475	379	250	125	4-φ12	80	245	160	360	250	219	0	50
50KQW12.5-20-1.5/2	520	379	250	125	4-φ12	80	255	160	360	250	219	0	50
50KQW10-27-1.5/2	520	379	250	125	4-φ12	80	255	160	360	250	219	0	50
50KQW12.5-32-2.2/2	550	379	250	125	4-φ12	80	280	160	385	250	219	0	50
50KQW10-36-3/2	613	502	320	160	4-φ15	100	325	220	425	320	277	12.5	50
50KQW12-44-4/2	648	502	320	160	4-φ15	100	335	220	435	320	277	12.5	50
50KQW12.5-50-5.5/2	678	502	320	160	4-φ15	100	370	220	470	320	277	12.5	50

CHARACTERISTIC CURVE
性能曲线

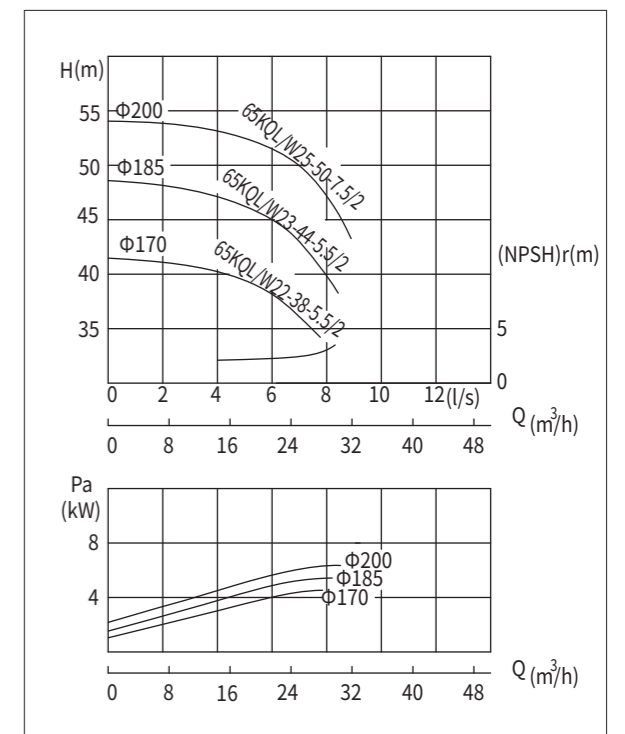
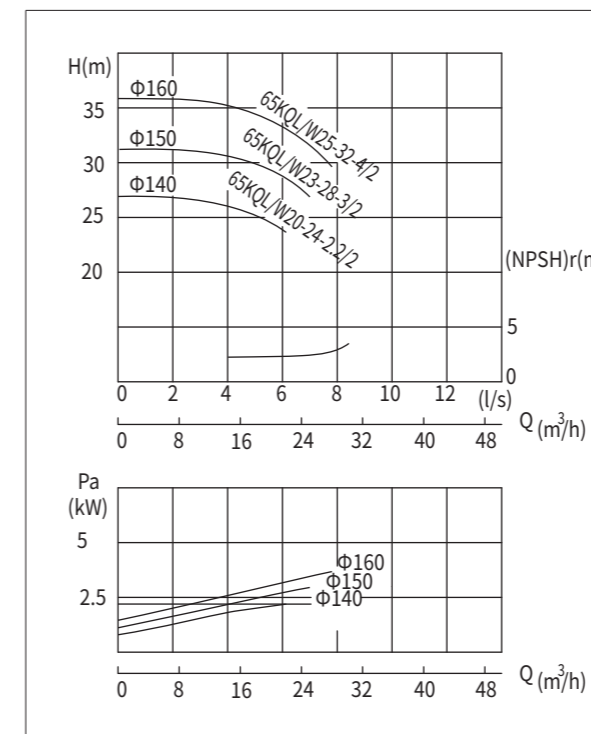
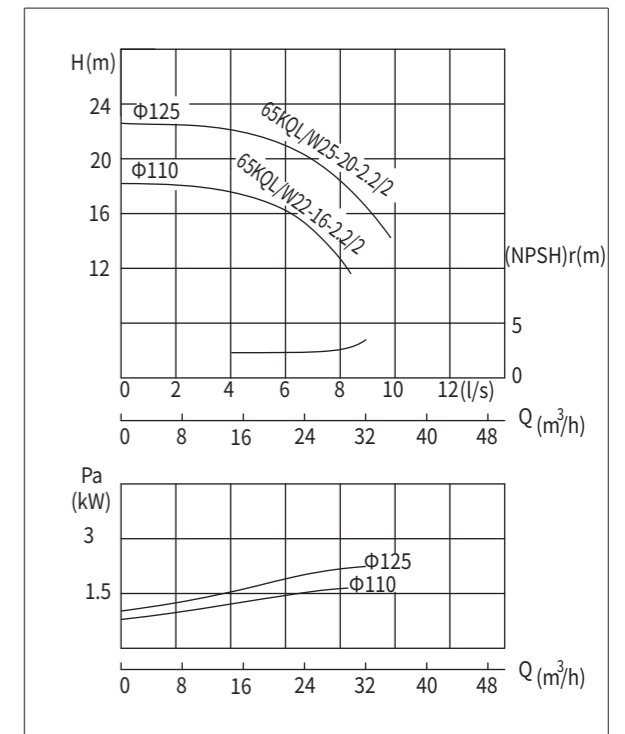
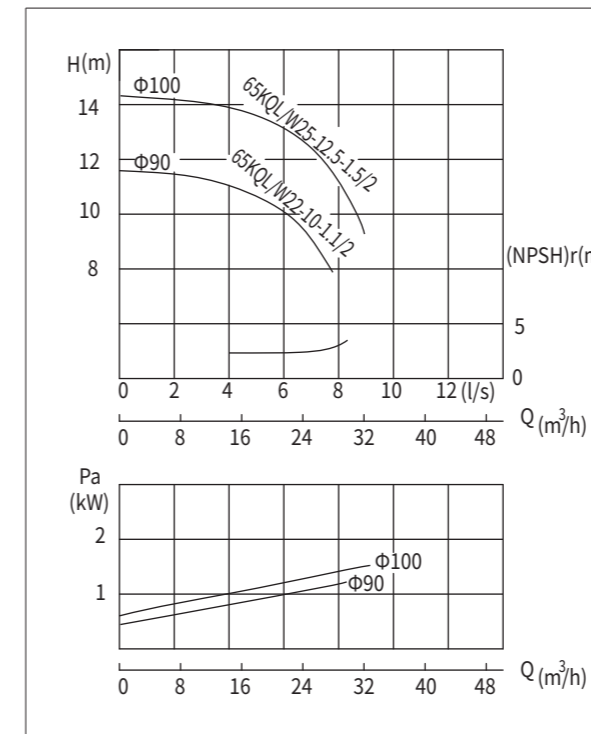

PERFORMANCE DATA
参数表

型号 TYPE	流量 Capacity		扬程 Head (m)	转速 Speed (r/min)	效率 Efficiency (%)	电机 功率 Power (kW)	必需 汽蚀 余量 (NPSH)r (m)	重量 Weight (kg)
	(m ³ /h)	(l/s)						
65KQL/W22-10-1.1/2	15.6	4.3	11	2960	65	1.1	2.5	31
	22.3	6.19	10					
	27	7.5	8.4					
65KQL/W25-12.5-1.5/2	17.5	4.86	13.7	2960	65.5	1.5	2.5	53
	25	6.94	12.5					
65KQL/W22-16-2.2/2	15.6	4.3	17	2960	65	2.2	2.5	58
	22.3	6.19	16					
65KQL/W25-20-2.2/2	17.5	4.86	21	2960	71.4	2.2	2.5	64
	25	6.94	20					
65KQL/W20-24-2.2/2	14	3.89	25.2	2960	65	2.2	2.5	64
	20	6	24					
65KQL/W23-28-3/2	16.1	4.47	29.4	2960	66	3	2.5	75
	23	6.5	28					
65KQL/W25-32-4/2	17.5	4.86	34.3	2960	66.7	4	2.5	73
	25	6.94	32					
65KQL/W22-38-5.5/2	15.2	4.22	40	2960	57	5.5	2.5	124
	21.8	6.06	38					
65KQL/W23-44-5.5/2	16.4	4.55	46.2	2960	58	5.5	2.5	124
	23.4	6.5	44					
65KQL/W25-50-7.5/2	17.5	4.86	52.7	2960	59	7.5	2.5	124
	25	6.94	50					
	30	8.33	45.5					

DIMENSION FIGURE
尺寸图

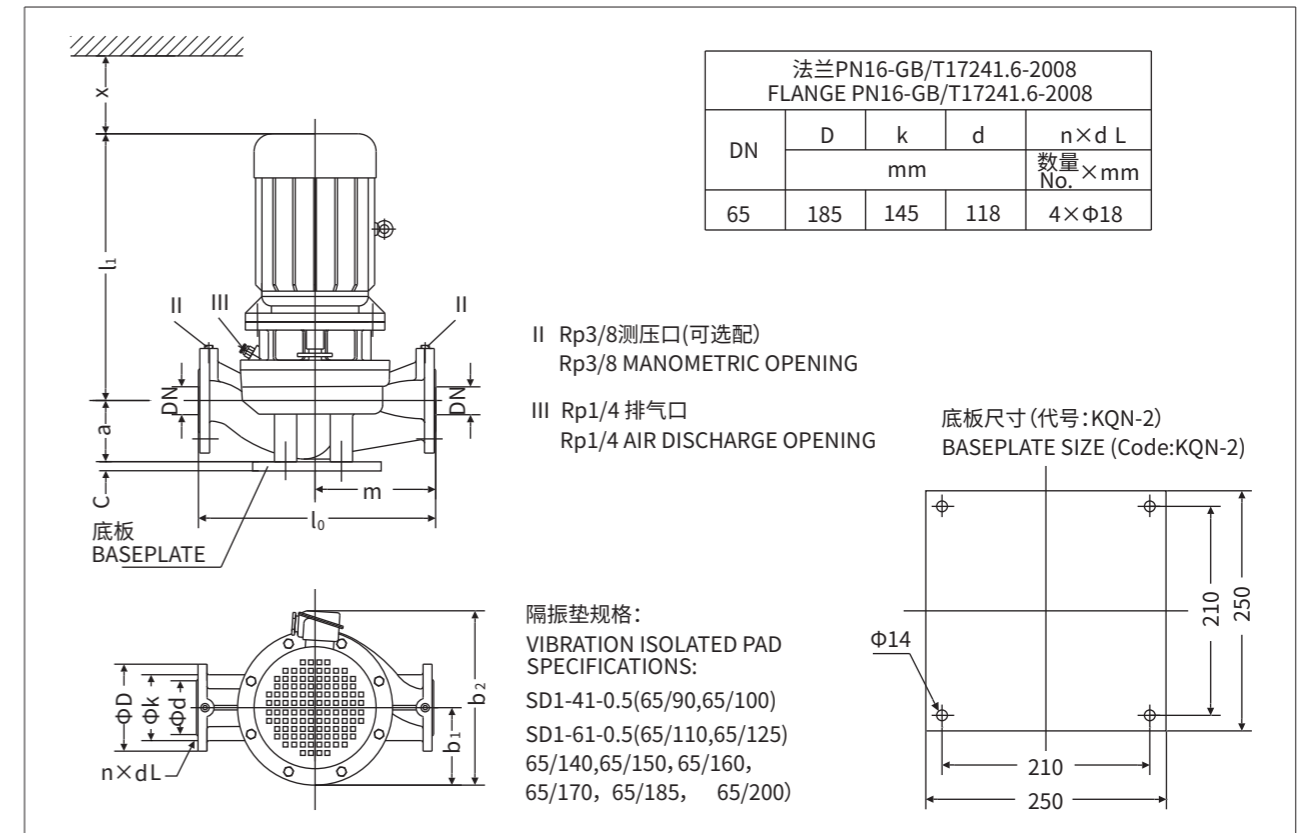

DIMENSION TABLE
KQL尺寸表

型号 TYPE	DN	l ₀	m	a	c	l ₁	b ₁	b ₂	x
65KQL22-10-1.1/2	65	420	210	130	30	395	120	265	105
65KQL25-12.5-1.5/2	65	420	210	130	30	440	120	280	105
65KQL22-16-2.2/2	65	420	210	130	30	470	120	280	105
65KQL25-20-2.2/2	65	420	210	130	30	470	120	280	105
65KQL20-24-2.2/2	65	420	210	130	30	470	120	280	105
65KQL23-28-3/2	65	420	210	130	30	505	125	295	105
65KQL25-32-4/2	65	420	210	130	30	540	125	315	105
65KQL22-38-5.5/2	65	400	200	150	30	577	185	400	105
65KQL23-44-5.5/2	65	400	200	150	30	577	185	400	105
65KQL25-50-7.5/2	65	400	200	150	30	577	185	400	105

DIMENSION FIGURE
尺寸图

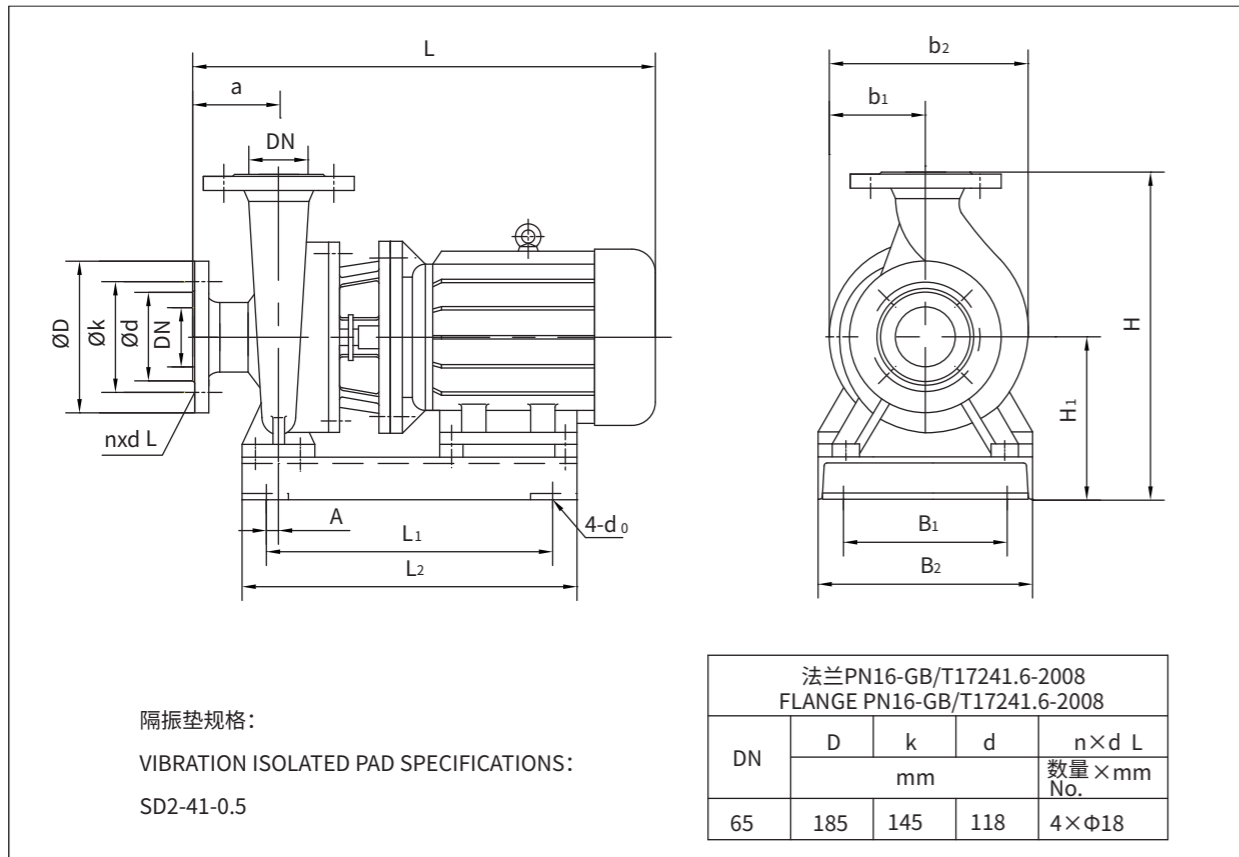

DIMENSION TABLE
KQW尺寸表

型号 TYPE	外形尺寸 Figure dimensions				安装尺寸 Installing dimensions								DN
	L	H	b2	b1	4-φd0	a	L1	B1	L2	B2	H1	A	
65KQW22-10-1.1/2	475	409	250	125	4-φ12	80	245	160	345	250	219	0	65
65KQW25-12.5-1.5/2	520	409	250	125	4-φ12	80	255	160	360	250	219	0	65
65KQW22-16-2.2/2	550	409	250	125	4-φ12	80	280	160	385	250	219	0	65
65KQW25-20-2.2/2	550	409	250	125	4-φ12	80	280	160	385	250	219	0	65
65KQW20-24-2.2/2	550	409	250	125	4-φ12	80	280	160	385	250	219	0	65
65KQW23-28-3/2	585	409	250	125	4-φ12	80	300	160	405	250	219	0	65
65KQW25-32-4/2	620	409	250	125	4-φ12	80	310	160	410	250	219	0	65
65KQW22-38-5.5/2	677	507	320	160	4-φ15	100	370	220	470	320	277	12.5	65
65KQW23-44-5.5/2	677	507	320	160	4-φ15	100	370	220	470	320	277	12.5	65
65KQW25-50-7.5/2	677	507	320	160	4-φ15	100	370	220	470	320	277	12.5	65

CHARACTERISTIC CURVE
性能曲线

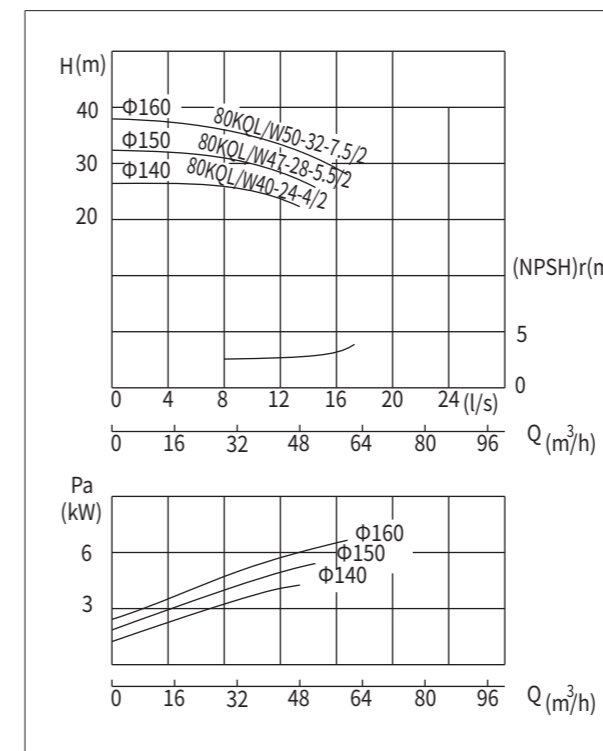
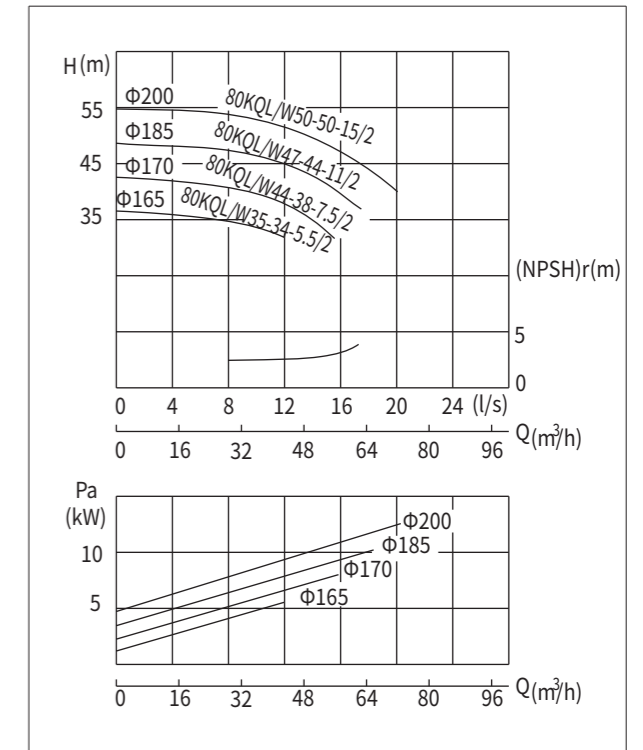
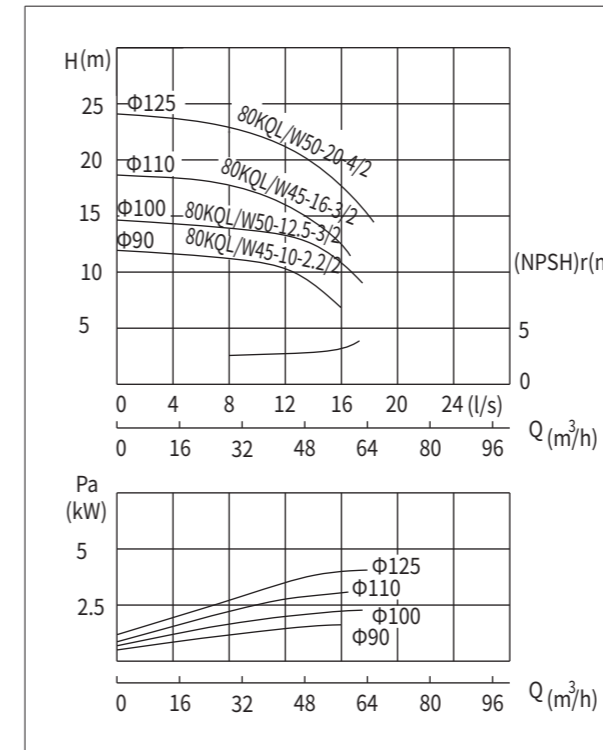

PERFORMANCE DATA
参数表

型号 TYPE	流量 Capacity		扬程 Head (m)	转速 Speed (r/min)	效率 Efficiency (%)	电机 功率 Power (kW)	必需 汽蚀 余量 (NPSH)r (m)	重量 Weight (kg)
	(m ³ /h)	(l/s)						
80KQL/W45-10-2.2/2	31.3	8.7	11.5	2960	72	2.2	3	63
	44.7	12.5	10					
	53.6	14.9	8					
80KQL/W50-12.5-3/2	35	9.72	14	2960	73	3	3	80
	50	13.9	12.5					
	60	16.7	10.1					
80KQL/W45-16-3/2	31.5	8.75	17.5	2960	76.4	3	3	79
	45	12.5	16					
	49.5	13.75	15					
80KQL/W50-20-4/2	35	9.72	21	2960	76.9	4	3	90
	50	13.9	20					
	55	15.28	18.3					
80KQL/W40-24-4/2	28	7.78	25.2	2960	75	4	3	90
	40	12	24					
	44	12.22	21.6					
80KQL/W47-28-5.5/2	32.69	9.08	30	2960	75	5.5	3	110
	46.7	13	28					
	51.37	14.27	25.8					
80KQL/W50-32-7.5/2	35	9.72	35	2960	75.4	7.5	3	113
	50	13.9	32					
	60	16.7	28					
80KQL/W35-34-5.5/2	24.5	6.81	35.7	2960	70	5.5	3	112
	35	9.72	34					
	38.5	10.69	32					
80KQL/W44-38-7.5/2	30.5	8.5	40.6	2960	70	7.5	3	115
	43.5	12.1	38					
	52	14.4	33.4					
80KQL/W47-44-11/2	32.8	9.1	47	2960	70	11	3	165
	47	13.1	44					
	56.4	15.7	40					
80KQL/W50-50-15/2	35	9.72	53.5	2960	71.4	15	3	185
	50	13.9	50					
	60	16.67	46					

DIMENSION FIGURE
尺寸图

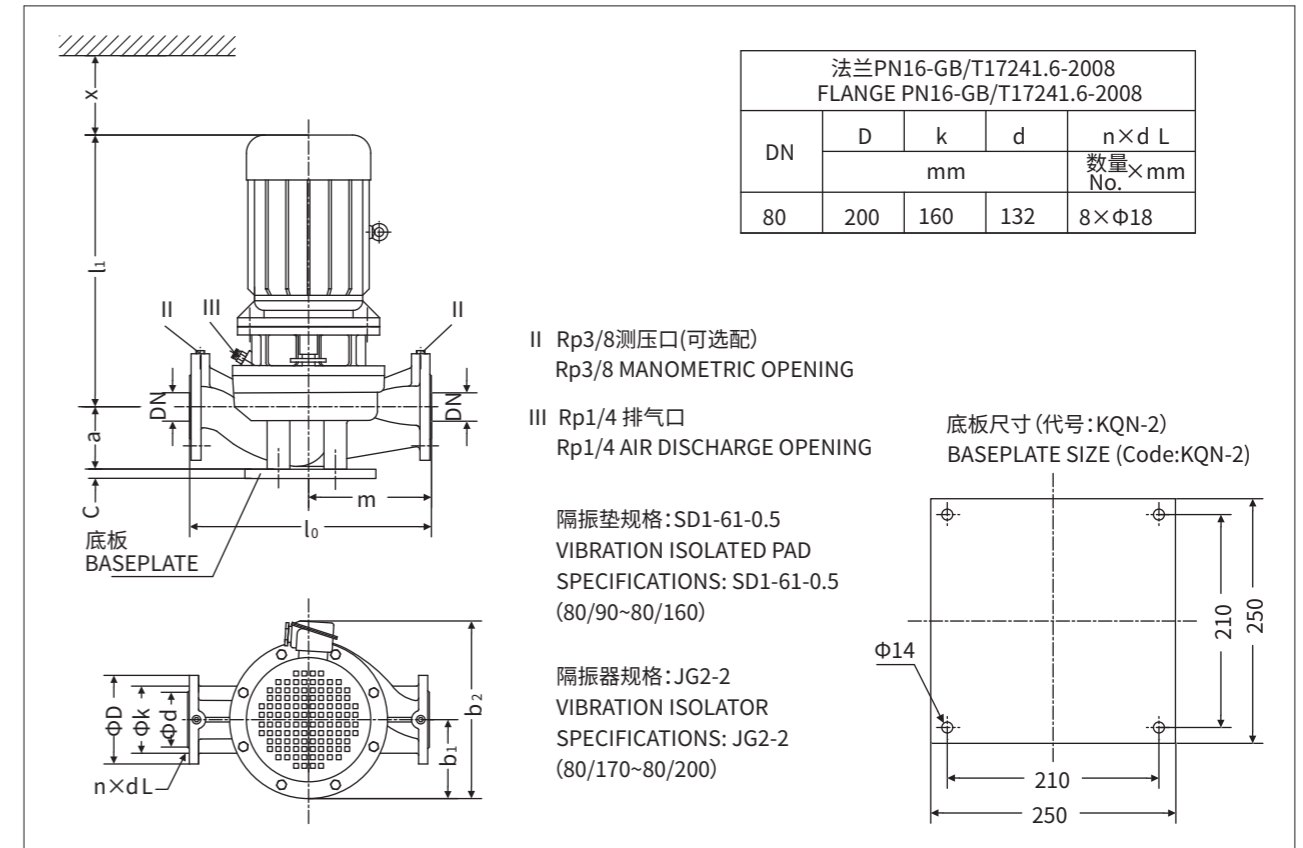

DIMENSION TABLE
KQL尺寸表

型号 TYPE	DN	l ₀	m	a	c	l ₁	b ₁	b ₂	x
mm									
80KQL45-10-2.2/2	80	490	245	145	30	470	120	290	110
80KQL50-12.5-3/2	80	490	245	145	30	505	125	295	110
80KQL45-16-3/2	80	490	245	145	30	505	125	295	110
80KQL50-20-4/2	80	490	245	145	30	540	125	315	110
80KQL40-24-4/2	80	490	245	145	30	540	125	315	110
80KQL47-28-5.5/2	80	490	245	145	30	560	185	400	110
80KQL50-32-7.5/2	80	490	245	145	30	560	185	400	110
80KQL35-34-5.5/2	80	490	245	145	30	560	185	400	110
80KQL44-38-7.5/2	80	540	270	155	30	577	185	400	120
80KQL47-44-11/2	80	540	270	155	30	705	225	485	120
80KQL50-50-15/2	80	540	270	155	30	705	225	485	120

DIMENSION FIGURE
尺寸图

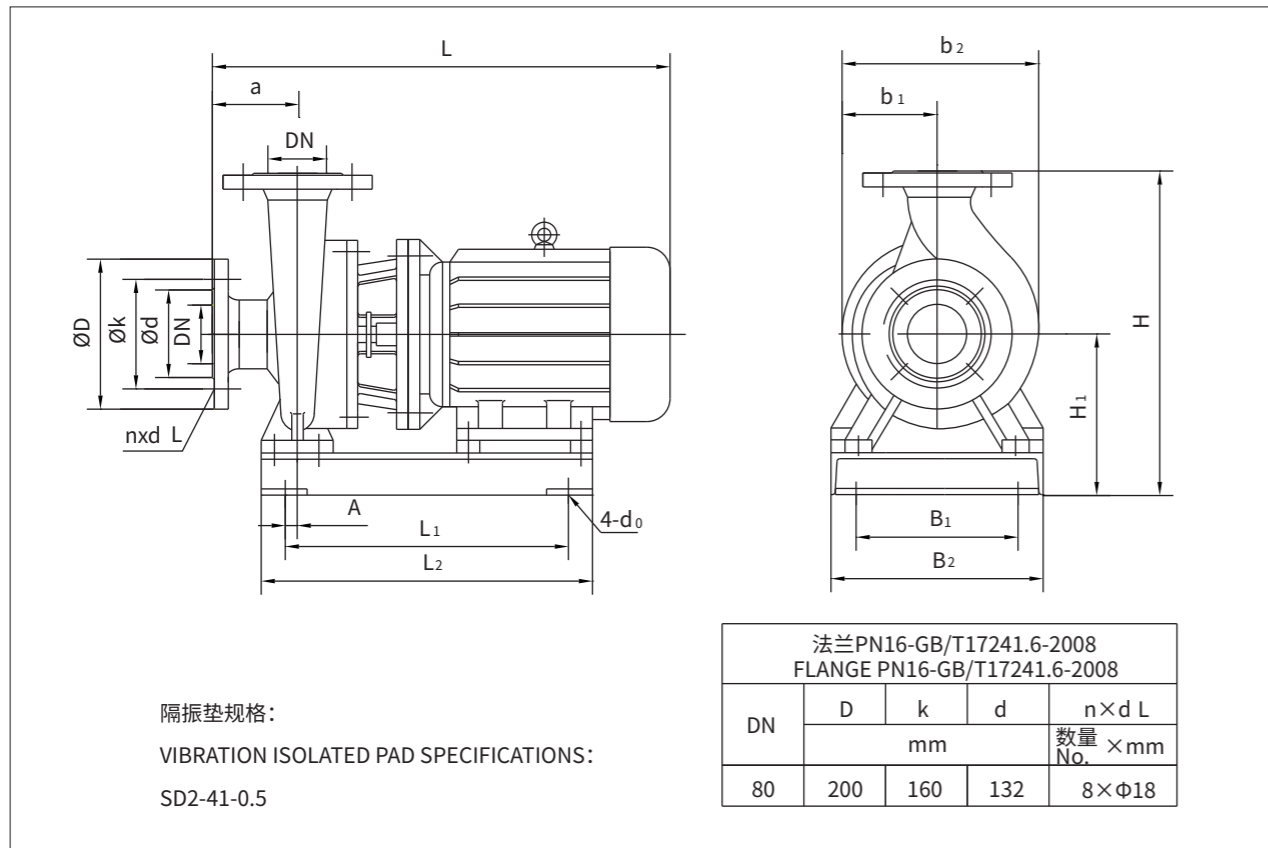

DIMENSION TABLE
KQW尺寸表

型号 TYPE	外形尺寸 Figure dimensions				安装尺寸 Installing dimensions								DN
	L	H	b ₂	b ₁	4-φ ₀	a	L ₁	B ₁	L ₂	B ₂	H ₁	A	
80KQW45-10-2.2/2	570	457	256	125	4-φ12	100	290	160	390	250	247	0	80
80KQW50-12.5-3/2	605	457	256	125	4-φ12	100	300	160	400	250	247	0	80
80KQW45-16-3/2	605	457	256	125	4-φ12	100	300	160	400	250	247	0	80
80KQW50-20-4/2	640	457	256	125	4-φ12	100	310	160	410	250	247	0	80
80KQW40-24-4/2	640	457	256	125	4-φ12	100	310	160	410	250	247	0	80
80KQW47-28-5.5/2	670	461	300	150	4-φ15	100	350	180	450	280	251	0	80
80KQW50-32-7.5/2	670	461	300	150	4-φ15	100	350	180	450	275	251	0	80
80KQW35-34-5.5/2	670	461	300	150	4-φ15	100	350	180	450	280	251	0	80
80KQW44-38-7.5/2	700	527	323	160	4-φ15	125	370	220	470	330	277	12.5	80
80KQW47-44-11/2	842	527	350	175	4-φ15	125	470	220	570	330	277	12.5	80
80KQW50-50-15/2	840	527	350	175	4-φ15	125	470	220	570	320	277	12.5	80

CHARACTERISTIC CURVE
性能曲线

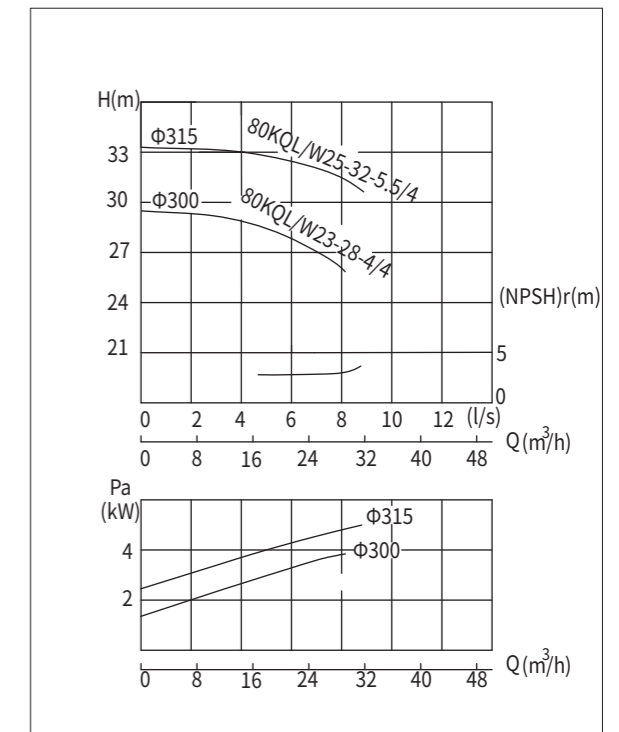
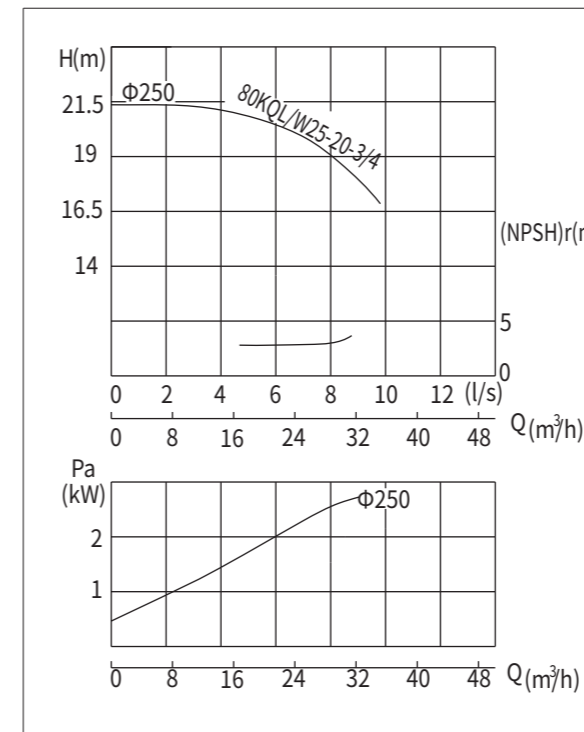
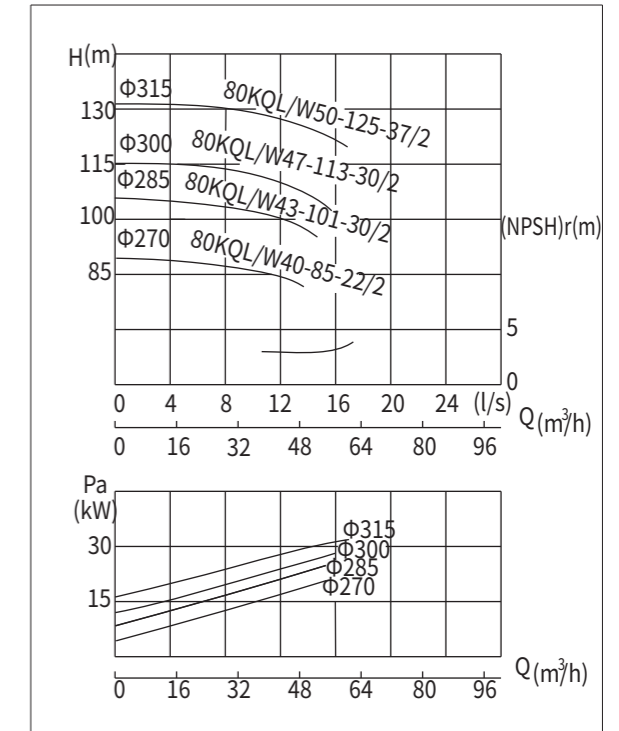
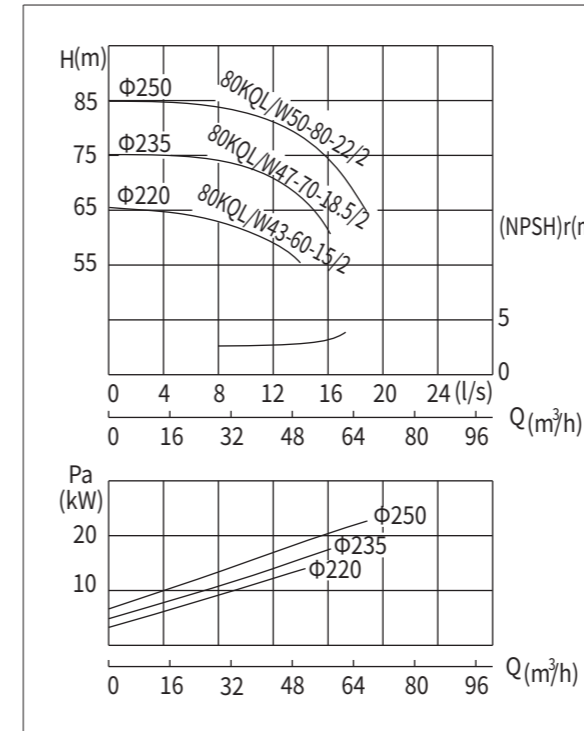

PERFORMANCE DATA
参数表

型号 TYPE	流量 Capacity		扬程 Head (m)	转速 Speed (r/min)	效率 Efficiency (%)	电机 功率 Power (kW)	必需 汽蚀 余量 (NPSH)r (m)	重量 Weight (kg)
	(m ³ /h)	(l/s)						
80KQL/W43-60-15/2	30	8.3	62	2960	61	15	3	186
	43.3	12	60					
	52	14.4	54					
80KQL/W47-70-18.5/2	32.5	9	73	2960	62	18.5	3	205
	46.7	13	70					
	56	15.6	63					
80KQL/W50-80-22/2	35	9.72	83	2960	63	22	3	240
	50	13.9	80					
	60	16.7	72					
80KQL/W40-85-22/2	28	7.78	88	2960	54	22	3	249
	40	11.1	85					
	48	13.3	78					
80KQL/W43-101-30/2	30	8.3	105	2960	55	30	3	420
	43.3	12	101					
	52	14.4	94					
80KQL/W47-113-30/2	32.5	9	117	2960	56	30	3	420
	46.7	13	113					
	56	15.6	106					
80KQL/W50-125-37/2	35	9.72	129	2960	57	37	3	450
	50	13.9	125					
	60	16.7	118					
80KQL/W25-20-3/4	15	4.17	21	1480	59	3	2.8	145
	25	6.94	20					
	30	8.33	18.3					
80KQL/W23-28-4/4	14	3.89	28.3	1480	52	4	2.8	181
	23	6.39	27.9					
	28	7.78	25.3					
80KQL/W25-32-5.5/4	15	4.17	33	1480	52.6	5.5	2.8	188
	25	6.94	32					
	30	8.33	30					

DIMENSION FIGURE
尺寸图

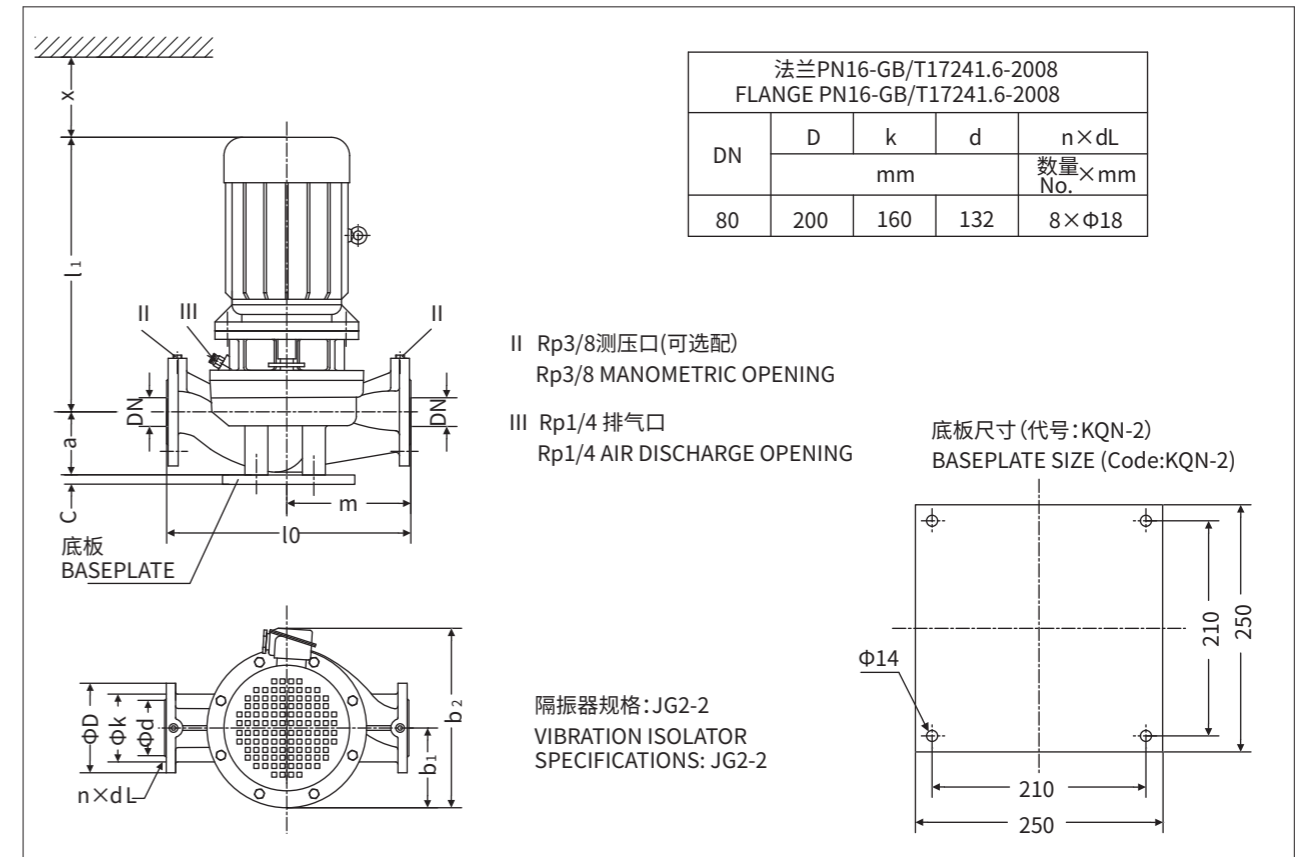

DIMENSION TABLE
KQL尺寸表

型号 TYPE	DN	l ₀	m	a	c	l ₁	b ₁	b ₂	x
80KQL43-60-15/2	80	540	270	155	30	705	225	485	120
80KQL47-70-18.5/2	80	540	270	155	30	735	225	485	120
80KQL50-80-22/2	80	540	270	155	30	775	250	530	120
80KQL25-20-3/4	80	540	270	155	30	521	155	335	120

DIMENSION FIGURE
尺寸图

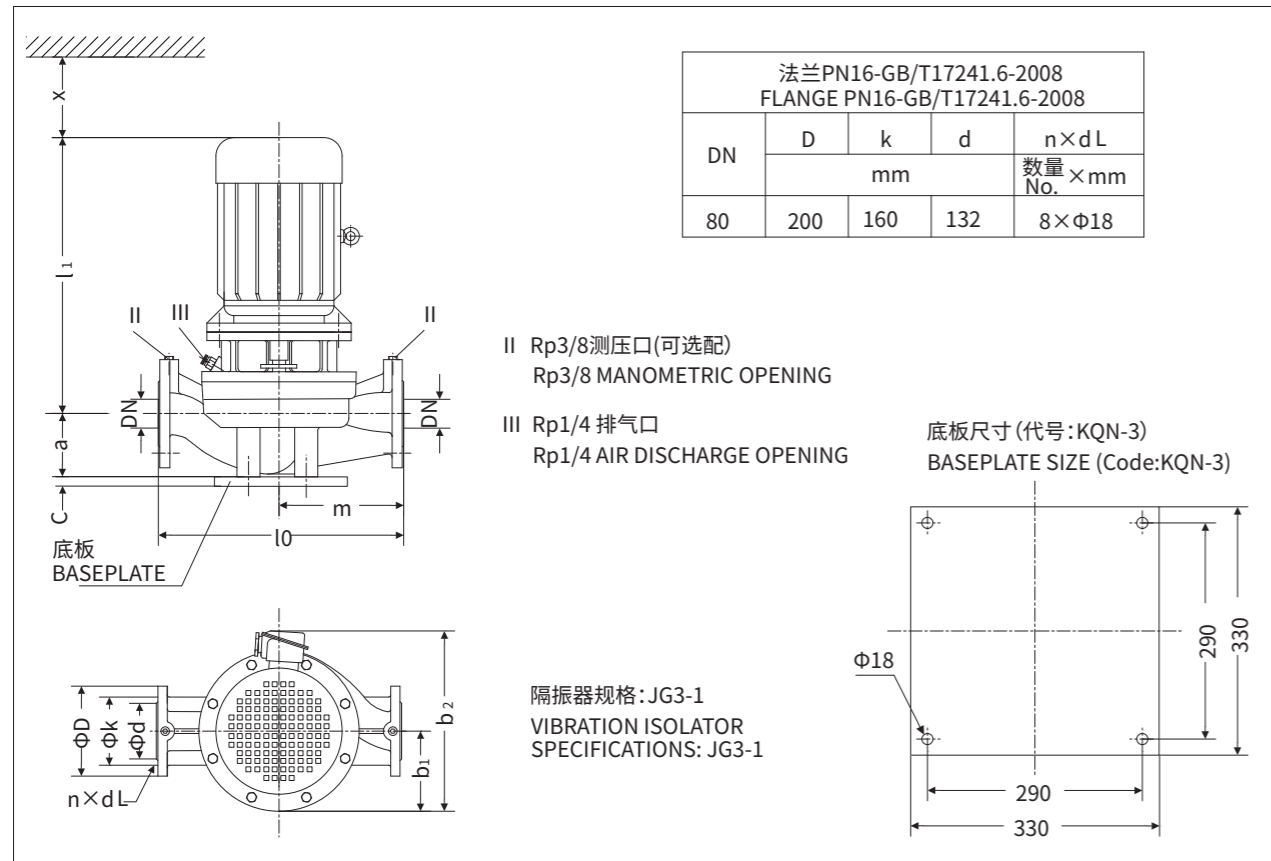

DIMENSION FIGURE
尺寸图

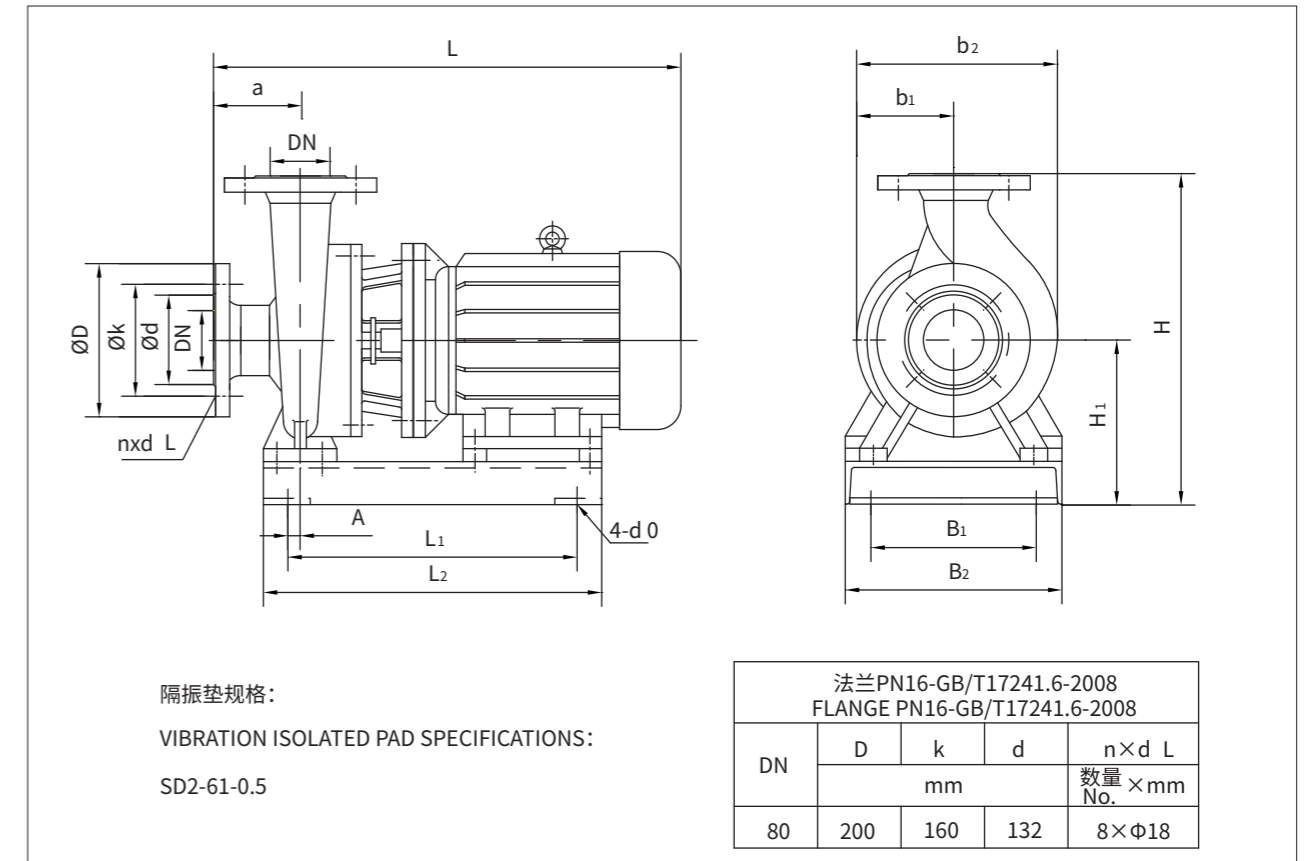

DIMENSION TABLE
KQL尺寸表

型号	DN	l0	m	a	c	l1	b1	b2	x
TYPE		mm							
80KQL40-85-22/2	80	600	290	175	30	790	200	430	120
80KQL43-101-30/2	80	600	290	175	30	840	210	545	120
80KQL47-113-30/2	80	600	290	175	30	840	210	545	120
80KQL50-125-37/2	80	600	290	175	30	840	210	545	120
80KQL23-28-4/4	80	600	290	175	30	570	210	545	120
80KQL25-32-5.5/4	80	600	290	175	30	590	210	545	120

DIMENSION TABLE
KQW尺寸表

型号	外形尺寸				安装尺寸								DN
	Figure dimensions				Installing dimensions								
TYPE	L	H	b2	b1	4-φ0	a	L1	B1	L2	B2	H1	A	
80KQW43-60-15/2	840	527	350	175	4-φ15	125	470	220	570	330	277	12.5	80
80KQW47-70-18.5/2	870	527	350	175	4-φ15	125	510	220	610	330	277	12.5	80
80KQW50-80-22/2	910	535	380	190	4-φ15	125	515	260	615	370	285	12.5	80
80KQW40-85-22/2	925	620	393	190	4-φ15	125	520	260	620	360	330	12.5	80
80KQW43-101-30/2	975	619	420	210	4-φ15	125	610	300	710	400	329	12.5	80
80KQW47-113-30/2	975	619	420	210	4-φ15	125	610	300	710	400	329	12.5	80
80KQW50-125-37/2	975	619	420	210	4-φ15	125	610	300	710	400	329	12.5	80
80KQW25-20-3/4	645	527	323	160	4-φ15	125	315	220	425	320	277	10	80
80KQW23-28-4/4	675	620	392	189	4-φ15	125	315	280	440	360	330	10	80
80KQW25-32-5.5/4	705	620	392	189	4-φ15	125	395	280	470	360	330	20	80

CHARACTERISTIC CURVE
性能曲线

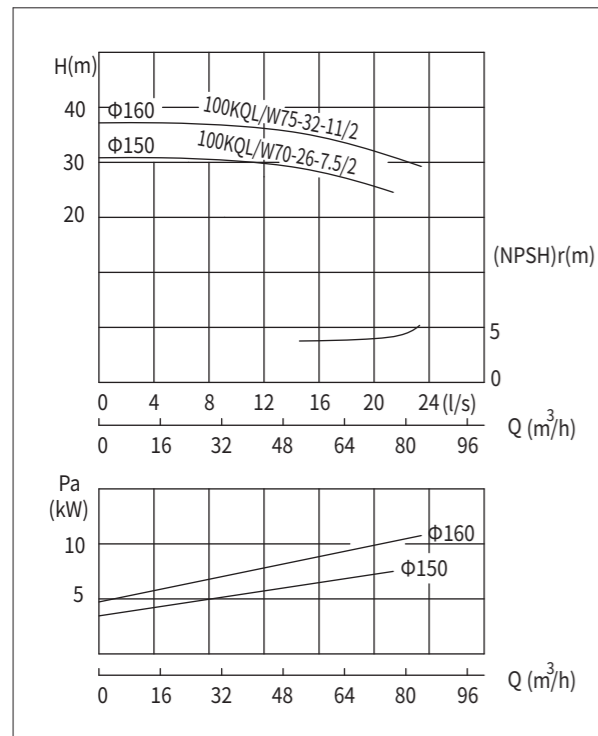
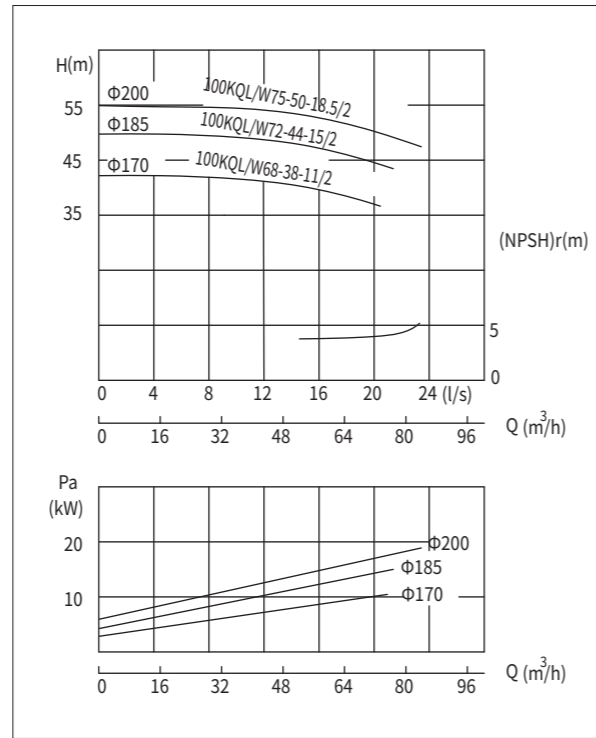
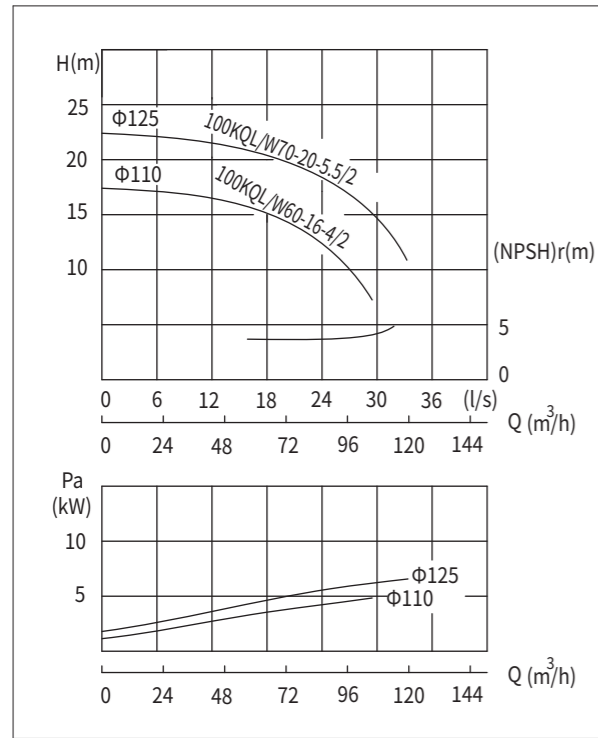

PERFORMANCE DATA
参数表

型号 TYPE	流量 Capacity		扬程 Head (m)	转速 Speed (r/min)	效率 Efficiency (%)	电机 功率 Power (kW)	必需 汽蚀 余量 (NPSH) _r (m)	重量 Weight (kg)
	(m ³ /h)	(l/s)						
100KQL/W60-16-4/2	42	11.7	17.5	2960	77	4	4.5	91
	60	16.7	16					
	66	18.3	14.8					
100KQL/W70-20-5.5/2	49	13.6	22	2960	78	5.5	4.5	115
	70	19.4	20					
	77	21.4	18.5					
100KQL/W70-26-7.5/2	49	13.6	27.3	2960	77	7.5	4.5	132
	70	19.4	26					
	77	21.4	24.3					
100KQL/W75-32-11/2	52.5	14.6	34.5	2960	78	11	4.5	178
	75	20.8	32					
	82.5	22.9	29.3					
100KQL/W68-38-11/2	47.6	13.2	41	2960	74	11	4	179
	68	18.9	38					
	74.8	20.8	34.2					
100KQL/W72-44-15/2	50.4	14.0	48.5	2960	75	15	4	189
	72	20.0	44					
	79.2	22.0	41					
100KQL/W75-50-18.5/2	52.5	14.6	53	2960	76	18.5	4	218
	75	20.8	50					
	82.5	22.9	46					

DIMENSION FIGURE
尺寸图

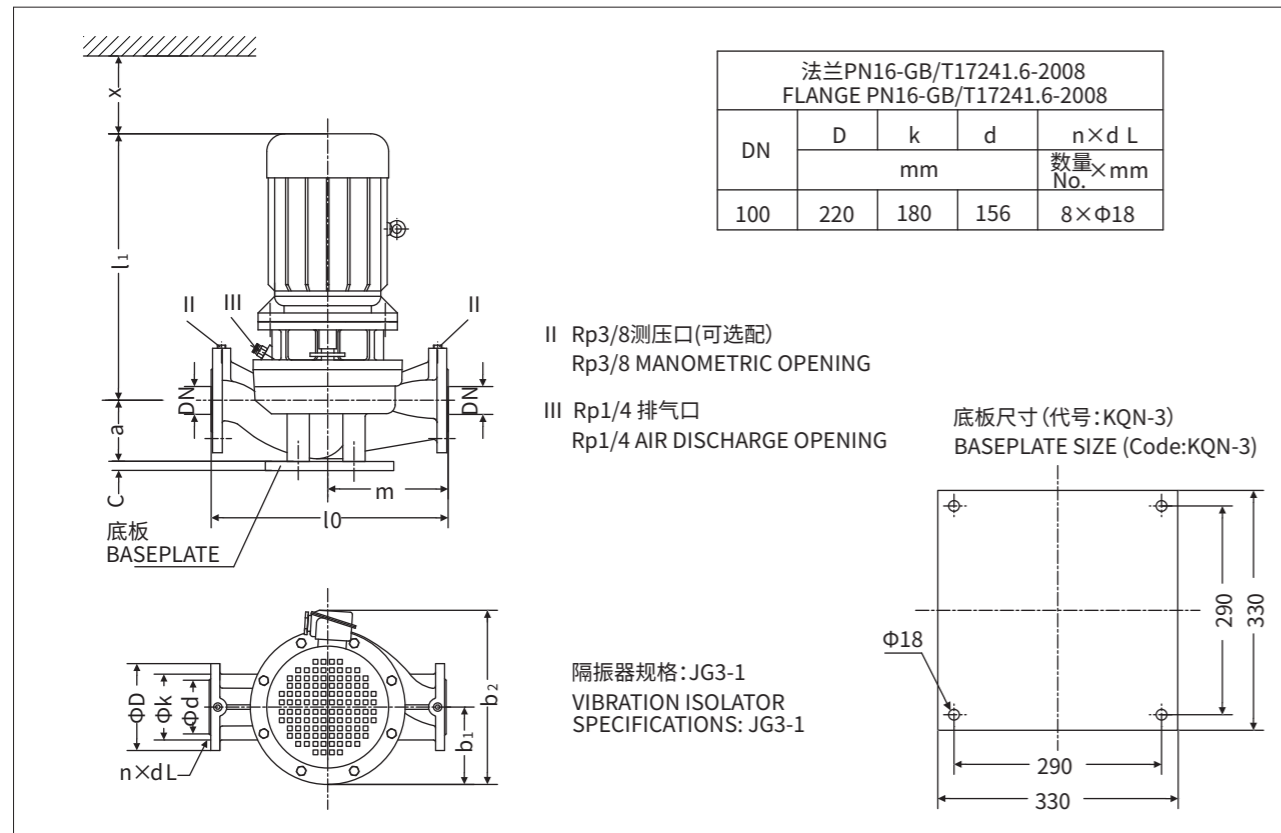

DIMENSION FIGURE
尺寸图

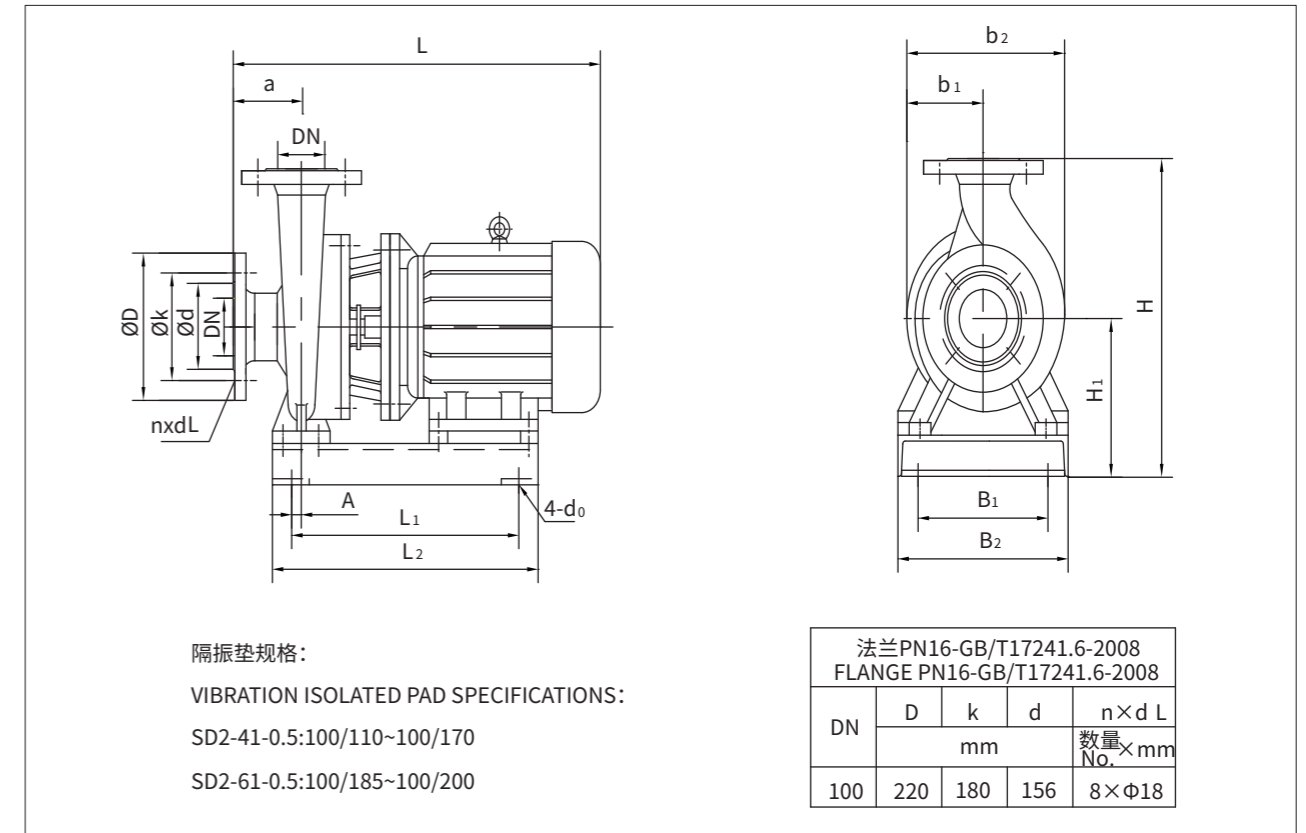

DIMENSION TABLE
KQL尺寸表

型号 TYPE	DN	l0	m	a	c	l1	b1	b2	x
mm									
100KQL60-16-4/2	100	580	280	180	30	560	125	315	130
100KQL70-20-5.5/2	100	580	280	180	30	580	185	400	130
100KQL70-26-7.5/2	100	580	280	180	30	580	185	400	130
100KQL75-32-11/2	100	580	280	180	30	710	225	485	130
100KQL68-38-11/2	100	630	310	180	30	720	225	485	130
100KQL72-44-15/2	100	630	310	180	30	720	225	485	130
100KQL75-50-18.5/2	100	630	310	180	30	750	225	485	130

DIMENSION TABLE
KQW尺寸表

型号 TYPE	外形尺寸 Figure dimensions				安装尺寸 Installing dimensions							DN	
	L	H	b2	b1	4-d0	a	L1	B1	L2	B2	H1		A
100KQW60-16-4/2	670	516	302	150	4-Φ15	100	345	180	445	280	251	12.5	100
100KQW70-20-5.5/2	690	516	302	150	4-Φ15	100	375	180	475	280	251	12.5	100
100KQW70-26-7.5/2	690	516	302	150	4-Φ15	100	375	180	475	280	251	12.5	100
100KQW75-32-11/2	820	517	350	175	4-Φ15	100	475	220	575	320	252	12.5	100
100KQW68-38-11/2	845	595	368	180	4-Φ15	125	475	260	575	360	305	12.5	100
100KQW72-44-15/2	845	595	368	180	4-Φ15	125	475	260	575	360	305	12.5	100
100KQW75-50-18.5/2	875	595	368	180	4-Φ15	125	515	260	620	360	305	12.5	100

CHARACTERISTIC CURVE
性能曲线

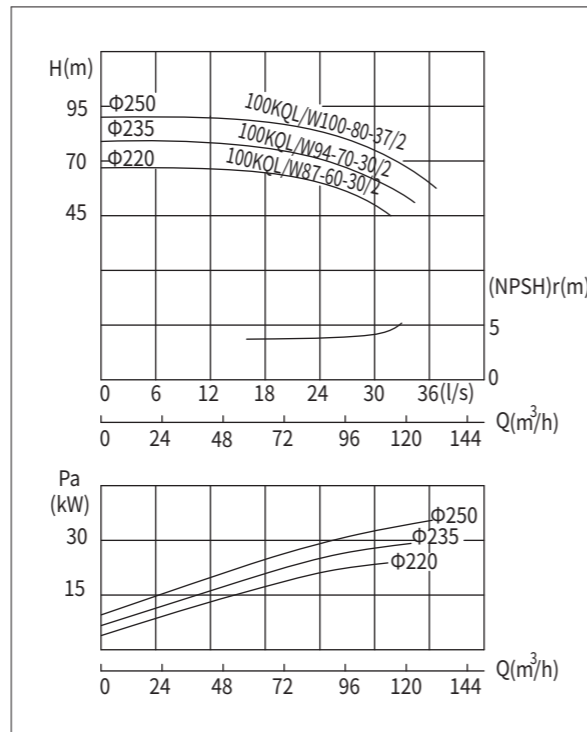
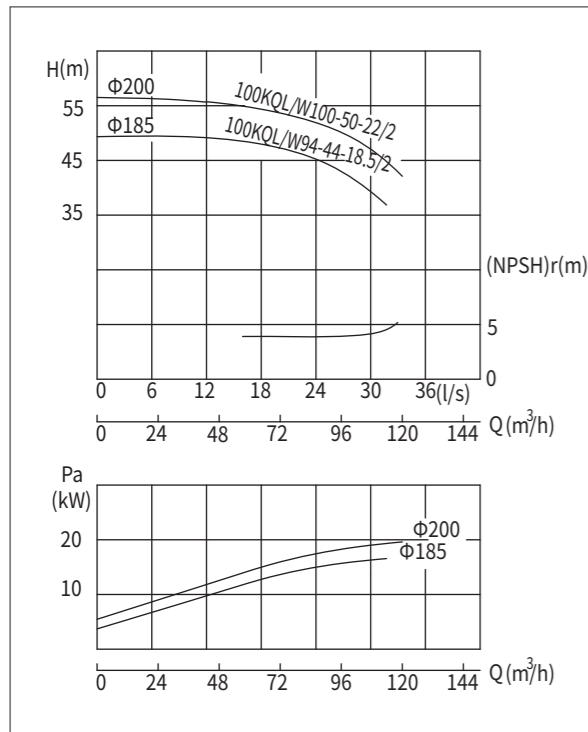
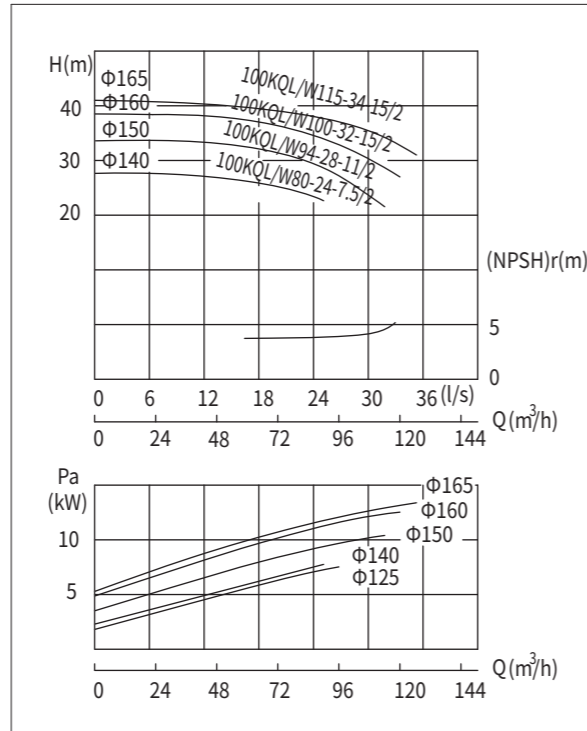
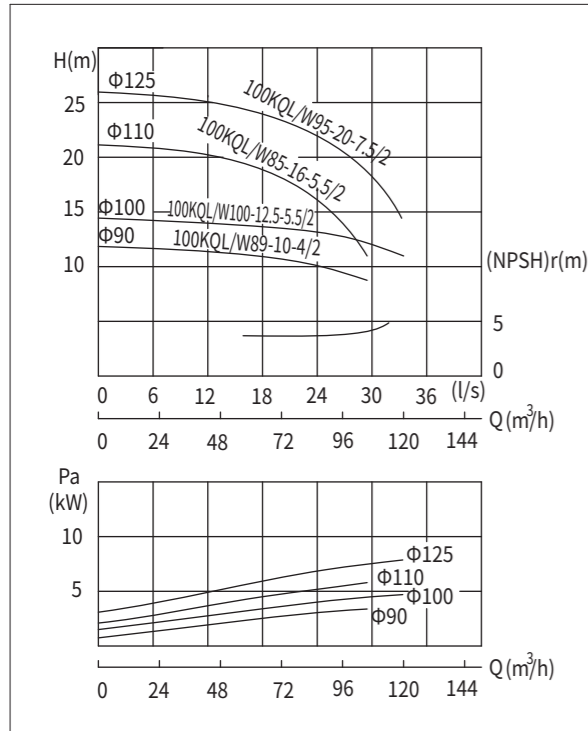

PERFORMANCE DATA
参数表

型号 TYPE	流量 Capacity		扬程 Head (m)	转速 Speed (r/min)	效率 Efficiency (%)	电机 功率 Power (kW)	必需 汽蚀 余量 (NPSH)r (m)	重量 Weight (kg)
	(m³/h)	(l/s)						
100KQL/W89-10-4/2	62.6	17.4	12	2960	77	4	4.5	94
	89	24.7	10					
	107	29.7	8.8					
100KQL/W100-12.5-5.5/2	70	19.4	13.6	2960	78	5.5	4.5	113
	100	27.8	12.5					
	120	33.3	8					
100KQL/W85-16-5.5/2	59.5	16.5	16.8	2960	79	5.5	4.5	115
	85	23.6	16					
	93.5	26.0	14.4					
100KQL/W95-20-7.5/2	66.5	18.5	22.8	2960	80	7.5	4.5	132
	95	26.4	20					
	104.5	29.0	18.5					
100KQL/W80-24-7.5/2	56	15.6	25.2	2960	79	7.5	4.5	135
	80	22.2	24					
	88	24.4	22.4					
100KQL/W94-28-11/2	65.4	18.2	32	2960	78	11	4.5	190
	93.5	26.0	28					
	112	31.1	23					
100KQL/W100-32-15/2	70	19.4	35	2960	79	15	4.5	195
	100	27.8	32					
	120	33.3	27					
100KQL/W115-34-15/2	80.5	22.4	38.5	2960	79	15	4.5	190
	115	31.9	34					
	126.5	35.1	32					
100KQL/W94-44-18.5/2	65.4	18.2	47.5	2960	78	18.5	4	218
	93.5	26.0	44					
	112	31.1	37					
100KQL/W100-50-22/2	70	19.4	54	2960	79	22	4	250
	100	27.8	50					
	120	33.3	42					
100KQL/W87-60-30/2	61	16.9	65	2960	73	30	4	346
	87	24.2	60					
	104	28.9	50					
100KQL/W94-70-30/2	65.4	18.2	76	2960	74	30	4	347
	93.5	26.0	70					
	112	31.1	59					
100KQL/W100-80-37/2	70	19.4	87	2960	75	37	4	370
	100	27.8	80					
	120	33.3	68					

DIMENSION FIGURE
尺寸图

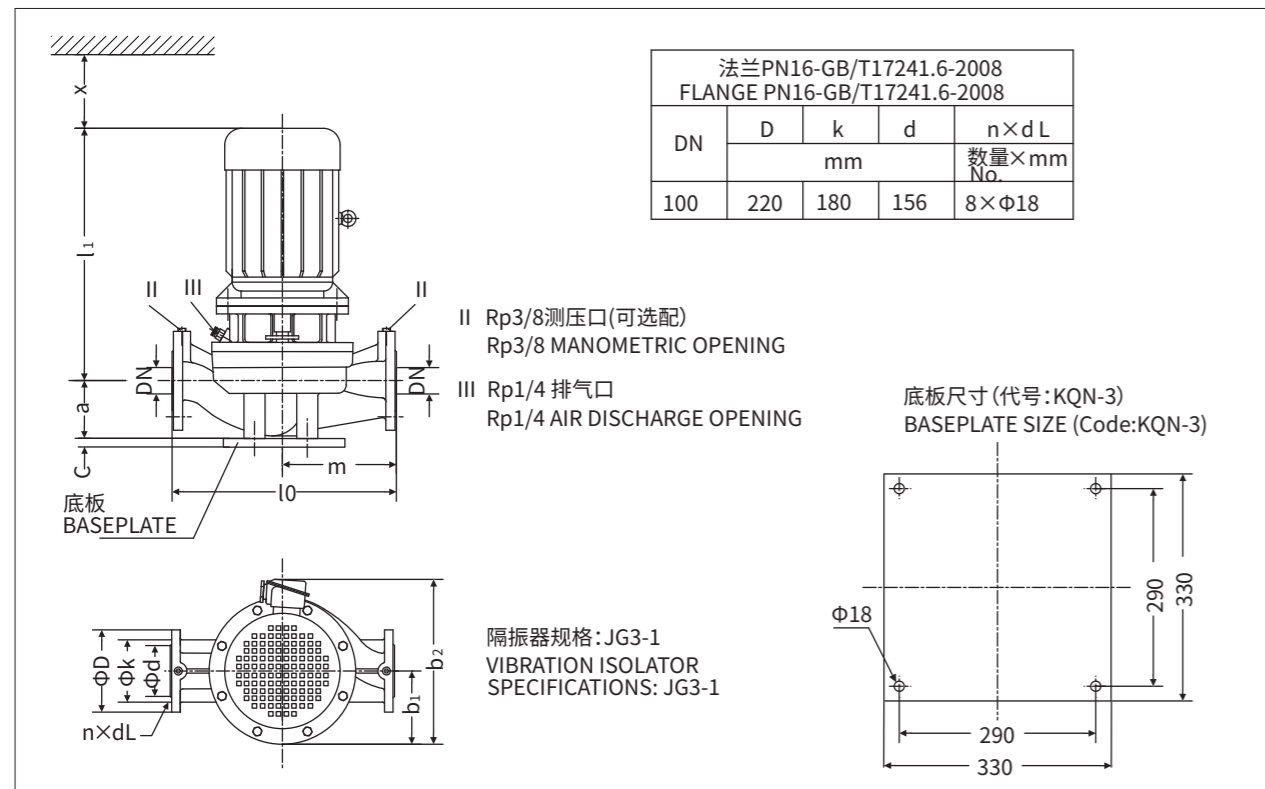

DIMENSION TABLE
KQL尺寸表

型号 TYPE	DN	外形尺寸 Figure dimensions							
		l ₀	m	a	c	l ₁	b ₁	b ₂	x
100KQL89-10-4/2	100	580	280	180	30	560	125	360	130
100KQL100-12.5-5.5/2	100	580	280	180	30	580	185	400	130
100KQL85-16-5.5/2	100	580	280	180	30	580	185	400	130
100KQL95-20-7.5/2	100	580	280	180	30	580	185	400	130
100KQL80-24-7.5/2	100	580	280	180	30	580	185	400	130
100KQL94-28-11/2	100	580	280	180	30	710	225	485	130
100KQL100-32-15/2	100	580	280	180	30	710	225	485	130
100KQL115-34-15/2	100	580	280	180	30	710	225	485	130
100KQL94-44-18.5/2	100	630	310	180	30	735	225	485	130
100KQL100-50-22/2	100	630	310	180	30	780	250	530	130
100KQL87-60-30/2	100	630	310	180	30	840	270	575	130
100KQL94-70-30/2	100	630	310	180	30	840	270	575	130
100KQL100-80-37/2	100	630	310	180	30	840	270	575	130

DIMENSION FIGURE
尺寸图

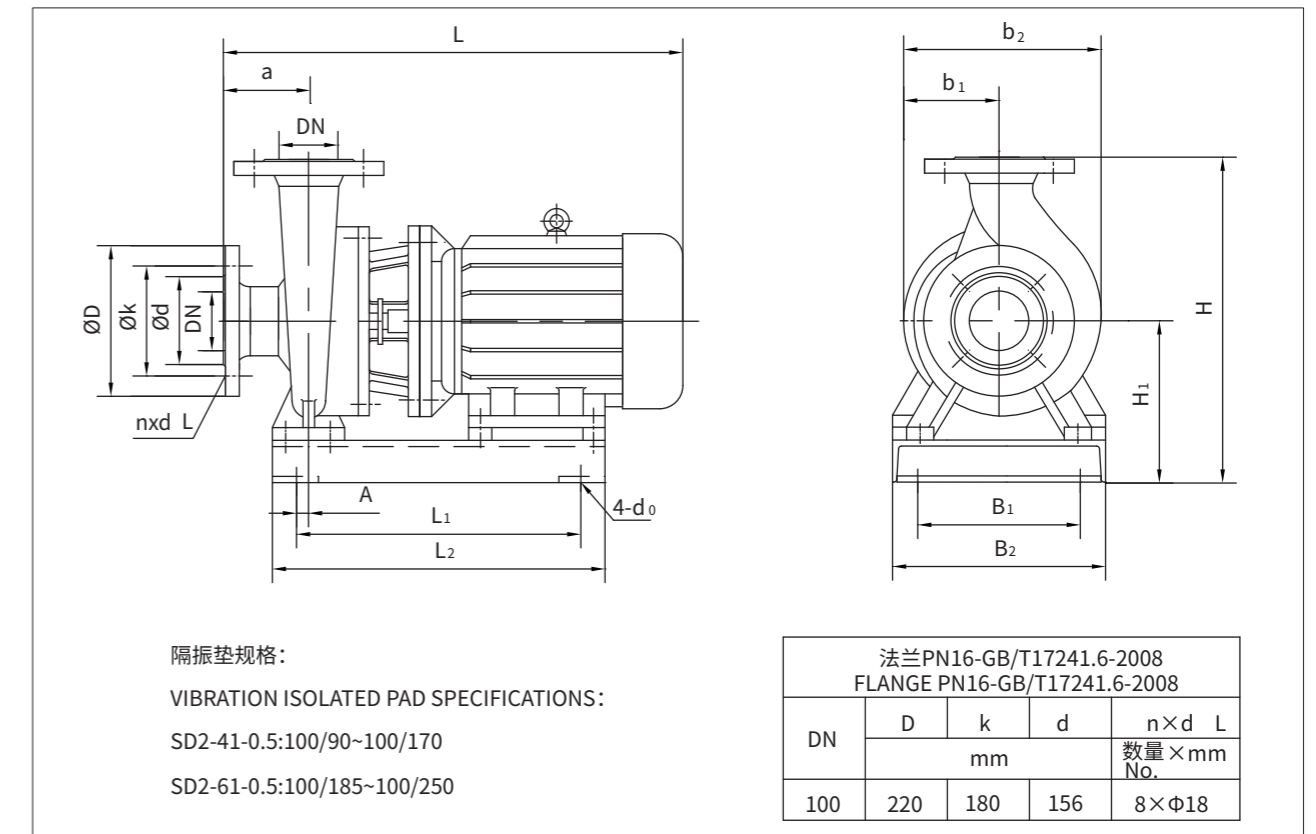

DIMENSION TABLE
KQW尺寸表

型号 TYPE	外形尺寸 Figure dimensions				安装尺寸 Installing dimensions								DN
	L	H	b ₂	b ₁	4-d ₀	a	L ₁	B ₁	L ₂	B ₂	H ₁	A	
100KQW89-10-4/2	650	516	302	150	4-Φ15	100	345	180	445	280	251	12.5	100
100KQW100-12.5-5.5/2	690	516	302	150	4-Φ15	100	375	180	475	280	251	12.5	100
100KQW85-16-5.5/2	690	516	302	150	4-Φ15	100	375	180	475	280	251	12.5	100
100KQW95-20-7.5/2	690	516	302	150	4-Φ15	100	375	180	475	280	251	12.5	100
100KQW80-24-7.5/2	690	516	302	150	4-Φ15	100	375	180	475	280	251	12.5	100
100KQW94-28-11/2	820	517	350	175	4-Φ15	100	475	220	575	320	252	12.5	100
100KQW100-32-15/2	820	517	350	175	4-Φ15	100	475	220	575	320	252	12.5	100
100KQW115-34-15/2	820	517	350	175	4-Φ15	100	475	220	575	320	252	12.5	100
100KQW94-44-18.5/2	875	595	368	180	4-Φ15	125	515	260	615	360	305	12.5	100
100KQW100-50-22/2	915	595	380	190	4-Φ15	125	520	260	620	360	305	12.5	100
100KQW87-60-30/2	975	594	420	210	4-Φ15	125	610	300	710	400	304	12.5	100
100KQW94-70-30/2	975	594	420	210	4-Φ15	125	610	300	710	400	304	12.5	100
100KQW100-80-37/2	975	594	420	210	4-Φ15	125	610	300	710	400	304	12.5	100

CHARACTERISTIC CURVE
性能曲线

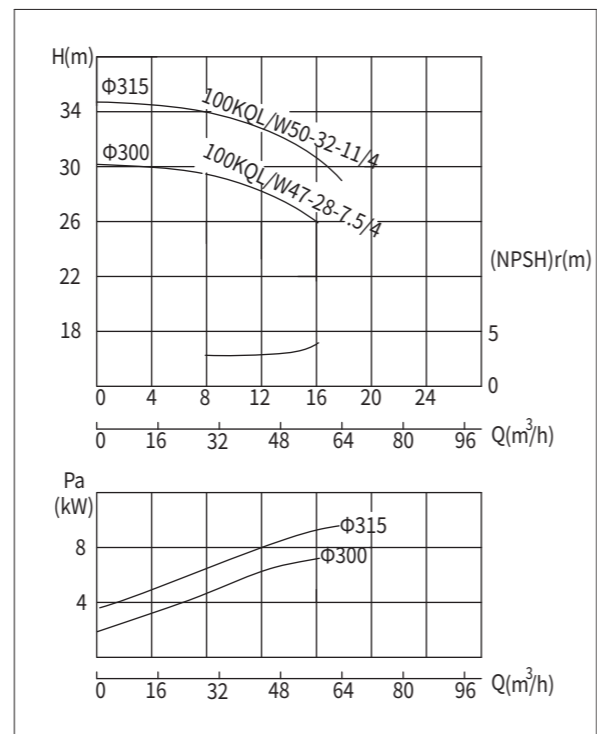
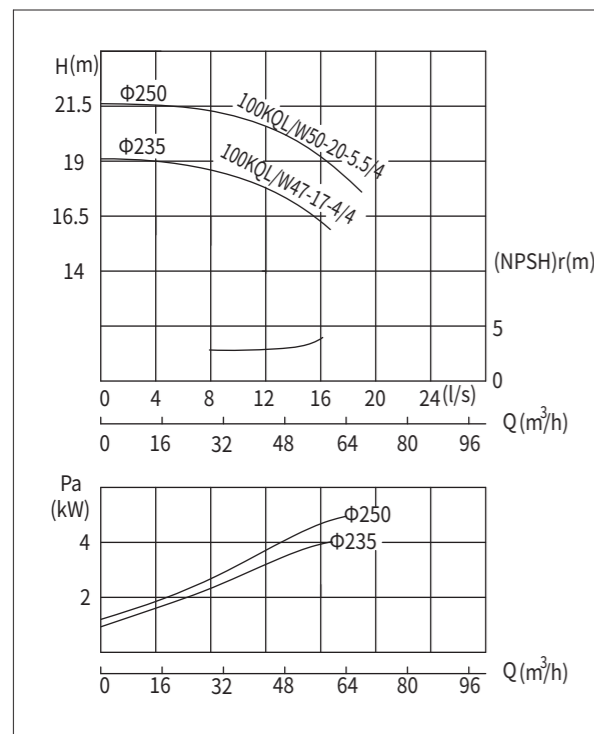
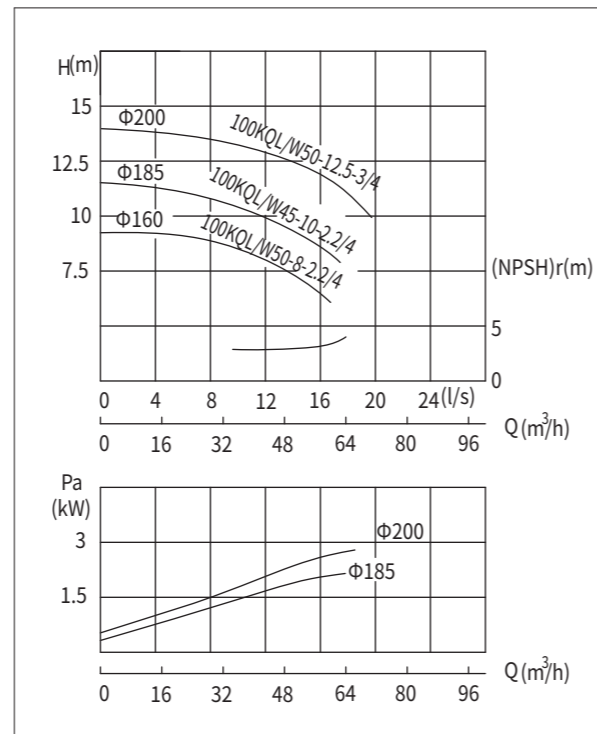
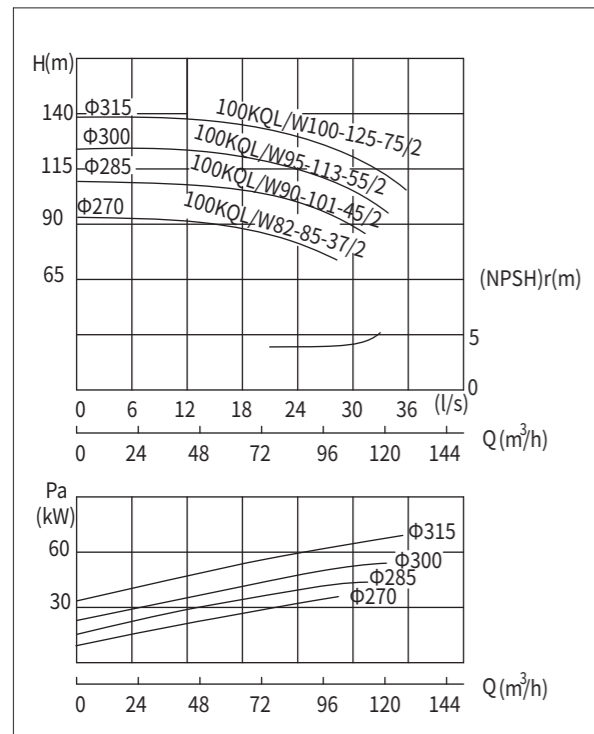

PERFORMANCE DATA
参数表

型号 TYPE	流量 Capacity		扬程 Head (m)	转速 Speed (r/min)	效率 Efficiency (%)	电机 功率 Power (kW)	必需 汽蚀 余量 (NPSH)r (m)	重量 Weight (kg)
	(m³/h)	(l/s)						
100KQL/W82-85-37/2	58	16.1	88	2960	66	37	4	361
	82	22.8	85					
	98.5	27.3	78					
100KQL/W90-101-45/2	63	17.5	105	2960	67	45	4	475
	90	25	101					
	108	30	94					
100KQL/W95-113-55/2	66	18.3	117	2960	68	55	4	618
	95	26.4	113					
	114	31.7	106					
100KQL/W100-125-75/2	70	19.4	129	2960	69	75	4	760
	100	27.8	125					
	120	33.3	118					
100KQL/W50-8-2.2/4	30	8.33	9.2	1480	77	2.2	3	120
	50	13.89	8					
	60	16.67	6.8					
100KQL/W45-10-2.2/4	26.8	7.44	10.7	1480	70	2.2	3	80
	44.6	12.4	9.9					
	53.5	14.9	9.4					
100KQL/W50-12.5-3/4	30	8.33	13.5	1480	71	3	3	93
	50	13.89	12.5					
	60	16.67	11.8					
100KQL/W47-17-4/4	28	7.78	18.6	1480	70	4	3	110
	46.7	12.97	17.4					
	56	15.56	16.6					
100KQL/W50-20-5.5/4	30	8.33	21.3	1480	71	5.5	3	139
	50	13.89	20					
	60	16.67	19					
100KQL/W47-28-7.5/4	28	7.78	29.6	1480	64	7.5	3	220
	46.7	12.97	27.9					
	56	15.56	26.1					
100KQL/W50-32-11/4	30	8.33	34	1480	65	11	3	236
	50	13.89	32					
	60	16.67	29					

DIMENSION FIGURE
尺寸图

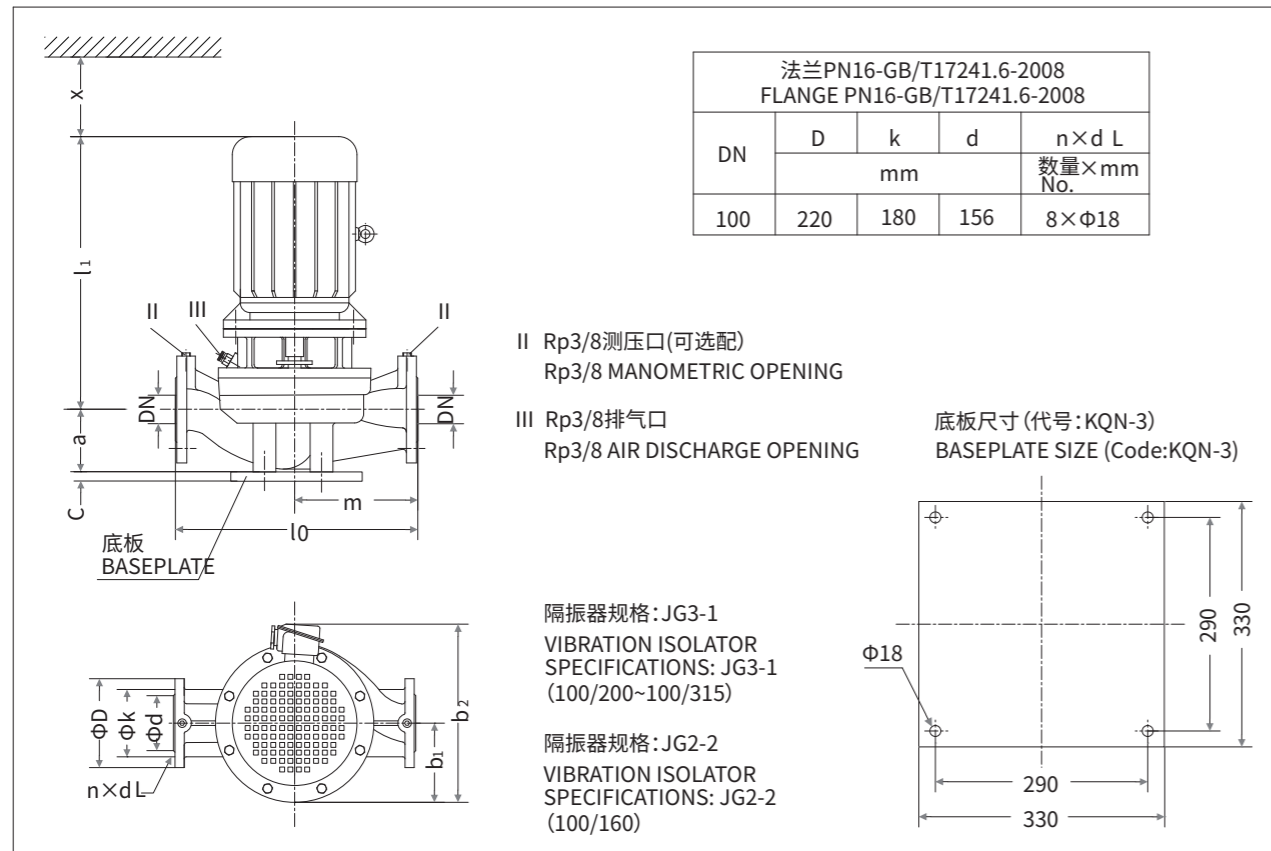

DIMENSION TABLE
KQL尺寸表

型号 TYPE	DN	l ₀	m	a	c	l ₁	b ₁	b ₂	x
		mm							
100KQL82-85-37/2	100	640	315	175	30	860	210	525	130
100KQL90-101-45/2	100	640	315	175	30	895	240	585	130
100KQL95-113-55/2	100	640	315	175	30	955	275	660	130
100KQL100-125-75/2	100	640	315	175	30	1035	295	705	130
100KQL50-8-2.2/4	100	580	280	180	30	525	130	310	130
100KQL45-10-2.2/4	100	630	310	180	30	535	170	350	130
100KQL50-12.5-3/4	100	630	310	180	30	535	170	360	130
100KQL47-17-4/4	100	630	310	180	30	570	170	360	130
100KQL50-20-5.5/4	100	630	310	180	30	590	170	380	130
100KQL47-28-7.5/4	100	640	315	175	30	659	205	415	130
100KQL50-32-11/4	100	640	315	175	30	739	205	470	130

DIMENSION FIGURE
尺寸图

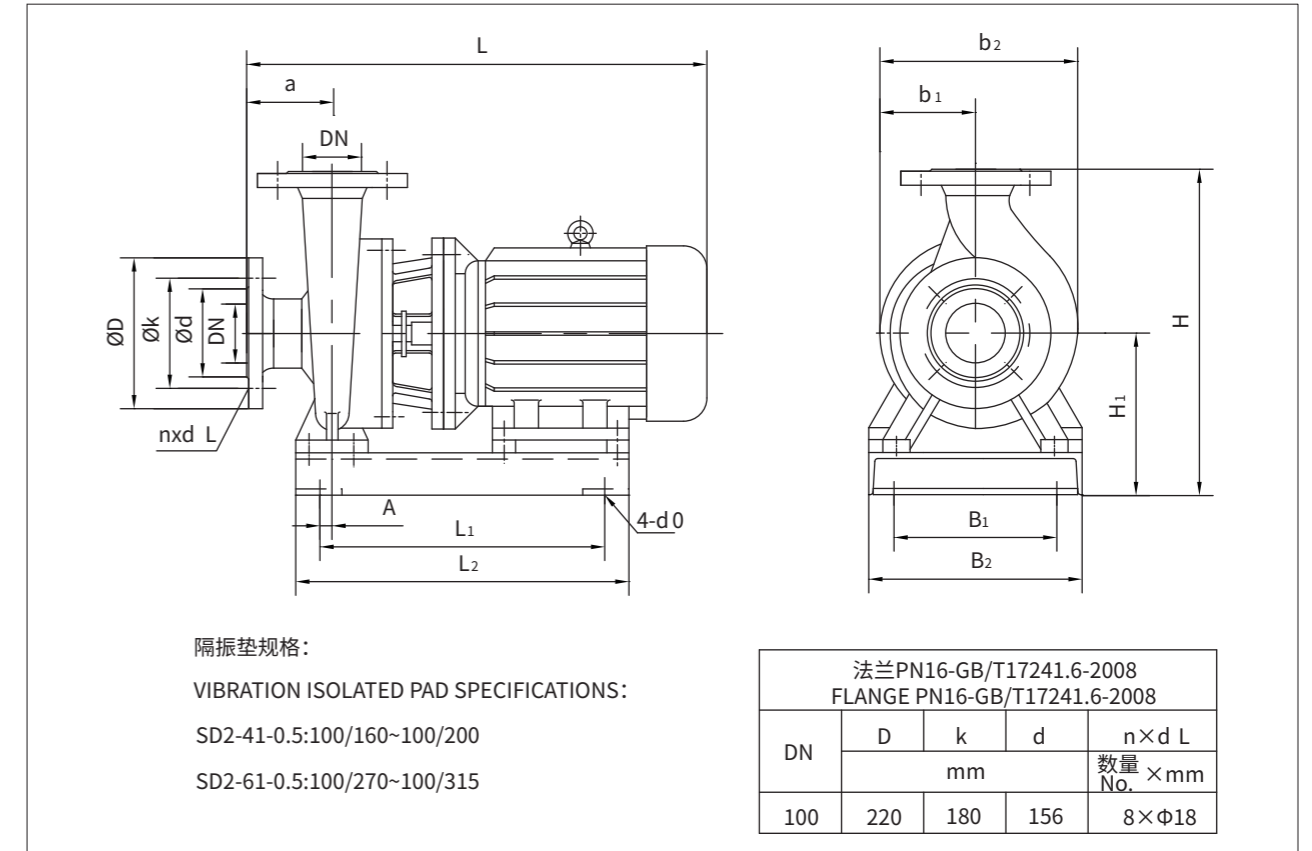

DIMENSION TABLE
KQW尺寸表

型号 TYPE	外形尺寸 Figure dimensions				安装尺寸 Installing dimensions							DN	
	L	H	b ₂	b ₁	4-φd	a	L ₁	B ₁	L ₂	B ₂	H ₁		A
100KQW82-85-37/2	985	644	420	210	4-φ15	125	635	300	735	400	329	30	100
100KQW90-101-45/2	1020	634	470	235	4-φ20	125	665	310	765	440	319	30	100
100KQW95-113-55/2	1080	692	550	275	4-φ20	125	730	370	830	500	377	30	100
100KQW100-125-75/2	1150	696	580	290	4-φ20	125	800	430	900	560	381	30	100
100KQW50-8-2.2/4	615	516	292	140	4-φ15	100	315	180	430	280	251	10	100
100KQW45-10-2.2/4	640	595	355	167	4-φ15	125	315	280	430	360	305	10	100
100KQW50-12.5-3/4	640	595	355	167	4-φ15	125	315	280	430	360	305	10	100
100KQW47-17-4/4	675	595	355	167	4-φ15	125	315	280	440	360	305	10	100
100KQW50-20-5.5/4	705	595	355	167	4-φ15	125	355	280	470	360	305	20	100
100KQW47-28-7.5/4	765	649	397	189	4-φ15	125	400	315	535	400	334	20	100
100KQW50-32-11/4	855	649	397	189	4-φ15	125	450	315	600	400	334	30	100

CHARACTERISTIC CURVE
性能曲线

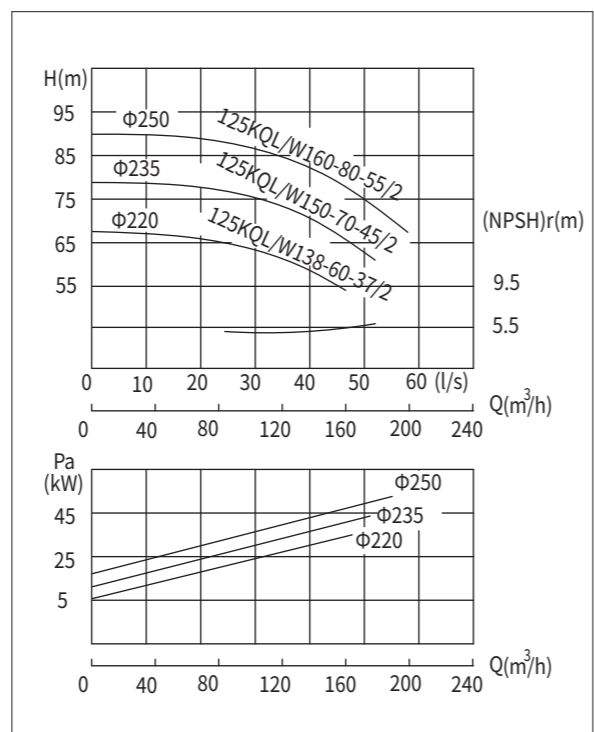
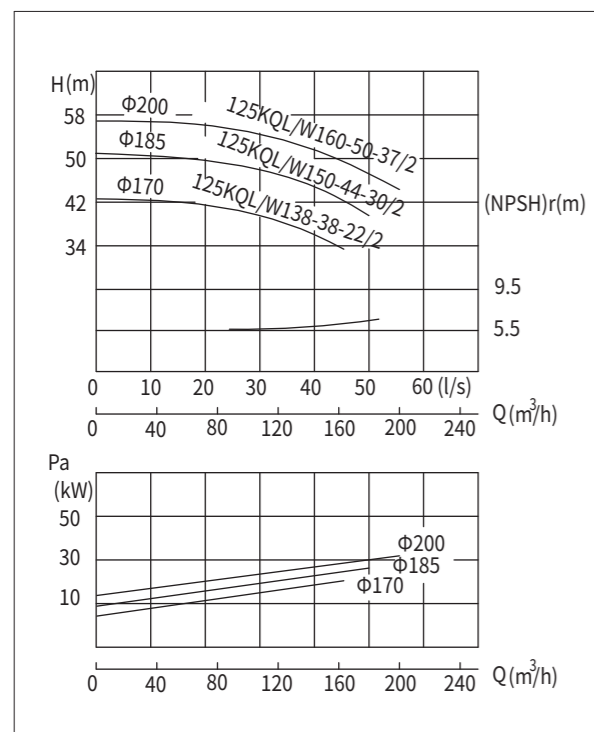
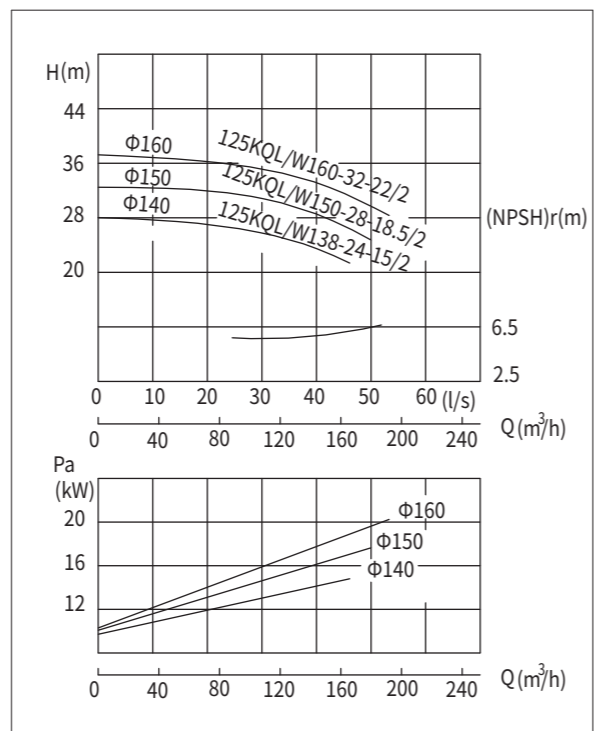
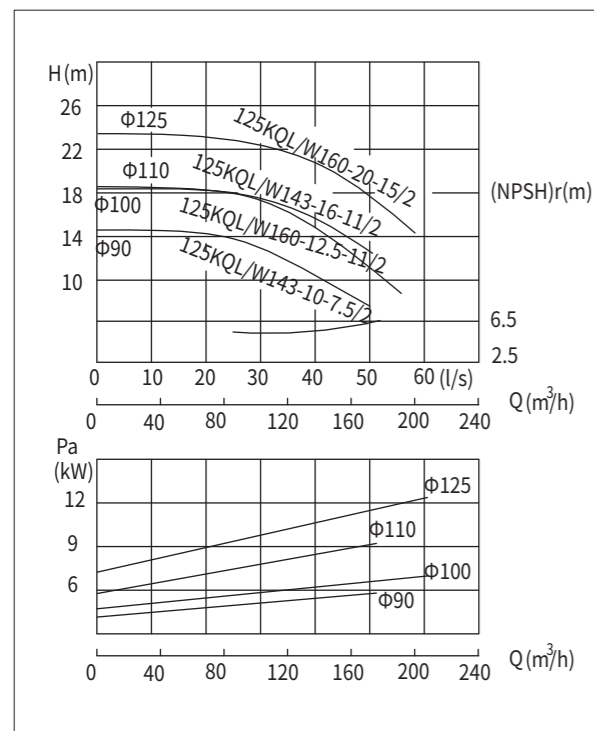

PERFORMANCE DATA
参数表

型号 TYPE	流量 Capacity		扬程 Head (m)	转速 Speed (r/min)	效率 Efficiency (%)	电机 功率 Power (kW)	必需 汽蚀 余量 (NPSH)r (m)	重量 Weight (kg)
	(m³/h)	(l/s)						
125KQL/W143-10-7.5/2	86	23.9	14	2960	74	7.5	5.5	170
	143	39.7	10					
	172	47.8	7					
125KQL/W160-12.5-11/2	96	26.7	18	2960	75	11	5.5	184
	160	44.4	12.5					
	192	53.3	8					
125KQL/W143-16-11/2	86	23.9	19.2	2960	79	11	5.5	185
	143	39.7	16					
	172	47.8	11.5					
125KQL/W160-20-15/2	96	26.7	25	2960	81	15	5.5	240
	160	44.4	20					
	192	53.3	17					
125KQL/W138-24-15/2	83	21.7	26	2960	80	15	5.5	241
	138	38.3	24					
	166	46.1	21					
125KQL/W150-28-18.5/2	90	25	31.5	2960	81	18.5	5.5	217
	150	41.7	28					
	180	50	24.5					
125KQL/W160-32-22/2	96	26.7	36	2960	82	22	5.5	258
	160	44.4	32					
	192	53.3	28					
125KQL/W138-38-22/2	83	21.7	41.3	2960	80	22	5.5	273
	138	38.3	37.5					
	166	46.1	34.5					
125KQL/W150-44-30/2	90	25	48.4	2960	81	30	5.5	366
	150	41.7	44					
	180	50	40.5					
125KQL/W160-50-37/2	96	26.7	55	2960	82	37	5.5	397
	160	44.4	50					
	192	53.3	46					
125KQL/W138-60-37/2	83	21.7	66	2960	78	37	5	504
	138	38.3	60					
	166	46.1	55					
125KQL/W150-70-45/2	90	25	76	2960	79	45	5	555
	150	41.7	70					
	180	50	64					
125KQL/W160-80-55/2	96	26.7	87	2960	80	55	5	636
	160	44.4	80					
	192	53.3	73					

DIMENSION FIGURE
尺寸图

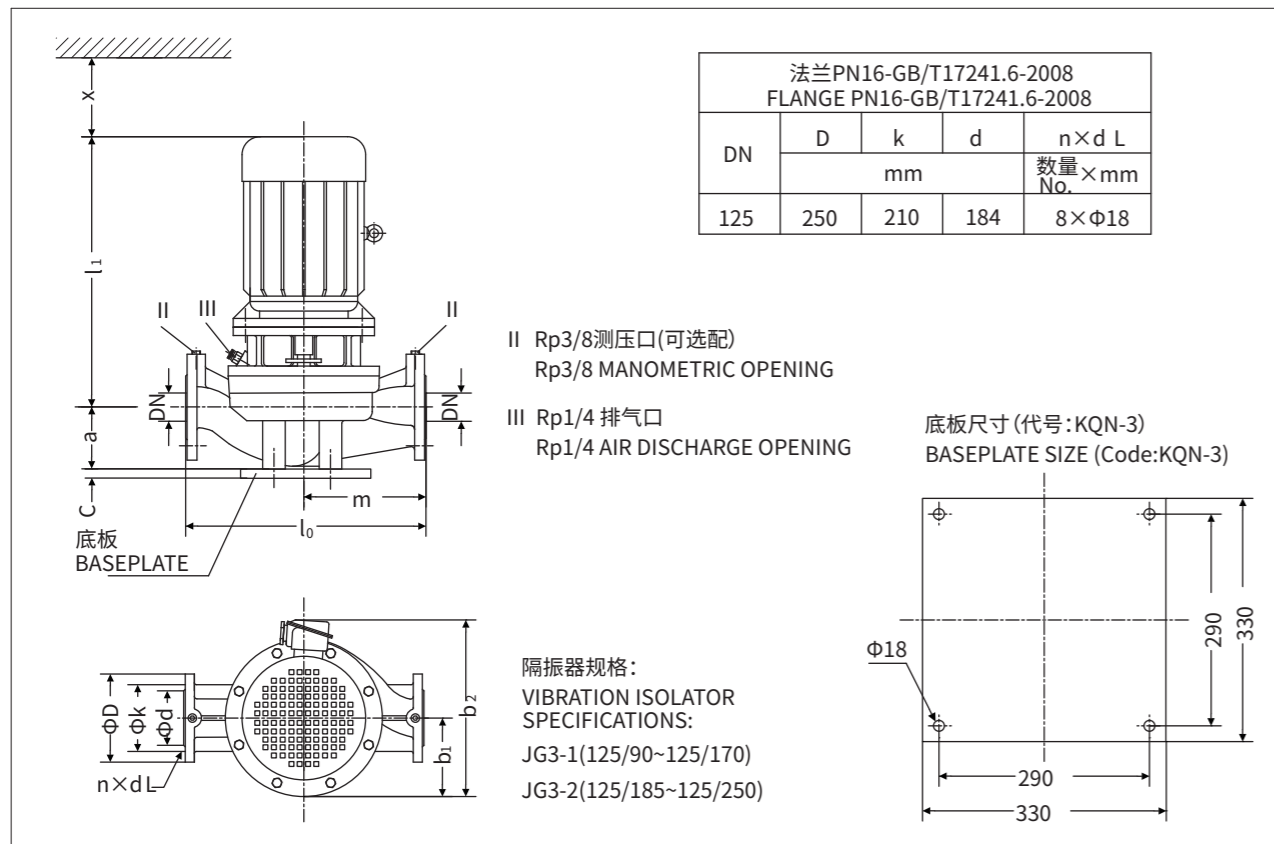

DIMENSION TABLE
KQL尺寸表

型号 TYPE	DN	l ₀	m	a	c	l ₁	b ₁	b ₂	x
		mm							
125KQL143-10-7.5/2	125	645	320	220	30	585	150	360	130
125KQL160-12.5-11/2	125	645	320	220	30	710	175	430	130
125KQL143-16-11/2	125	645	320	220	30	710	225	485	130
125KQL160-20-15/2	125	645	320	220	30	715	225	485	130
125KQL138-24-15/2	125	645	320	220	30	715	225	485	130
125KQL150-28-18.5/2	125	645	320	220	30	747	225	485	130
125KQL160-32-22/2	125	645	320	220	30	789	250	530	130
125KQL138-38-22/2	125	700	350	210	30	792	250	530	140
125KQL150-44-30/2	125	700	350	210	30	860	270	575	140
125KQL160-50-37/2	125	700	350	210	30	860	270	575	140
125KQL138-60-37/2	125	700	350	210	30	860	270	575	140
125KQL150-70-45/2	125	700	350	210	30	895	295	625	140
125KQL160-80-55/2	125	700	350	210	30	955	315	680	140

DIMENSION FIGURE
尺寸图

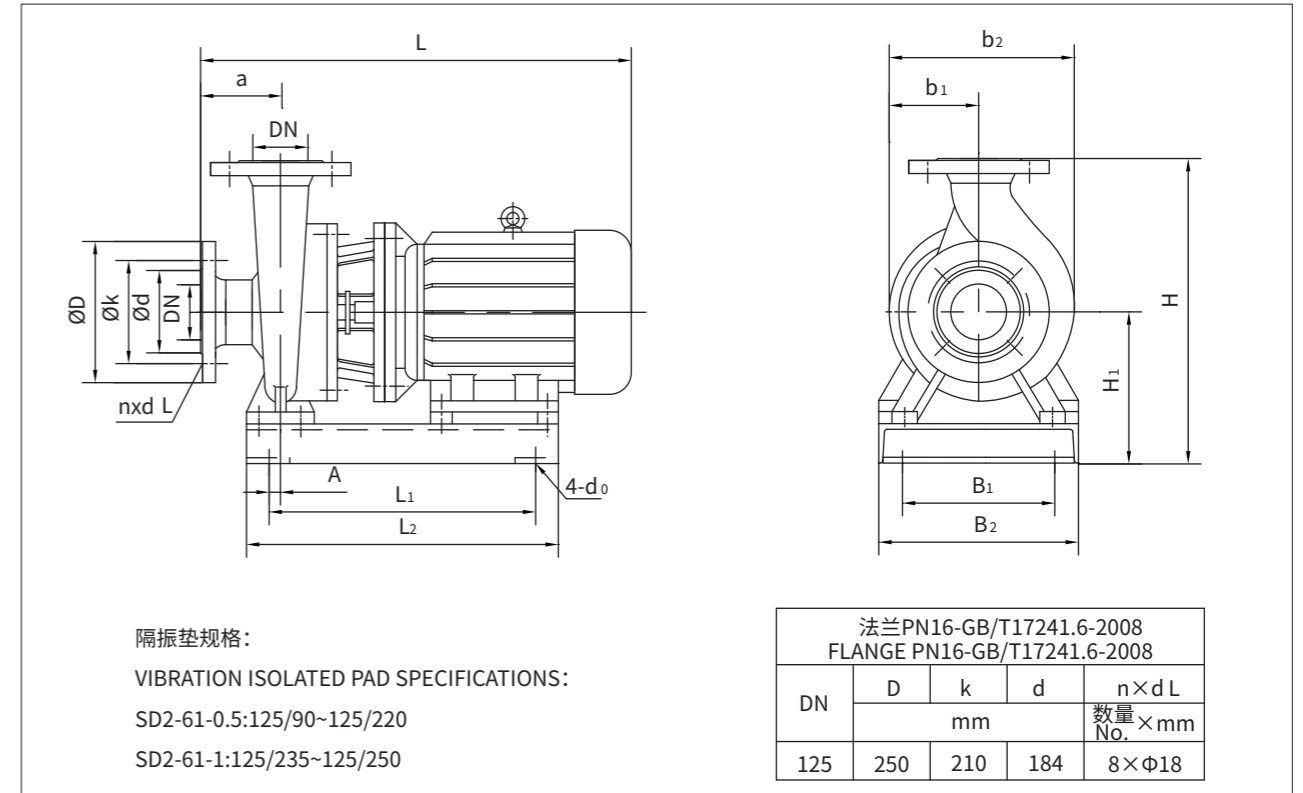

DIMENSION TABLE
KQW尺寸表

型号 TYPE	外形尺寸 Figure dimensions				安装尺寸 Installing dimensions								DN
	L	H	b ₂	b ₁	4-φ ₀	a	L ₁	B ₁	L ₂	B ₂	H ₁	A	
125KQW143-10-7.5/2	710	567	355	175	4-φ15	125	385	220	485	320	277	30	125
125KQW160-12.5-11/2	840	567	355	175	4-φ15	125	485	220	585	320	277	30	125
125KQW143-16-11/2	840	567	355	175	4-φ15	125	485	220	585	320	277	30	125
125KQW160-20-15/2	840	567	355	175	4-φ15	125	485	220	585	320	277	30	125
125KQW138-24-15/2	840	567	355	175	4-φ15	125	485	220	585	320	277	30	125
125KQW150-28-18.5/2	870	567	355	175	4-φ15	125	530	220	630	320	277	30	125
125KQW160-32-22/2	910	575	380	190	4-φ15	125	535	260	635	360	285	30	125
125KQW138-38-22/2	925	625	393	190	4-φ15	125	550	260	650	360	305	30	125
125KQW150-44-30/2	985	624	420	210	4-φ15	125	635	300	735	400	304	30	125
125KQW160-50-37/2	985	624	420	210	4-φ15	125	635	300	735	400	304	30	125
125KQW138-60-37/2	985	624	420	210	4-φ15	125	635	300	735	400	304	30	125
125KQW150-70-45/2	1020	639	470	235	4-φ20	125	665	310	765	440	319	30	125
125KQW160-80-55/2	1080	697	550	275	4-φ20	125	730	370	830	500	377	30	125

PERFORMANCE DATA
参数表

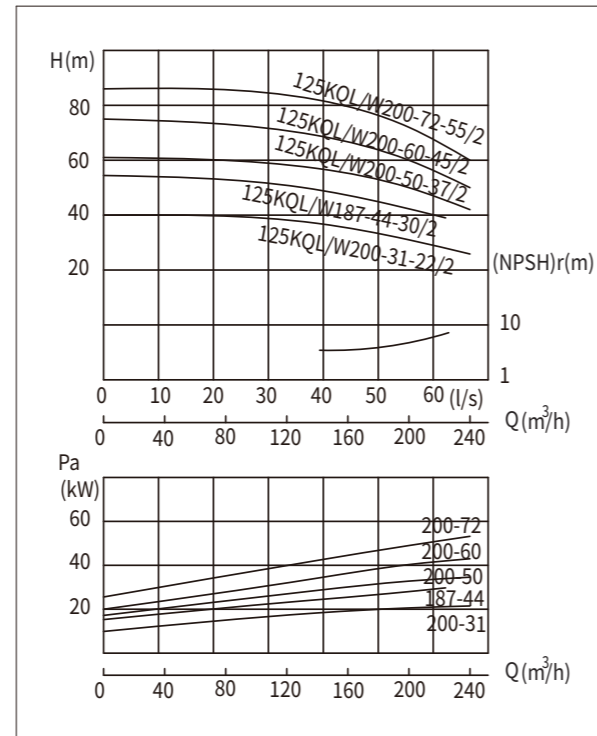
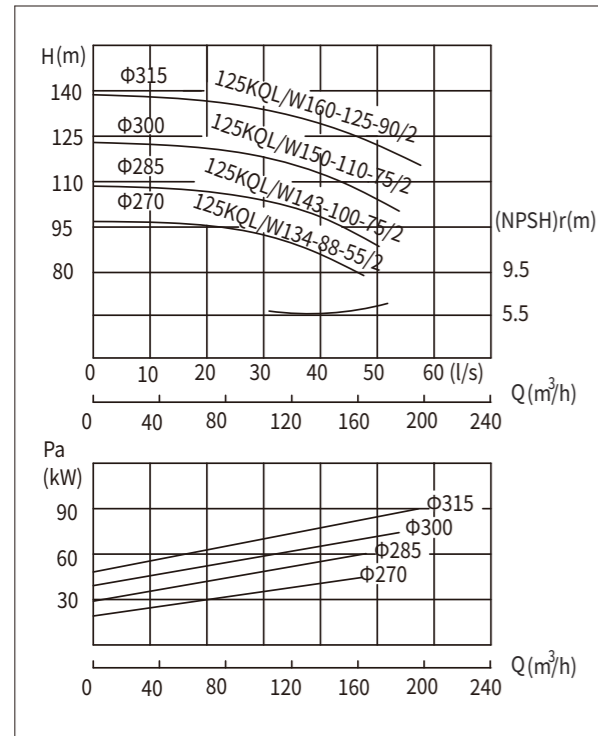

型号 TYPE	流量 Capacity		扬程 Head (m)	转速 Speed (r/min)	效率 Efficiency (%)	电机 功率 Power (kW)	必需 汽蚀 余量 (NPSH)r (m)	重量 Weight (kg)
	(m³/h)	(l/s)						
125KQL/W134-88-55/2	80.5	22.4	96	2960	73	55	5	512
	134	37.2	88					
	161	44.7	81					
125KQL/W143-100-75/2	86	23.9	108	2960	74	75	5	766
	143	39.7	100					
	172	47.8	94					
125KQL/W150-110-75/2	90	25	115	2960	75	75	5	693
	150	41.7	110					
	180	50	102					
125KQL/W160-125-90/2	96	26.7	132	2960	76	90	5	808
	160	44.4	125					
	192	53.3	118					
125KQL/W200-31-22/2	140	38.9	37	2960	82	22	6	295
	200	55.6	31					
	240	66.7	28					
125KQL/W187-44-30/2	130	36.1	51.5	2960	82.5	30	6	375
	187	51.9	44					
	224	62.2	39					
125KQL/W200-50-37/2	140	38.9	57	2960	83	37	6	390
	200	55.6	50					
	240	66.7	42					
125KQL/W200-60-45/2	140	38.9	69	2960	81	45	6	480
	200	55.6	60					
	240	66.7	50					
125KQL/W200-72-55/2	140	38.9	82	2960	80	55	6	590
	200	55.6	72					
	240	66.7	57					

DIMENSION FIGURE
尺寸图

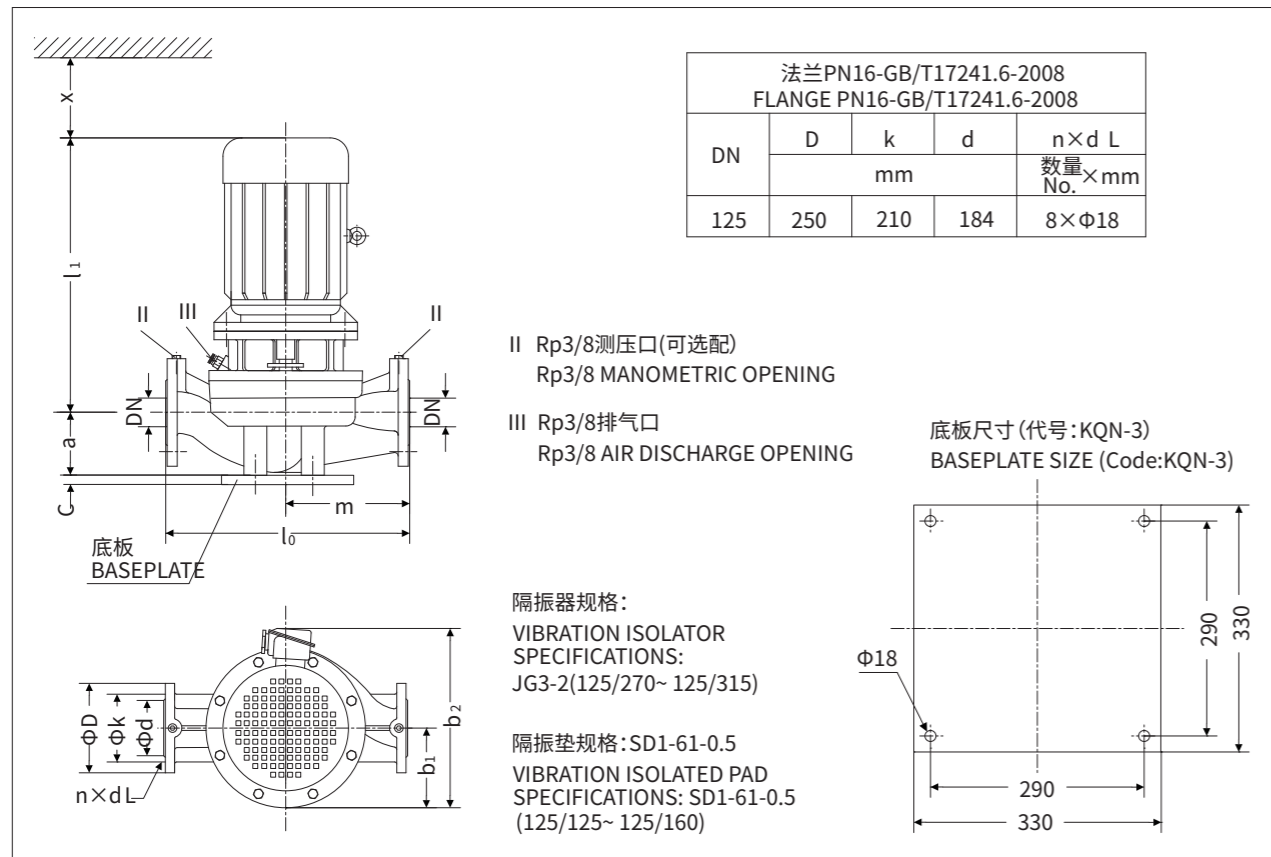

DIMENSION FIGURE
尺寸图

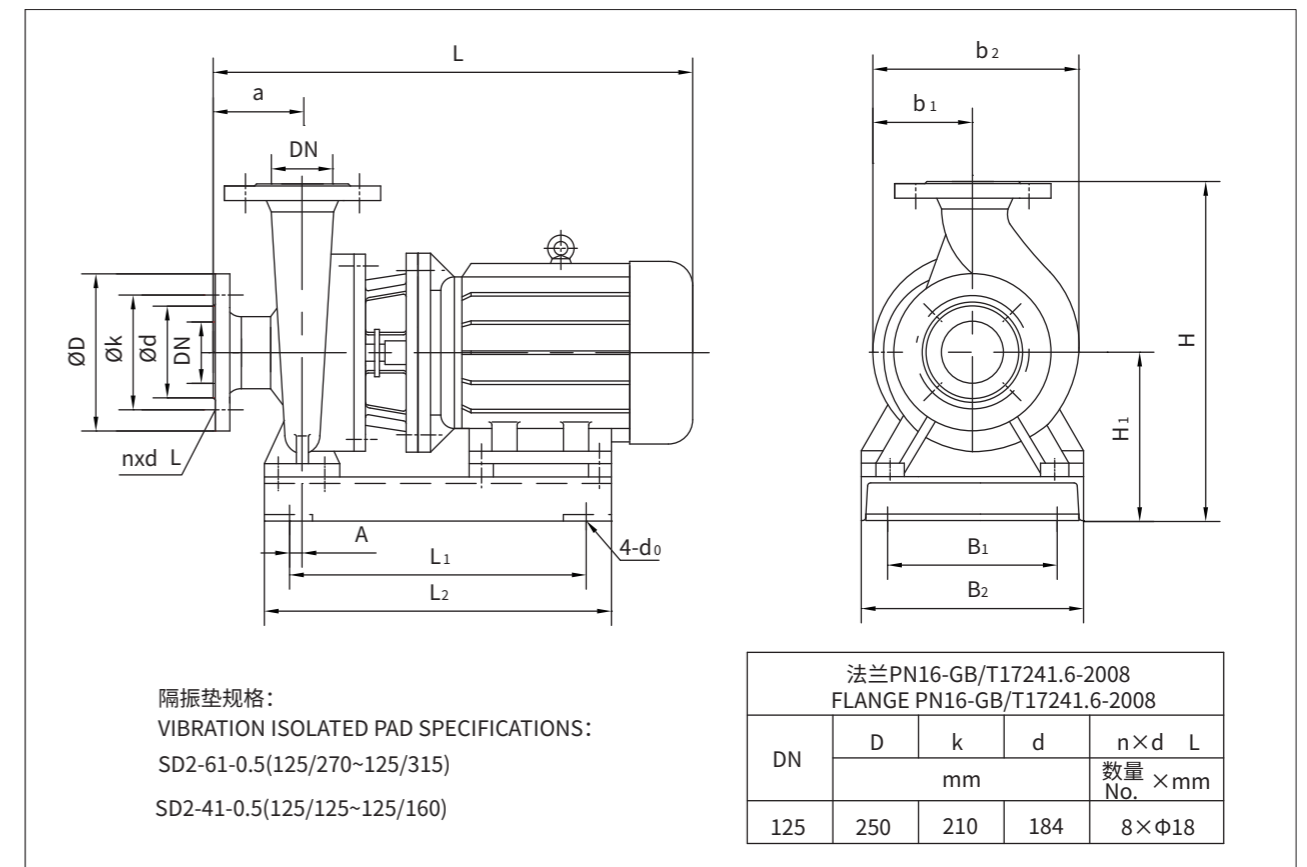

DIMENSION TABLE
KQL尺寸表

型号 TYPE	DN	l ₀	m	a	mm			b ₁	b ₂	x
		c	l ₁	b ₁	b ₂					
125KQL134-88-55/2	125	650	320	175	30	955	275	660	140	
125KQL143-100-75/2	125	650	320	175	30	1021	295	705	140	
125KQL150-110-75/2	125	650	320	175	30	1021	295	705	140	
125KQL160-125-90/2	125	650	320	175	30	1075	295	705	140	
125KQL200-31-22/2	125	645	320	220	30	770	250	530	140	
125KQL187-44-30/2	125	570	285	172	30	860	270	575	140	
125KQL200-50-37/2	125	570	285	172	30	860	270	575	140	
125KQL200-60-45/2	125	700	350	210	30	895	295	625	140	
125KQL200-72-55/2	125	700	350	210	30	965	315	680	140	

DIMENSION TABLE
KQW尺寸表

型号 TYPE	外形尺寸 Figure dimensions				安装尺寸 Installing dimensions							DN	
	L	H	b ₂	b ₁	4-d ₀	a	L ₁	B ₁	L ₂	B ₂	H ₁		A
125KQW134-88-55/2	1095	667	550	275	4-φ20	125	730	370	830	500	347	30	125
125KQW143-100-75/2	1165	701	580	290	4-φ20	125	800	430	900	560	381	30	125
125KQW150-110-75/2	1165	701	580	290	4-φ20	125	800	430	900	560	381	30	125
125KQW160-125-90/2	1215	701	580	290	4-φ20	125	850	430	950	560	381	30	125
125KQW200-31-22/2	905	575	350	175	4-φ15	125	535	260	635	355	285	30	125
125KQW187-44-30/2	965	627	400	200	4-φ15	125	635	300	740	400	307	30	125
125KQW200-50-37/2	965	627	400	200	4-φ15	125	635	300	740	400	307	30	125
125KQW200-60-45/2	1015	643	450	225	4-φ20	125	665	310	765	440	323	30	125
125KQW200-72-55/2	1085	694	550	275	4-φ20	125	730	370	830	500	374	30	125

CHARACTERISTIC CURVE
性能曲线

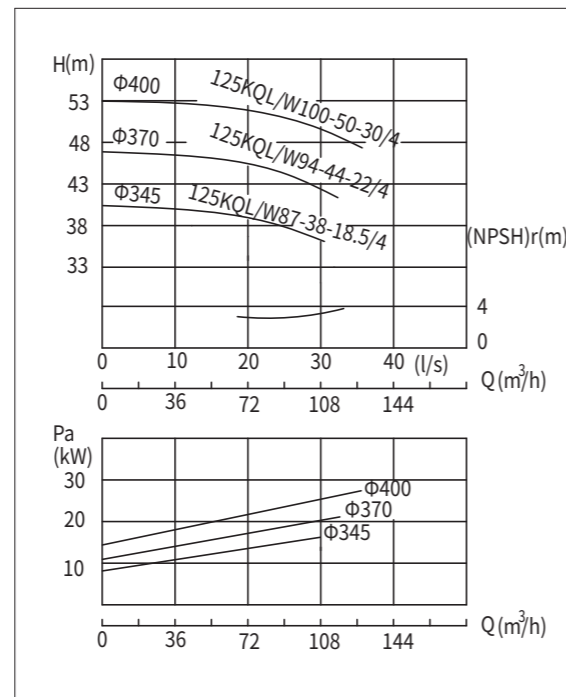
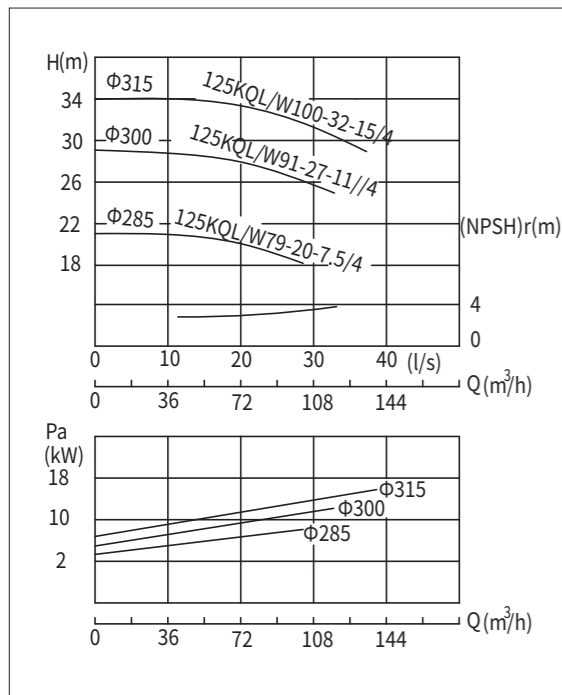
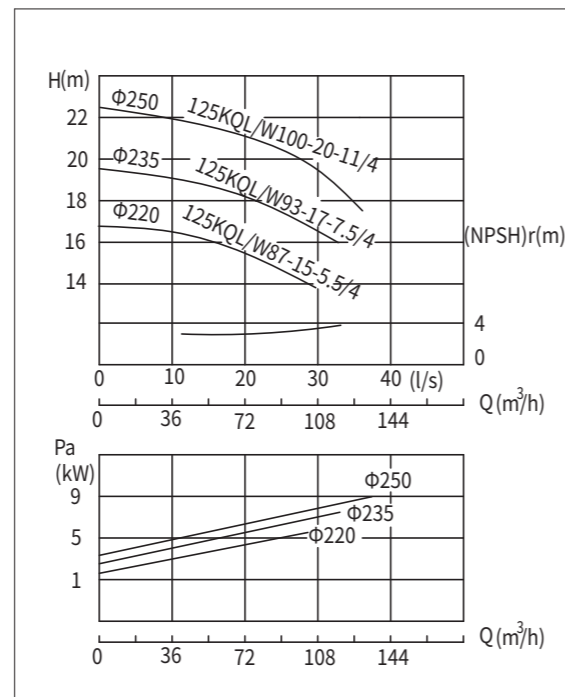
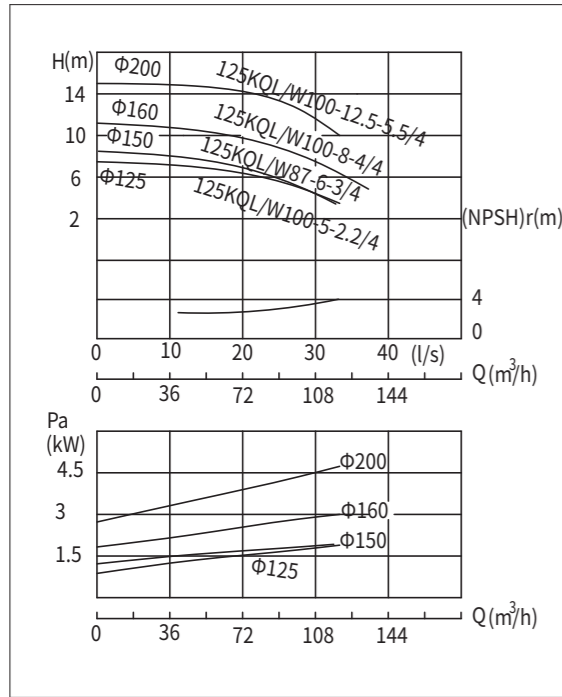

PERFORMANCE DATA
参数表

型号 TYPE	流量 Capacity		扬程 Head (m)	转速 Speed (r/min)	效率 Efficiency (%)	电机 功率 Power (kW)	必需 汽蚀 余量 (NPSH) _r (m)	重量 Weight (kg)
	(m³/h)	(l/s)						
125KQL/W100-5-2.2/4	60	16.67	6.5	1480	78	2.2	3	110
	100	27.8	5					
	120	33.33	4					
125KQL/W87-6-3/4	52	14.5	7.5	1480	79	3	3	113
	87	24.2	6.3					
	104	28.9	5.1					
125KQL/W100-8-4/4	60	16.67	9.4	1480	80	4	3	113
	100	27.8	8					
	120	33.33	6.7					
125KQL/W100-12.5-5.5/4	60	16.67	14	1480	78	5.5	3	185
	100	27.8	12.5					
	120	33.33	11					
125KQL/W87-15-5.5/4	52	14.5	16.4	1480	76	5.5	3	208
	87	24.2	15					
	104	28.9	14					
125KQL/W93-17-7.5/4	56	15.6	19	1480	77	7.5	3	220
	93	25.8	17.4					
	112	31.1	15.5					
125KQL/W120-16-7.5/4	84	23.3	18.5	1480	78	7.5	3	220
	120	33.3	16					
	132	36.7	14.4					
125KQL/W100-20-11/4	60	16.7	21.5	1480	78	11	3	280
	100	27.8	20					
	120	33.3	18					
125KQL/W79-20-7.5/4	47	13.1	21	1480	72	7.5	3	230
	79	21.9	20					
	95	26.4	18					
125KQL/W91-27-11/4	55	15.3	29	1480	73	11	3	276
	91	25.3	27					
	110	30.6	22					
125KQL/W100-32-15/4	60	16.7	35	1480	74	15	3	305
	100	27.8	32					
	120	33.3	27					
125KQL/W87-38-18.5/4	52.3	14.5	39	1480	67	18.5	3	311
	87	24.2	38					
	105	29.2	37					
125KQL/W94-44-22/4	56.4	15.7	46	1480	68	22	3	368
	94	26.1	44					
	113	31.4	41					
125KQL/W100-50-30/4	60	16.7	52	1480	69	30	3	450
	100	27.8	50					
	120	33.3	47					

DIMENSION FIGURE
尺寸图

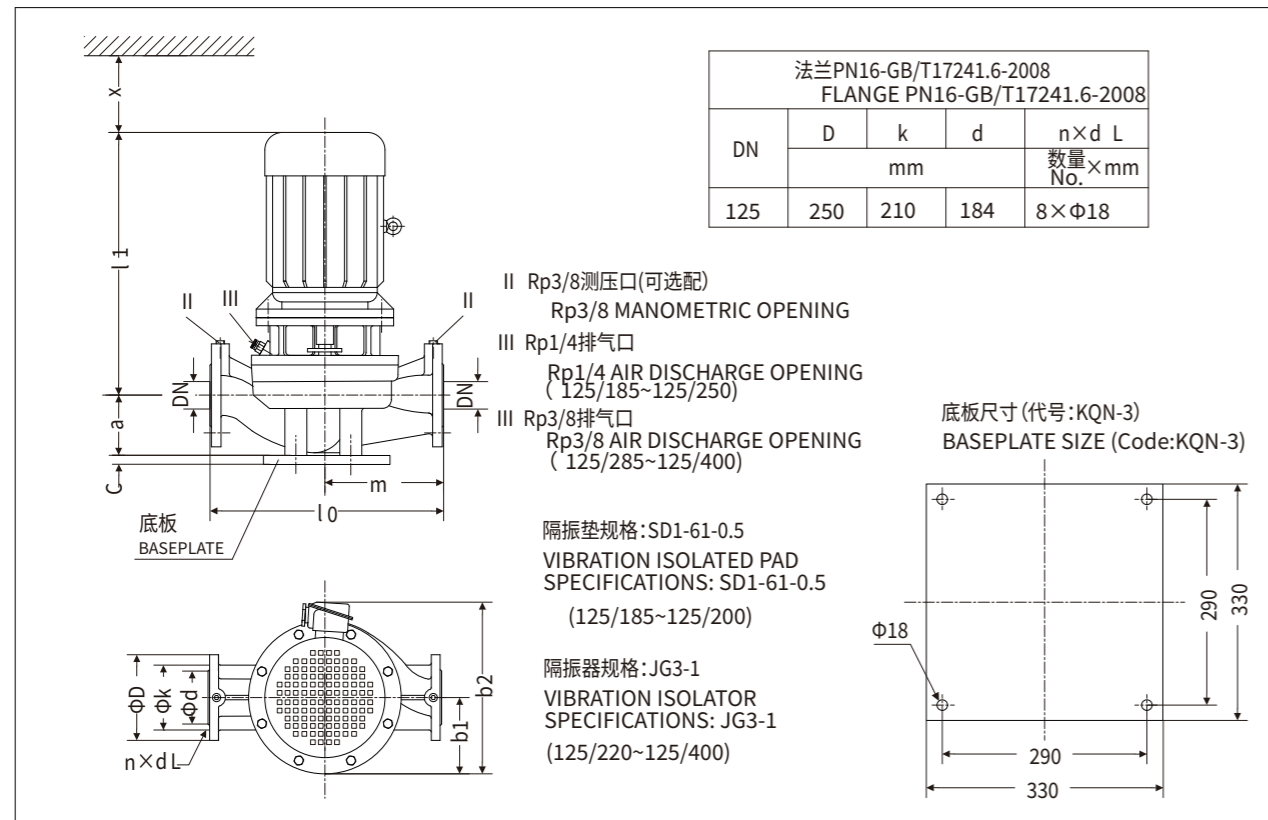

DIMENSION FIGURE
尺寸图

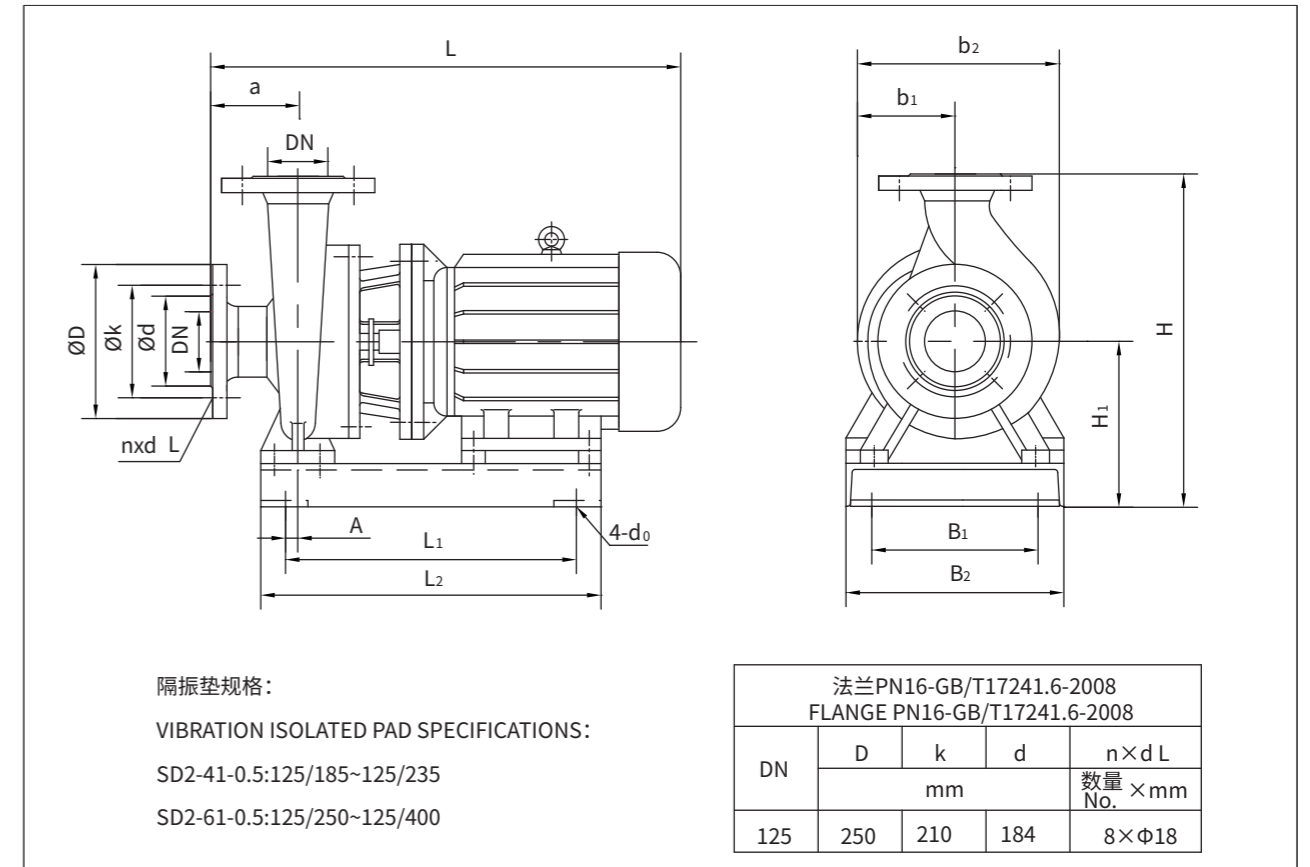

DIMENSION TABLE
KQL尺寸表

型号 TYPE	DN	l ₀	m	a	c	l ₁	b ₁	b ₂	x
		mm							
125KQL100-5-2.2/4	125	610	280	210	30	512	145	335	130
125KQL87-6-3/4	125	610	280	210	30	512	145	335	130
125KQL100-8-4/4	125	610	280	210	30	547	145	335	130
125KQL100-12.5-5.5/4	125	700	335	200	30	588	185	395	130
125KQL87-15-5.5/4	125	700	335	200	30	588	185	395	130
125KQL93-17-7.5/4	125	700	335	200	30	638	185	395	130
125KQL120-16-7.5/4	125	700	335	200	30	638	185	395	130
125KQL100-20-11/4	125	700	335	200	30	718	225	485	130
125KQL91-27-11/4	125	785	335	210	30	732	240	515	130
125KQL100-32-15/4	125	785	335	210	30	762	240	515	130
125KQL87-38-18.5/4	125	785	385	210	30	802	250	530	130
125KQL94-44-22/4	125	785	385	210	30	852	250	530	130
125KQL100-50-30/4	125	785	385	210	30	862	270	575	130

DIMENSION TABLE
KQW尺寸表

型号 TYPE	外形尺寸 Figure dimensions					安装尺寸 Installing dimensions							DN
	L	H	b ₂	b ₁	4-d ₀	a	L ₁	B ₁	L ₂	B ₂	H ₁	A	
125KQW100-5-2.2/4	637	557	350	160	4-Φ15	125	340	220	440	320	277	30	125
125KQW87-6-3/4	637	557	350	160	4-Φ15	125	340	220	440	320	277	30	125
125KQW100-8-4/4	672	557	350	160	4-Φ15	125	350	220	450	320	277	30	125
125KQW100-12.5-5.5/4	702	669	412	200	4-Φ15	125	390	300	490	400	334	30	125
125KQW87-15-5.5/4	702	669	412	200	4-Φ15	125	390	300	490	400	334	30	125
125KQW93-17-7.5/4	752	669	412	200	4-Φ15	125	425	300	525	400	334	30	125
125KQW120-16-7.5/4	752	669	412	200	4-Φ15	125	425	300	525	400	334	30	125
125KQW100-20-11/4	842	669	412	200	4-Φ15	125	485	300	585	400	334	30	125
125KQW79-20-7.5/4	767	767	518	250	4-Φ20	125	460	370	560	500	382	50	125
125KQW91-27-11/4	857	767	518	250	4-Φ20	125	520	370	620	500	382	50	125
125KQW100-32-15/4	887	767	518	250	4-Φ20	125	565	370	665	500	382	50	125
125KQW87-38-18.5/4	927	767	518	250	4-Φ20	125	570	370	670	500	382	50	125
125KQW94-44-22/4	977	767	518	250	4-Φ20	125	610	370	710	500	382	50	125
125KQW100-50-30/4	987	762	518	250	4-Φ20	125	660	370	760	500	377	50	125

CHARACTERISTIC CURVE
性能曲线

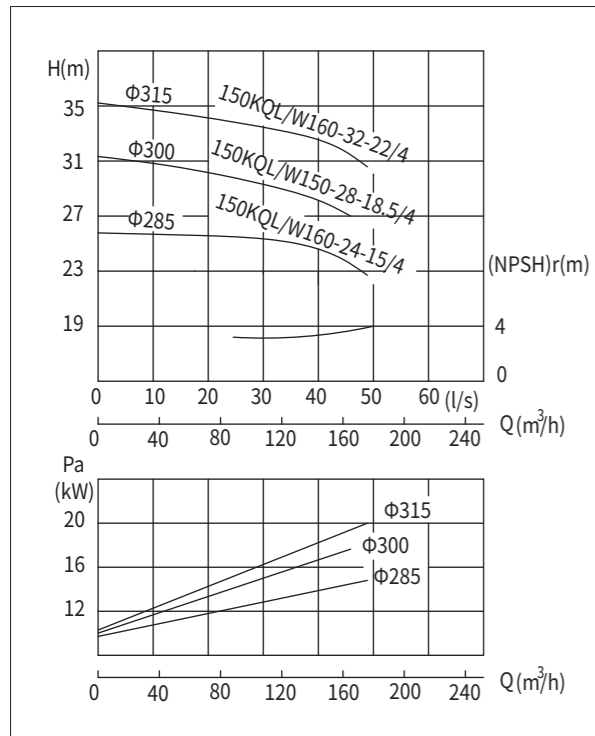
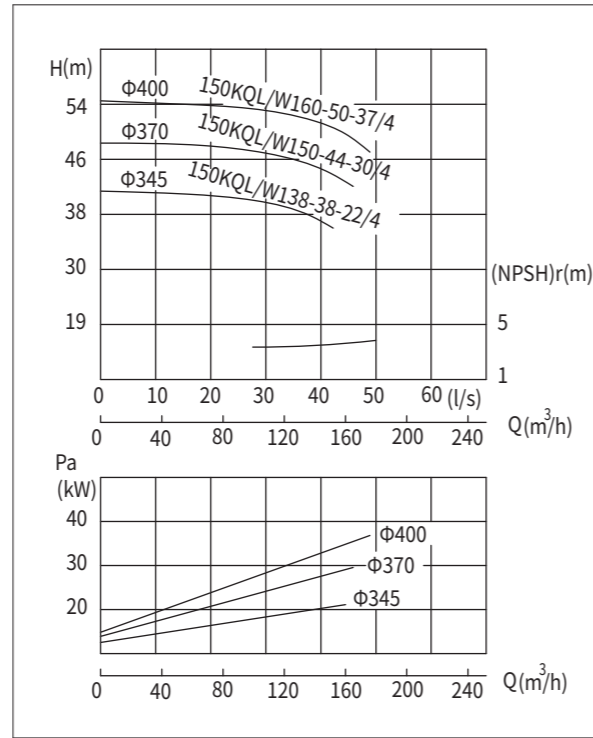
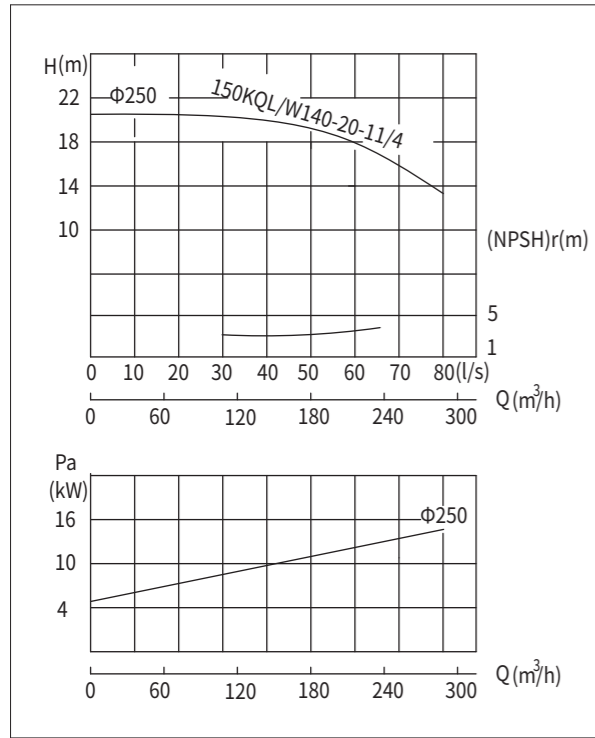

PERFORMANCE DATA
参数表

TYPE	流量 Capacity		扬程 Head (m)	转速 Speed (r/min)	效率 Efficiency (%)	电机功率 Power (kW)	必需汽蚀余量 (NPSH)r (m)	重量 Weight (kg)
	(m³/h)	(l/s)						
150KQL/W140-20-11/4	98	27.2	21	1480	79	11	3	260
	140	38.9	20					
	154	42.8	18.4					
150KQL/W160-24-15/4	112	31.1	25.2	1480	76	15	3	300
	160	44.4	24					
	176	48.9	22.5					
150KQL/W150-28-18.5/4	105	29.2	29.4	1480	78	18.5	3	330
	150	41.7	28					
	165	45.8	26.5					
150KQL/W160-32-22/4	112	31.1	33.6	1480	79	22	3	350
	160	44.4	32					
	176	48.9	30					
150KQL/W138-38-22/4	96.6	26.8	39.9	1480	72	22	3.5	352
	138	38.3	38					
	151.8	42.2	36.2					
150KQL/W150-44-30/4	105	29.2	46.2	1480	73	30	3.5	423
	150	41.7	44					
	165	45.8	41.5					
150KQL/W160-50-37/4	112	31.1	52.5	1480	74.7	37	3.5	440
	160	44.4	50					
	176	48.9	47					

DIMENSION FIGURE
尺寸图

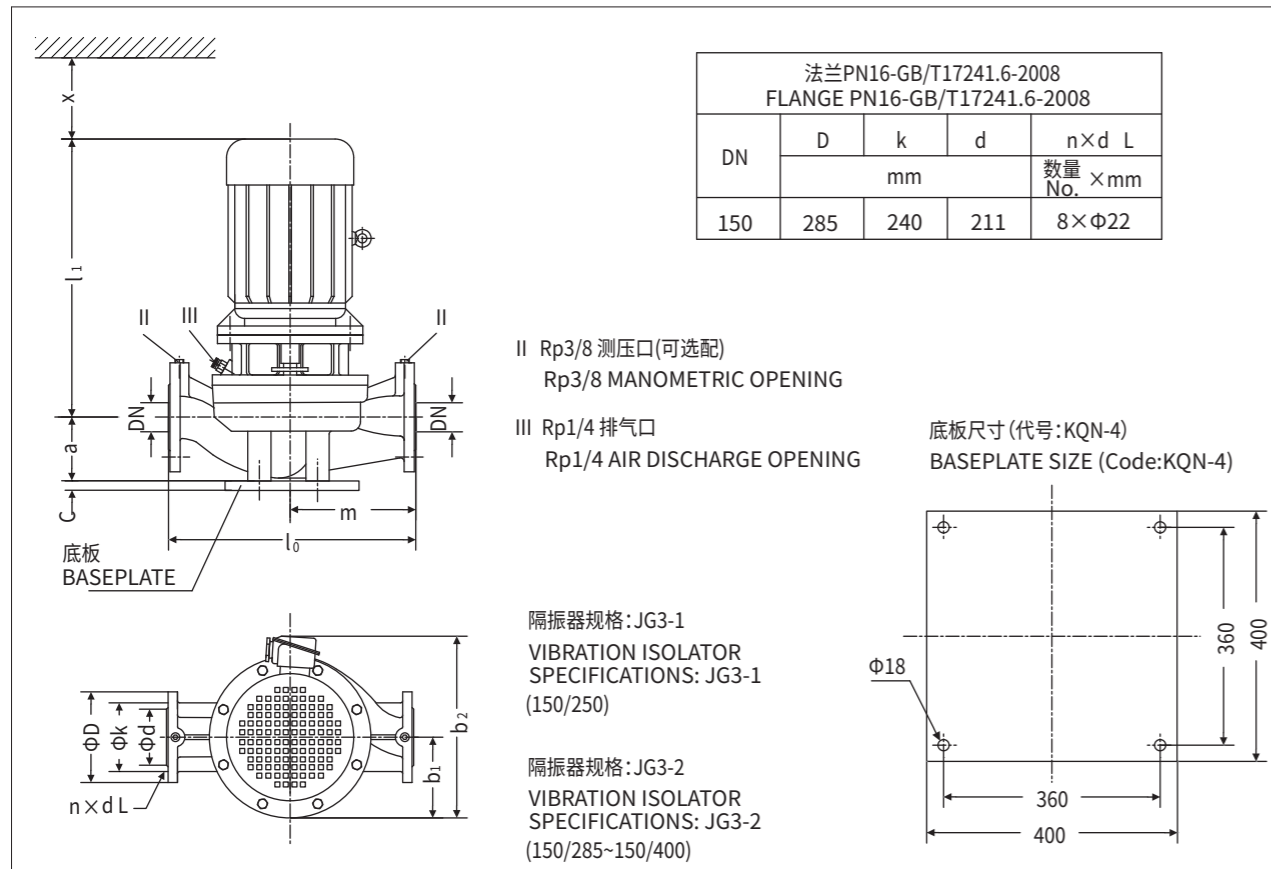

DIMENSION FIGURE
尺寸图

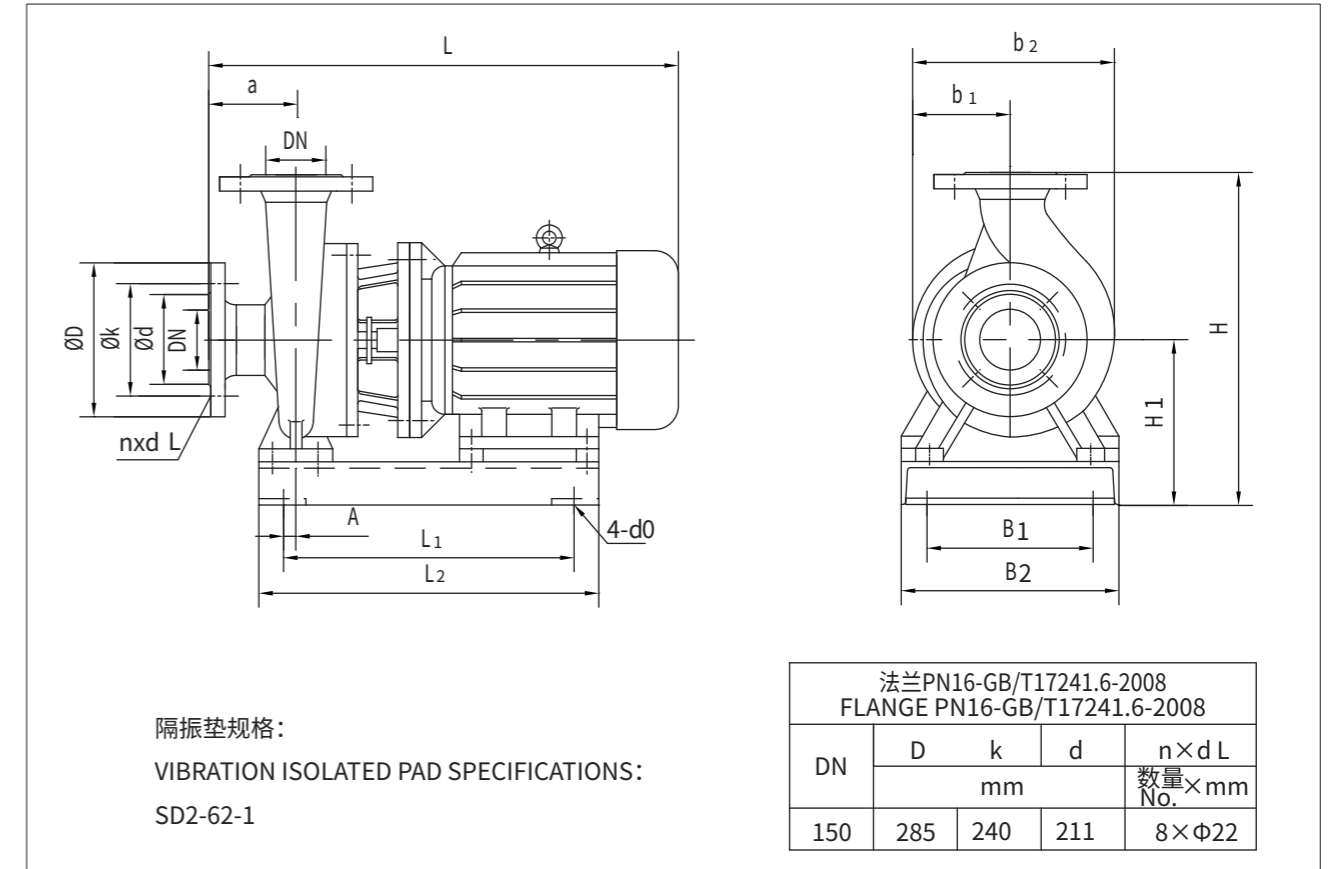

DIMENSION TABLE
KQL尺寸表

型号 TYPE	DN	外形尺寸 Figure dimensions							
		l0	m	a	c	l1	b1	b2	x
150KQL140-20-11/4	150	880	430	265	37	725	225	485	150
150KQL160-24-15/4	150	880	430	265	37	758	250	530	155
150KQL150-28-18.5/4	150	880	430	274	37	795	250	530	155
150KQL160-32-22/4	150	880	430	274	37	845	250	530	155
150KQL138-38-22/4	150	880	430	274	37	845	250	530	155
150KQL150-44-30/4	150	970	480	280	37	845	270	575	155
150KQL160-50-37/4	150	970	480	280	37	859	295	625	155

DIMENSION TABLE
KQW尺寸表

型号 TYPE	外形尺寸 Figure dimensions				安装尺寸 Installing dimensions								DN
	L	H	b2	b1	4-d0	a	L1	B1	L2	B2	H1	A	
150KQW140-20-11/4	872	759	433	200	4-φ15	140	500	300	600	400	359	30	150
150KQW160-24-15/4	902	759	433	250	4-φ20	140	545	300	645	400	359	30	150
150KQW150-28-18.5/4	945	812	530	250	4-φ20	140	565	370	665	500	382	50	150
150KQW160-32-22/4	995	812	530	250	4-φ20	140	600	370	700	500	382	50	150
150KQW138-38-22/4	995	812	530	250	4-φ20	140	600	370	700	500	382	50	150
150KQW150-44-30/4	996	867	530	250	4-φ20	140	650	370	750	500	417	50	150
150KQW160-50-37/4	1006	862	530	250	4-φ20	140	655	370	762	500	412	50	150

CHARACTERISTIC CURVE
性能曲线

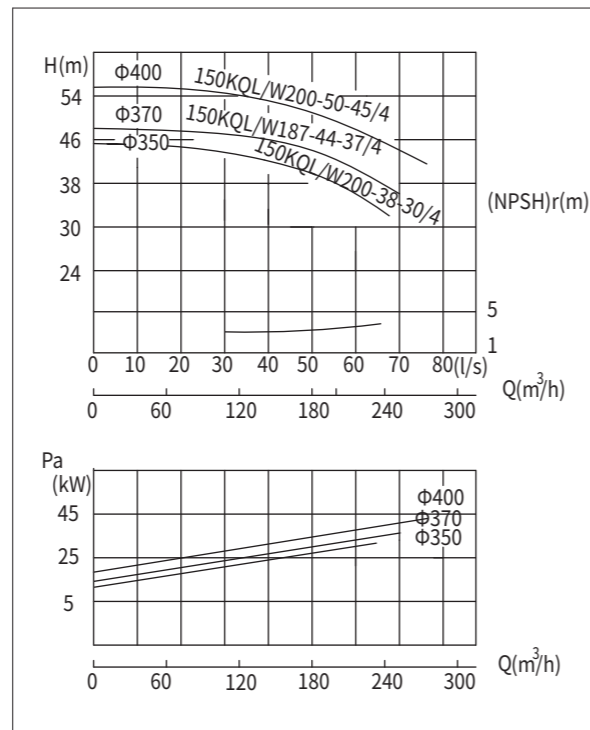
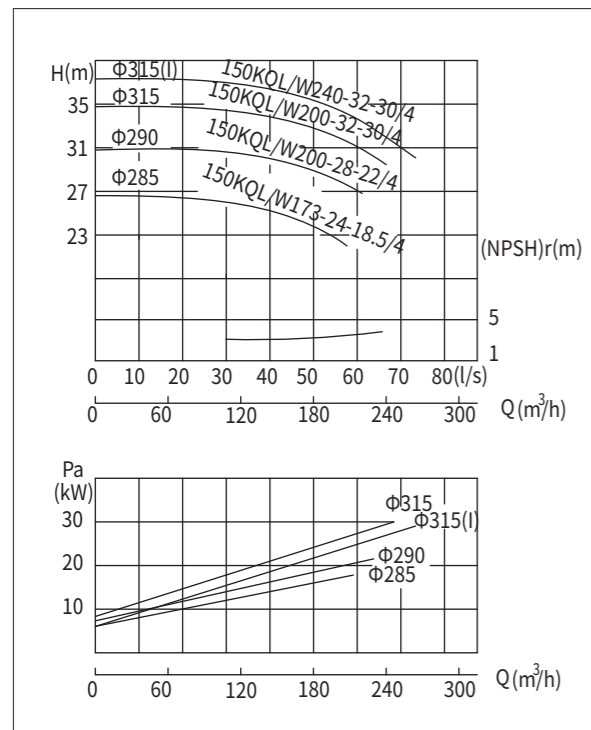
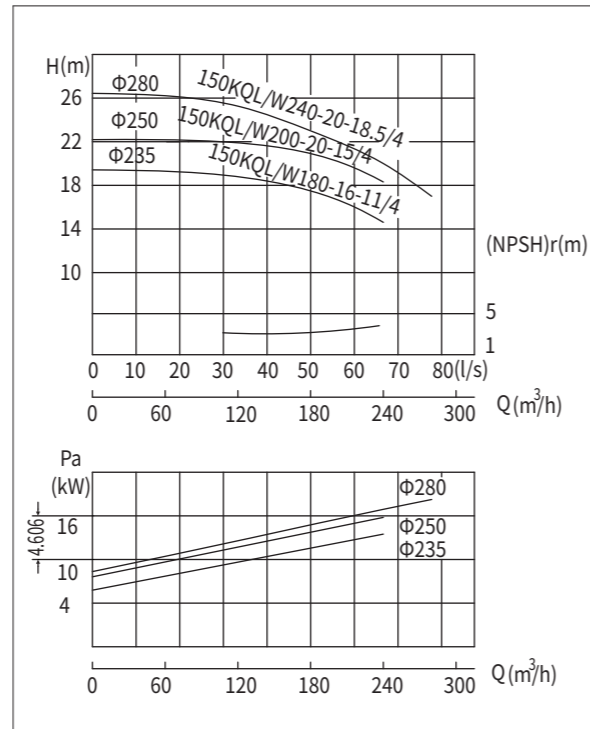
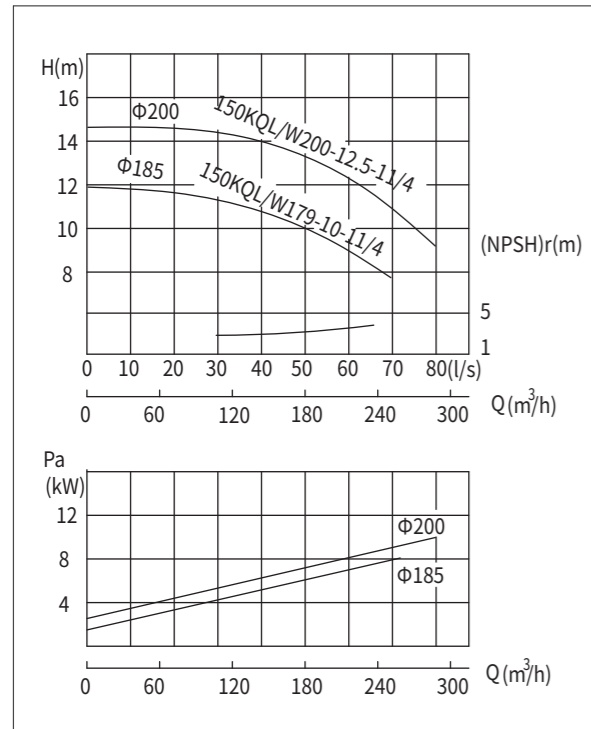

PERFORMANCE DATA
参数表

型号 TYPE	流量 Capacity		扬程 Head (m)	转速 Speed (r/min)	效率 Efficiency (%)	电机 功率 Power (kW)	必需 汽蚀 余量 (NPSH)r (m)	重量 Weight (kg)
	(m³/h)	(l/s)						
150KQL/W179-10-11/4	125	34.7	11.6	1480	80	11	3	260
	179	49.7	10					
	215	59.7	8					
150KQL/W200-12.5-11/4	140	38.9	14.1	1480	82	11	3	265
	200	55.6	12.5					
	240	66.7	10.6					
150KQL/W180-16-11/4	126	35.0	16.8	1480	81.8	11	3	270
	180	50.0	16					
	198	55.0	14.4					
150KQL/W200-20-15/4	140	38.9	21.8	1480	82.8	15	3	278
	200	55.6	20					
	220	61.1	18.5					
150KQL/W240-20-18.5/4	180	50.0	23	1480	82	18.5	3	315
	240	66.7	20					
	280	77.8	17					
150KQL/W173-24-18.5/4	121	33.6	25.8	1480	79	18.5	3.5	324
	173	48.1	24					
	208	57.8	20.7					
150KQL/W200-28-22/4	140	38.9	31	1480	81.7	22	3.5	345
	200	55.6	28					
	220	61.1	25.2					
150KQL/W200-32-30/4	140	38.9	35	1480	81.7	30	3.5	402
	200	55.6	32					
	240	66.7	28					
150KQL/W240-32-30/4	171	47.5	35.2	1480	80	30	4	430
	240	68.1	32					
	264	75.0	28.8					
150KQL/W200-38-30/4	140	38.9	39.9	1480	77	30	3.5	430
	200	55.6	38					
	220	58.3	36					
150KQL/W187-44-37/4	131	36.4	46.6	1480	76	37	3.5	510
	187	51.9	44					
	225	62.5	39					
150KQL/W200-50-45/4	140	38.9	53	1480	77	45	3.5	531
	200	55.6	50					
	240	66.7	44					

DIMENSION FIGURE
尺寸图

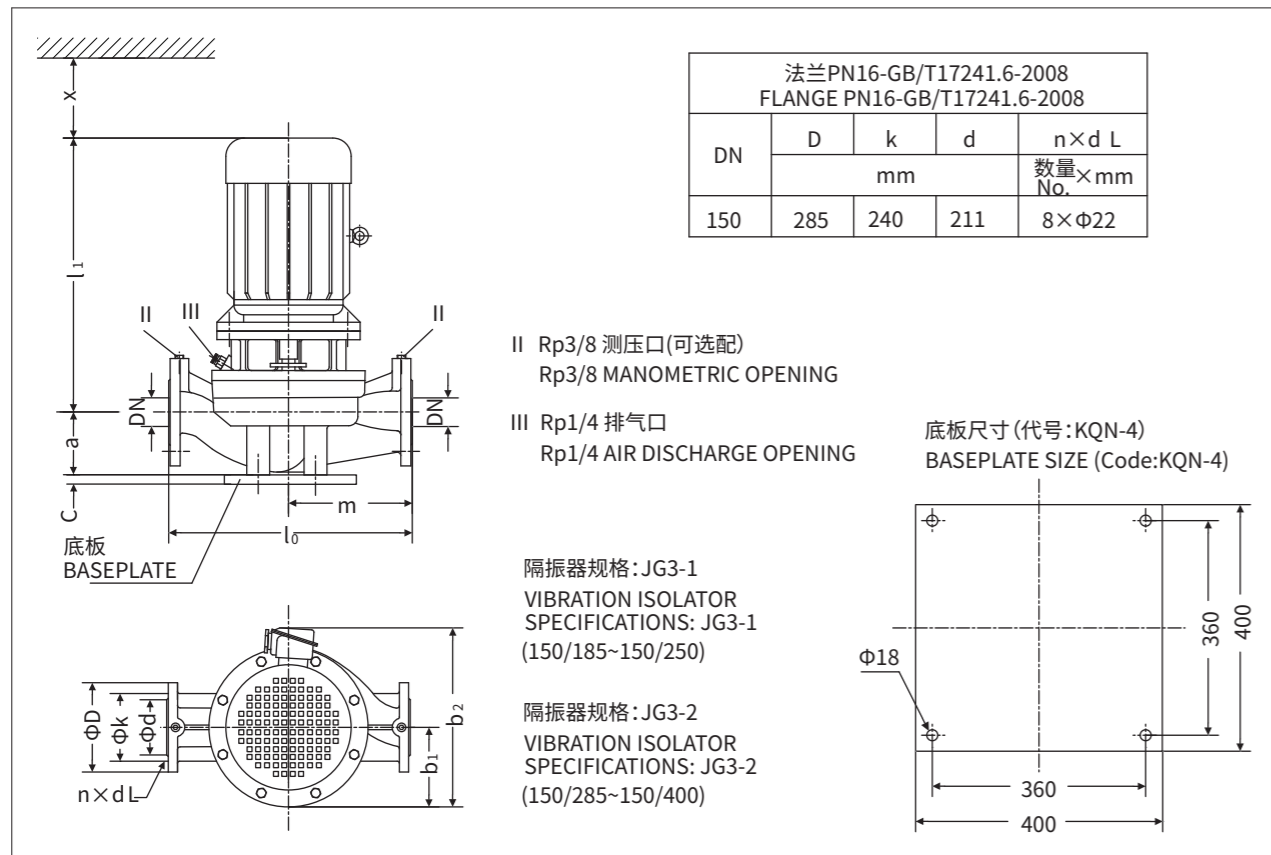

DIMENSION TABLE
KQL尺寸表

型号 TYPE	DN	l ₀	m	a	c	l ₁	b ₁	b ₂	x
		mm							
150KQL179-10-11/4	150	880	430	265	37	725		485	150
150KQL200-12.5-11/4	150	880	430	265	37	725	225	485	150
150KQL180-16-11/4	150	880	430	265	37	725	225	485	150
150KQL200-20-15/4	150	880	430	265	37	757	225	485	150
150KQL240-20-18.5/4	150	880	430	265	37	797	225	485	150
150KQL173-24-18.5/4	150	880	430	274	37	795	250	530	155
150KQL200-28-22/4	150	880	430	274	37	845	250	530	155
150KQL200-32-30/4	150	880	430	274	37	845	270	575	155
150KQL240-32-30/4	150	880	430	274	37	845	270	575	155
150KQL200-38-30/4	150	880	430	274	37	845	270	575	155
150KQL187-44-37/4	150	970	480	280	37	859	295	625	155
150KQL200-50-45/4	150	970	480	280	37	887	295	625	155

DIMENSION FIGURE
尺寸图

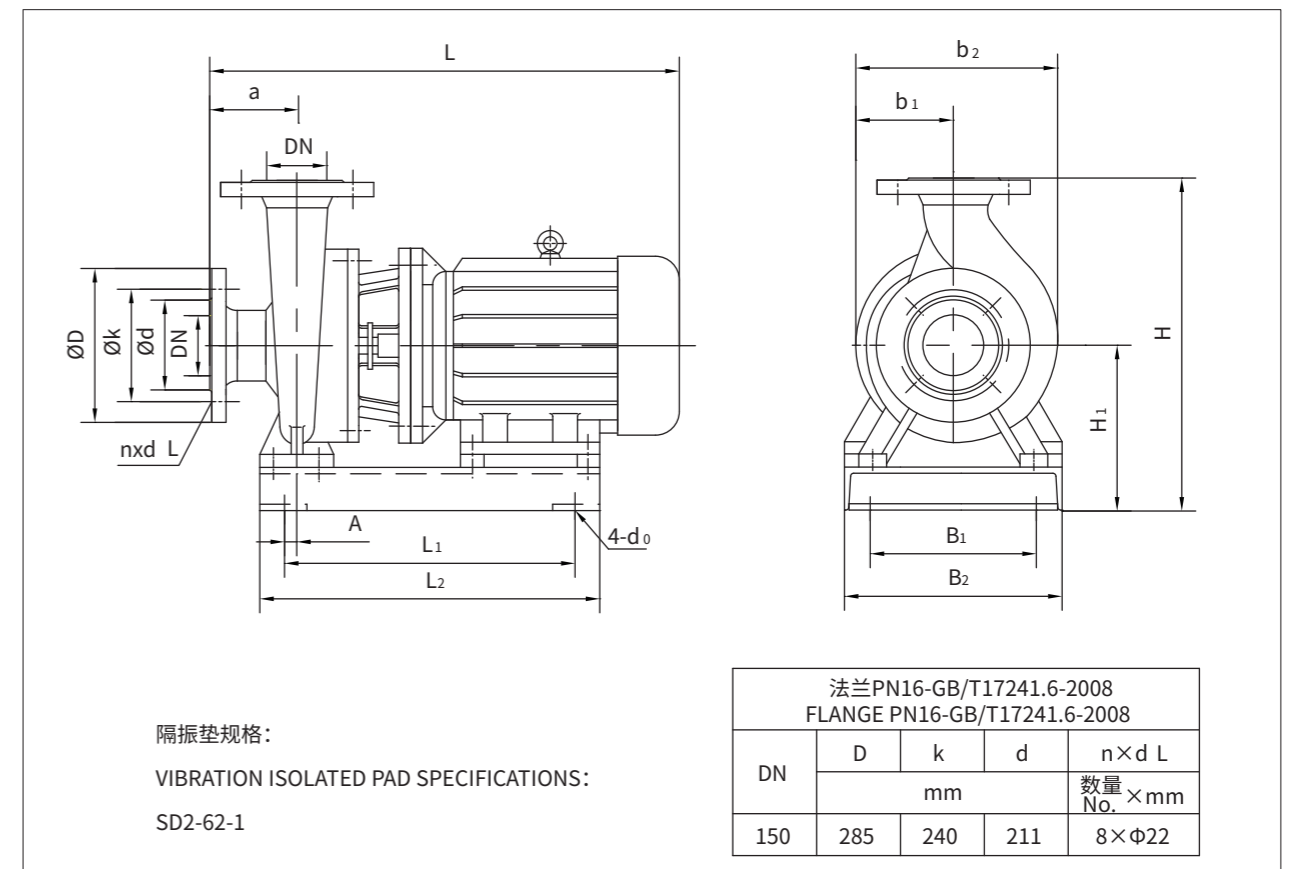

DIMENSION TABLE
KQW尺寸表

型号 TYPE	外形尺寸 Figure dimensions				安装尺寸 Installing dimensions								DN
	L	H	b ₂	b ₁	4-d ₀	a	L ₁	B ₁	L ₂	B ₂	H ₁	A	
150KQW179-10-11/4	872	759	433	200	4-φ15	140	500	300	600	400	359	30	150
150KQW200-12.5-11/4	872	759	433	200	4-φ15	140	500	300	600	400	359	30	150
150KQW180-16-11/4	872	759	433	200	4-φ15	140	500	300	600	400	359	30	150
150KQW200-20-15/4	905	759	433	200	4-φ15	140	545	300	645	400	359	30	150
150KQW240-20-18.5/4	945	759	433	200	4-φ15	140	550	300	655	410	359	30	150
150KQW173-24-18.5/4	945	812	530	250	4-φ20	140	565	370	665	500	382	50	150
150KQW200-28-22/4	995	812	530	250	4-φ20	140	600	370	700	500	382	50	150
150KQW200-32-30/4	995	809	530	250	4-φ20	140	650	370	750	500	379	50	150
150KQW240-32-30/4	995	809	530	250	4-φ20	140	650	370	750	500	379	50	150
150KQW200-38-30/4	995	809	530	250	4-φ20	140	650	370	750	500	379	50	150
150KQW187-44-37/4	1005	864	530	250	4-φ20	140	655	370	762	500	414	50	150
150KQW200-50-45/4	1030	864	530	250	4-φ20	140	680	370	780	500	414	50	150

CHARACTERISTIC CURVE
性能曲线

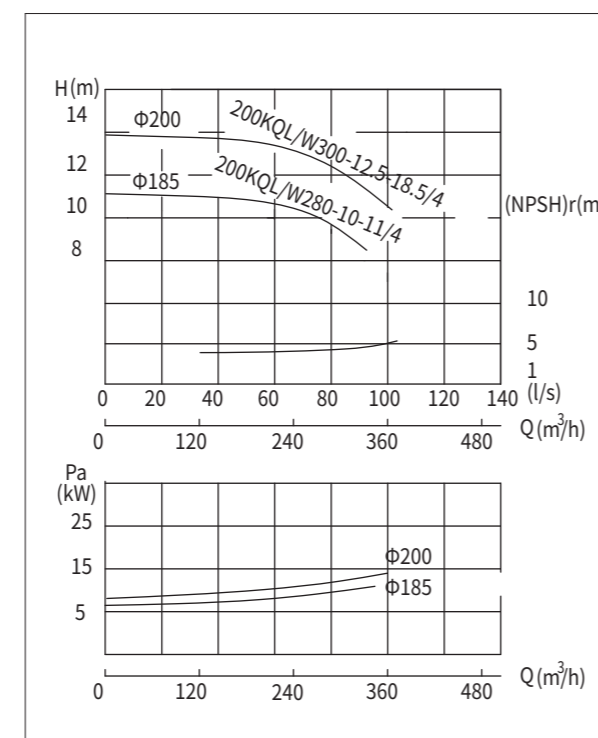
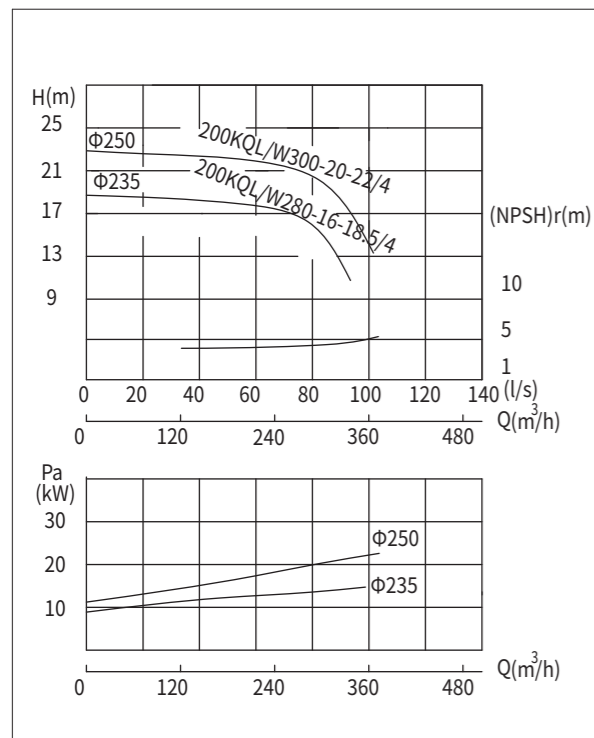
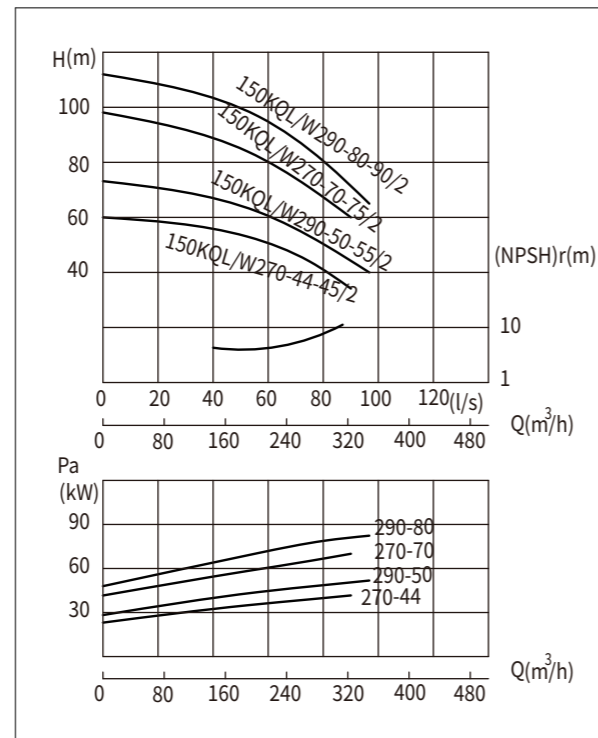
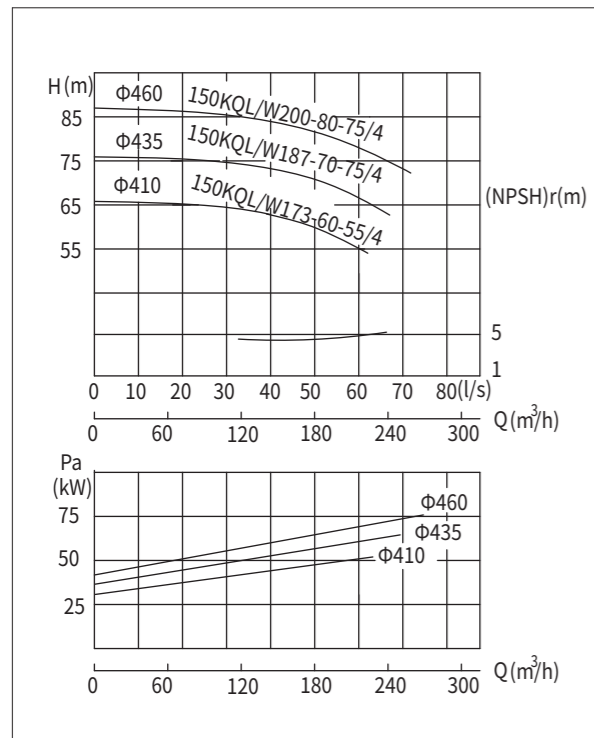

PERFORMANCE DATA
参数表

型号 TYPE	流量 Capacity		扬程 Head (m)	转速 Speed (r/min)	效率 Efficiency (%)	电机 功率 Power (kW)	必需 汽蚀 余量 (NPSH)r (m)	重量 Weight (kg)
	(m³/h)	(l/s)						
150KQL/W173-60-55/4	121	33.6	64	1480	69	55	4	703
	173	48.1	60					
	208	57.7	55.5					
150KQL/W180-70-55/2	126	35.0	75	2960	74	55	6	590
	180	50.0	70					
	216	60.0	64					
150KQL/W187-70-75/4	131	36.4	74	1480	70	75	4	848
	187	51.9	70					
	224	62.3	64					
150KQL/W200-80-75/2	140	38.9	86	2960	75	75	6	630
	200	55.6	80					
	240	66.7	72					
150KQL/W200-80-75/4	140	38.9	85	1480	71.3	75	4	856
	200	55.6	80					
	240	66.7	75					
150KQL/W270-44-45/2	189	52.5	53	2960	83	55	8.5	433
	270	75.0	44					
	324	90.0	30					
150KQL/W290-50-55/2	203	56.4	62	2960	81	55	8.5	538
	290	80.6	50					
	348	96.7	41					
150KQL/W270-70-75/2	189	52.5	88	2960	79	75	8	740
	270	75.0	70					
	324	90.0	60					
150KQL/W290-80-90/2	203	56.4	99	2960	80	90	8	790
	290	80.6	80					
	348	96.7	62					
200KQL/W280-10-11/4	196	54.4	11.5	1480	82	11	4	326
	280	77.8	10					
	308	85.6	8.6					
200KQL/W300-12.5-15/4	210	58.3	15	1480	83	15	4	345
	300	83.3	12.5					
	330	91.7	11					
200KQL/W280-16-18.5/4	196	54.4	18	1480	82	18.5	4	339
	280	77.8	16					
	336	93.3	13					
200KQL/W300-20-22/4	210	58.3	21.5	1480	84	22	4	425
	300	83.3	20					
	330	91.7	18					

DIMENSION FIGURE
尺寸图

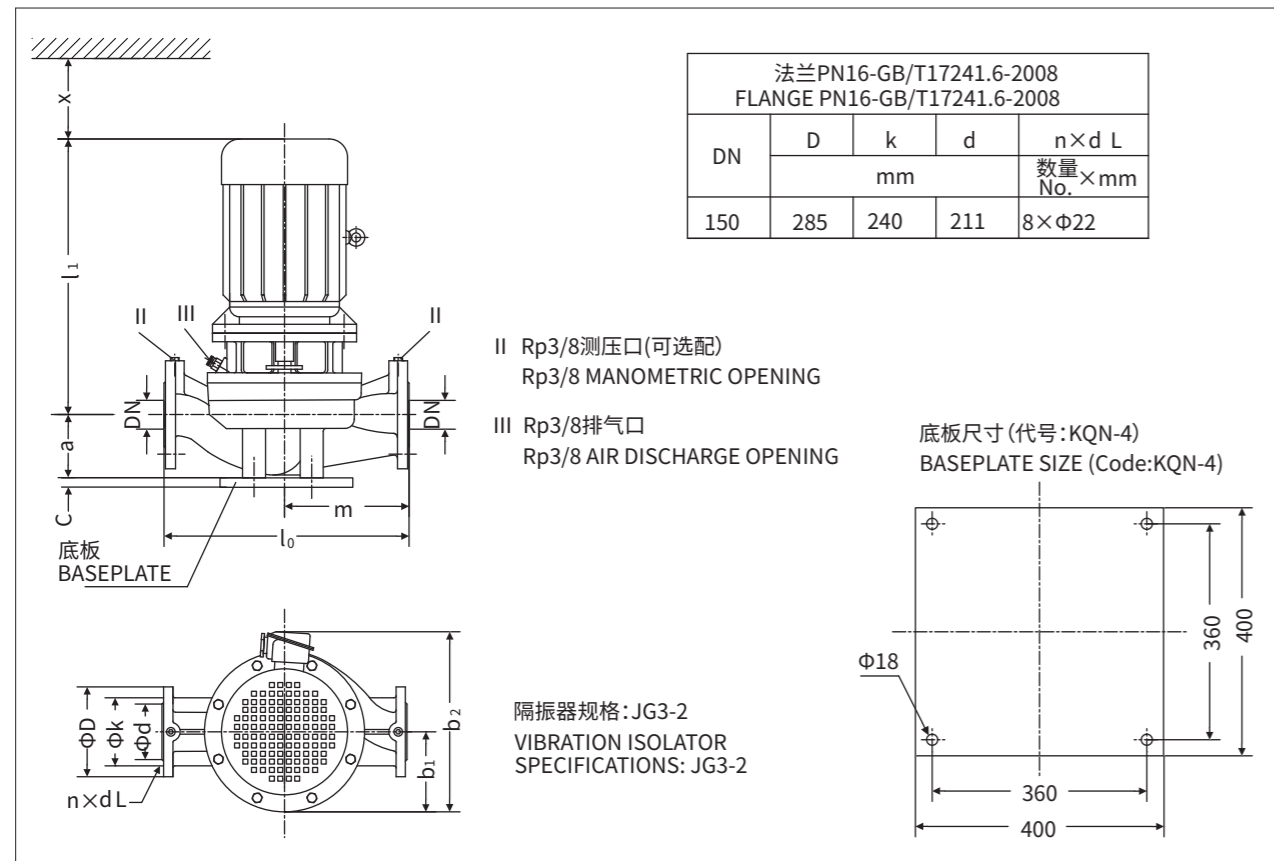

DIMENSION TABLE
KQL尺寸表

型号 TYPE	DN	l0	m	a	c	l1	b1	b2	x
		mm							
150KQL173-60-55/4	150	1050	500	280	37	965	315	680	165
150KQL187-70-75/4	150	1050	500	280	37	1030	360	760	165
150KQL200-80-75/4	150	1050	500	280	37	1030	360	760	165

DIMENSION FIGURE
尺寸图

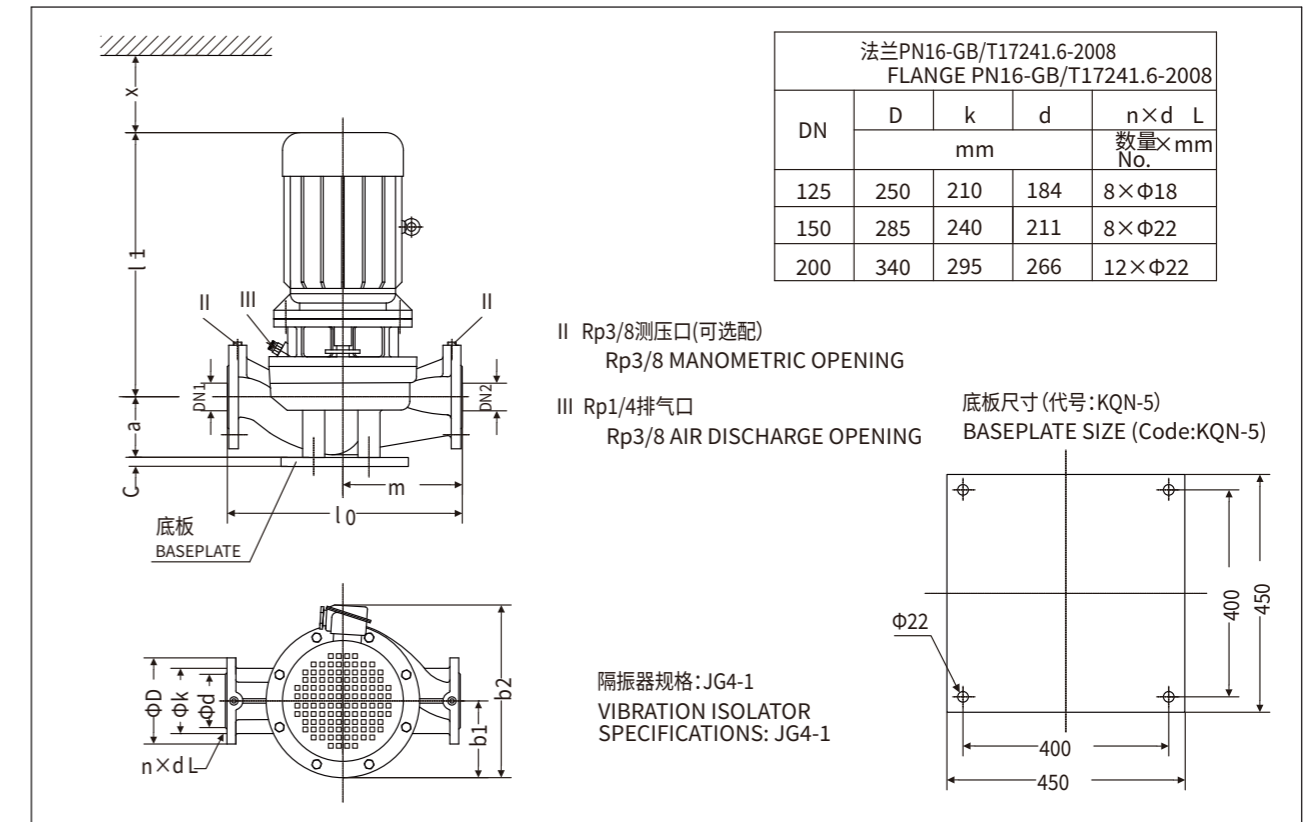

DIMENSION TABLE
KQL尺寸表

型号 TYPE	DN1	DN2	l0	m	a	c	l1	b1	b2	x
			mm							
200KQL280-10-11/4	200	200	990	480	275	37	751	250	495	150
200KQL300-12.5-15/4	200	200	990	480	275	37	781	250	495	150
200KQL280-16-18.5/4	200	200	990	480	275	37	823	250	530	150
200KQL300-20-22/4	200	200	990	480	275	37	873	250	530	150
150KQL187-70-55/2	150	125	820	370	240	37	965	275	640	150
150KQL200-80-75/2	150	125	820	370	240	37	1025	290	690	150
150KQL270-44-45/2	150	150	820	370	240	37	895	245	550	150
150KQL290-50-55/2	150	150	800	400	255	37	895	275	640	150
150KQL270-70-75/2	150	150	820	370	240	37	1025	290	690	150
150KQL290-80-90/2	150	150	820	370	240	37	1075	290	690	150

DIMENSION FIGURE
尺寸图

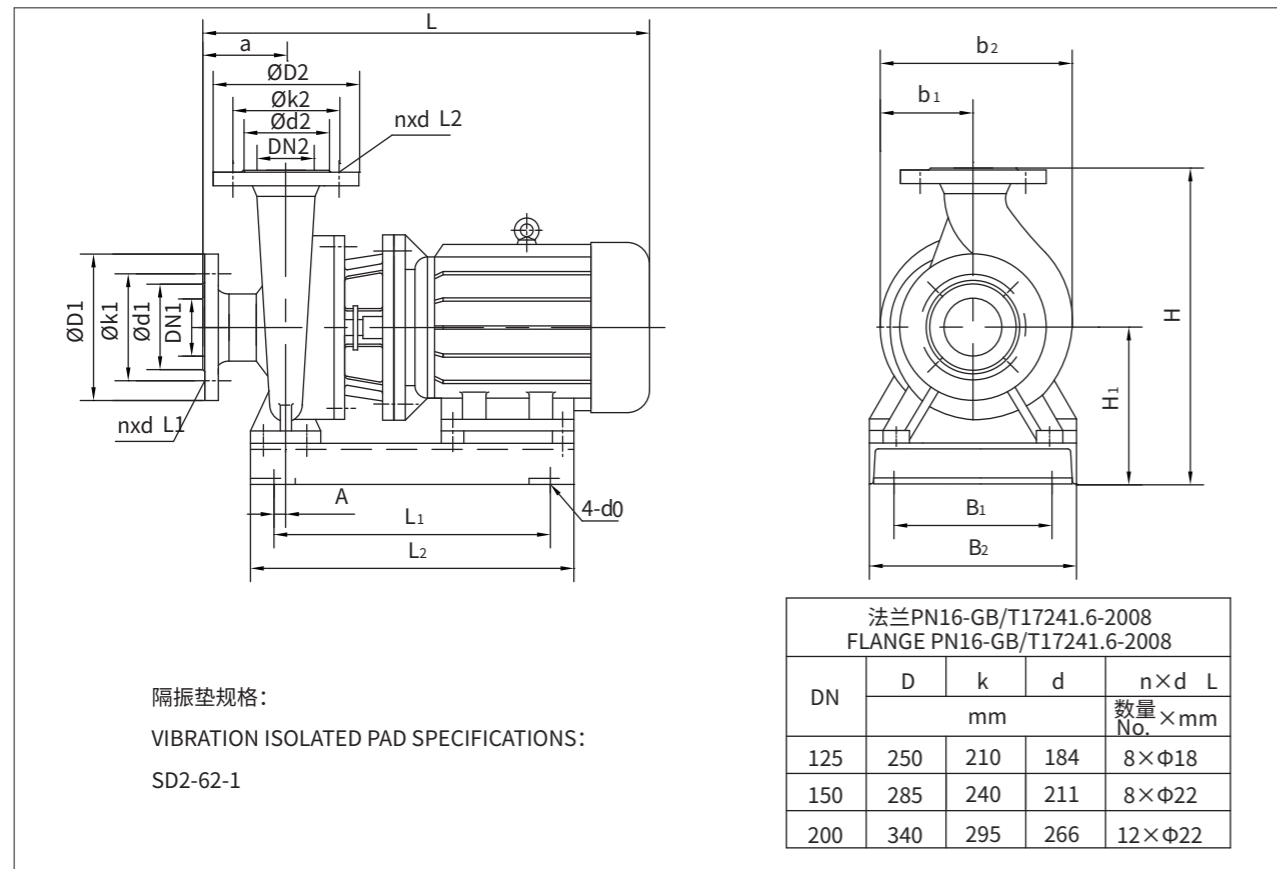

DIMENSION TABLE
KQW尺寸表

型号 TYPE	外形尺寸 Figure dimensions				安装尺寸 Installing dimensions								DN1	DN2
	L	H	b2	b1	4-φ0	a	L1	B1	L2	B2	H1	A		
150KQW173-60-55/4	1145	958	630	305	4-φ20	180	760	430	860	560	458	50	150	150
150KQW180-70-55/2	1080	744	550	275	4-φ20	125	730	370	830	500	374	30	150	125
150KQW187-70-75/4	1215	958	630	305	4-φ20	180	830	430	930	560	458	50	150	150
150KQW200-80-75/2	1150	753	550	275	4-φ20	125	800	430	900	560	383	30	150	125
150KQW200-80-75/4	1215	958	630	305	4-φ20	180	830	430	930	560	458	50	150	150
150KQW270-44-45/2	980	702	400	200	4-φ15	125	635	300	735	400	332	30	150	125
150KQW290-50-55/2	1075	719	420	195	4-φ20	125	730	370	830	500	349	25	150	125
150KQW270-70-75/2	1145	753	550	275	4-φ20	125	800	430	900	560	383	30	150	125
150KQW290-80-90/2	1145	753	550	275	4-φ20	125	850	430	950	560	383	30	150	125
200KQW280-10-11/4	900	862	534	255	4-φ20	160	580	370	680	510	382	50	200	200
200KQW300-12.5-15/4	930	862	534	255	4-φ20	160	580	370	680	510	382	50	200	200
200KQW280-16-18.5/4	970	862	534	255	4-φ20	160	580	370	680	510	382	50	200	200
200KQW300-20-22/4	1020	862	529	250	4-φ20	160	615	370	715	510	382	50	200	200

CHARACTERISTIC CURVE
性能曲线

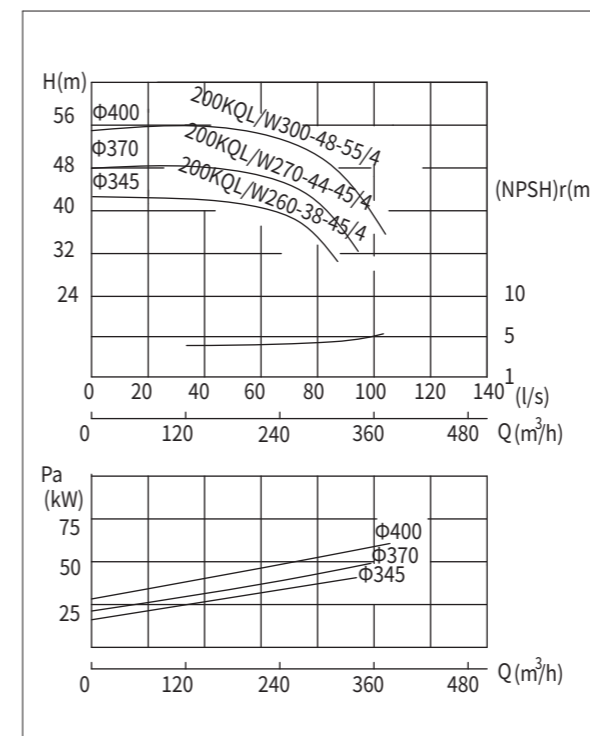
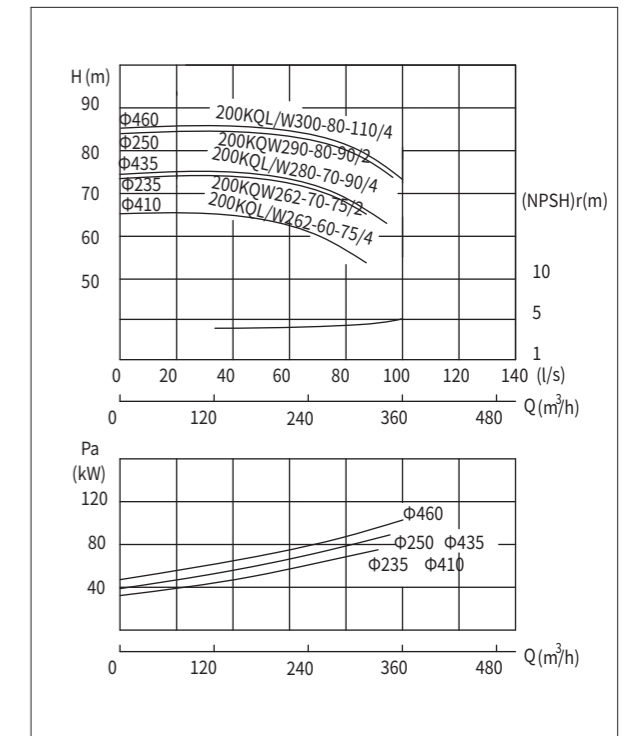
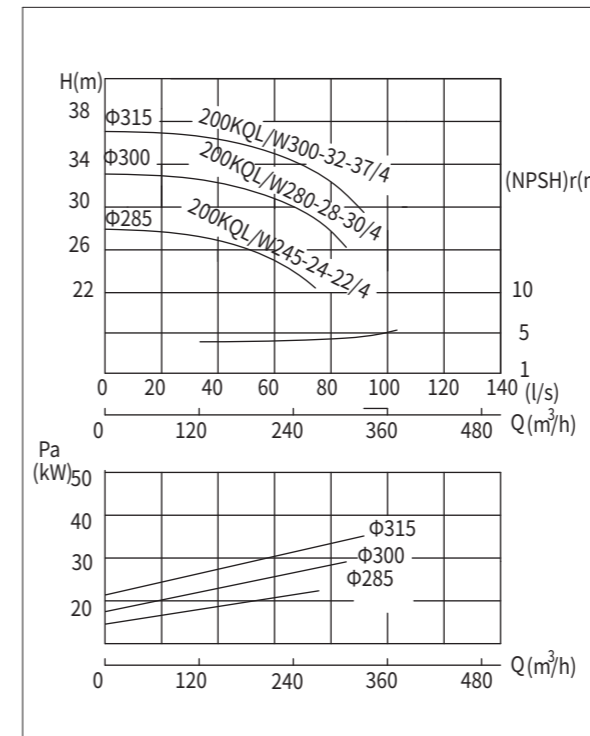

PERFORMANCE DATA
参数表

型号 TYPE	流量 Capacity		扬程 Head (m)	转速 Speed (r/min)	效率 Efficiency (%)	电机 功率 Power (kW)	必需 汽蚀 余量 (NPSH)r (m)	重量 Weight (kg)
	(m ³ /h)	(l/s)						
200KQL/W245-24-22/4	171	47.5	25.4	1480	82	22	4	455
	245	72.2	24					
	270	75.0	21.6					
200KQL/W280-28-30/4	196	54.4	30.6	1480	82	30	4	520
	280	77.8	28					
	308	85.6	26.2					
200KQL/W300-32-37/4	210	58.3	34.5	1480	83.8	37	4	615
	300	83.3	32					
	330	91.7	29.5					
200KQL/W260-38-45/4	182	50.6	41.4	1480	78	45	4	575
	260	72.2	38					
	312	86.7	29.6					
200KQL/W270-44-45/4	189	52.5	46.2	1480	80	45	4	648
	270	75.0	44					
	297	82.5	39.6					
200KQL/W300-48-55/4	210	58.3	50.4	1480	81.6	55	4	745
	300	83.3	48					
	330	91.7	43.2					
200KQL/W262-60-75/4	182	50.6	64	1480	67	75	4.5	888
	262	72.8	60					
	312	86.7	54					
200KQW262-70-75/2	182	50.6	78	2960	78	75	8	790
	262	72.8	70					
	312	86.7	65					
200KQL/W280-70-90/4	196	54.4	74	1480	69	90	4.5	986
	280	77.8	70					
	336	93.3	64					
200KQW290-80-90/2	203	56.4	92	2960	80	90	8	850
	290	80.6	80					
	348	96.7	69					
200KQL/W300-80-110/4	210	58.3	85	1480	70	110	4.5	1308
	300	83.3	80					
	360	100.0	73					

DIMENSION FIGURE
尺寸图

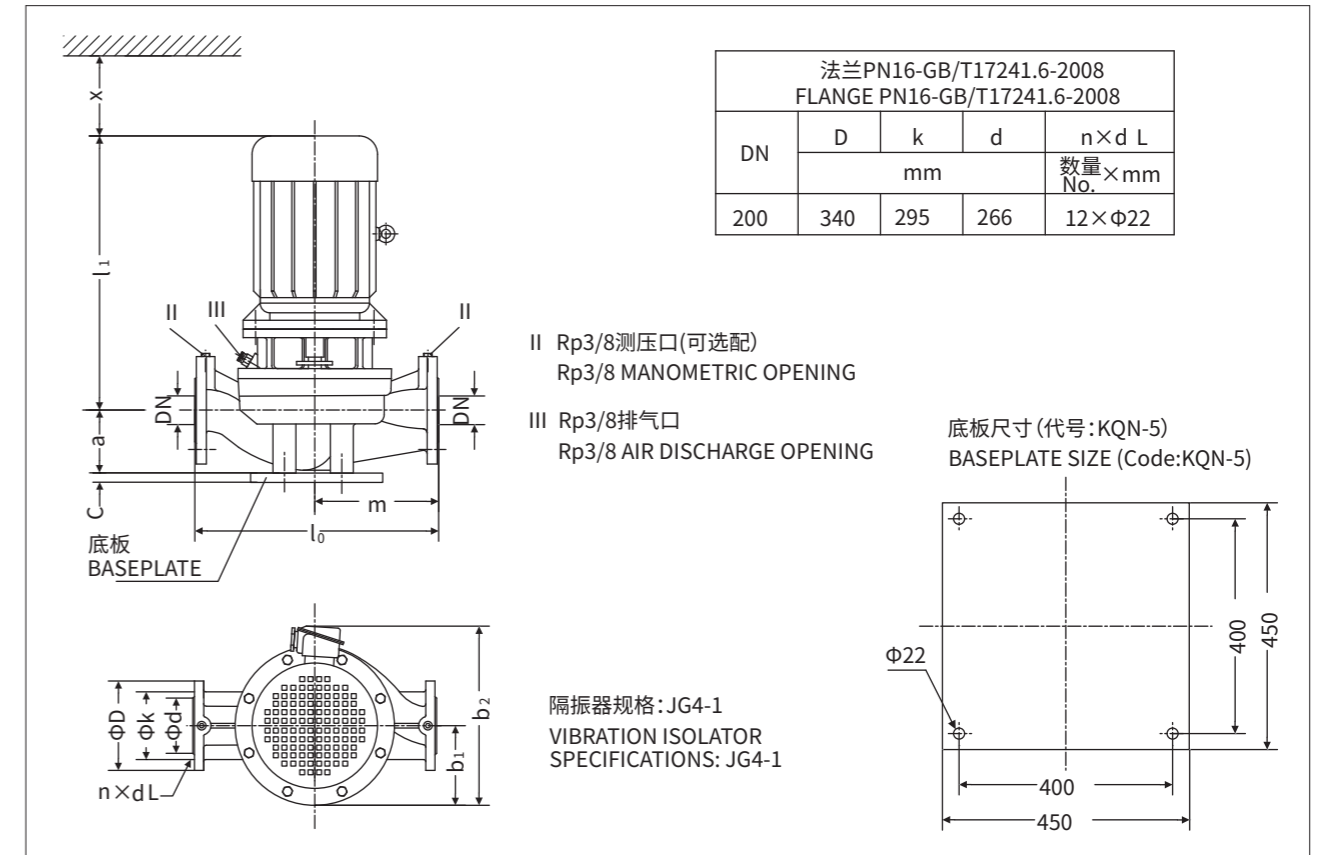

DIMENSION TABLE
KQL尺寸表

型号 TYPE	DN	l ₀	m	a	c	l ₁	b ₁	b ₂	x
		mm							
200KQL245-24-22/4	200	1000	500	295	37	876	250	540	155
200KQL280-28-30/4	200	1000	500	295	37	876	270	610	155
200KQL300-32-37/4	200	1000	500	295	37	886	295	625	155
200KQL260-38-45/4	200	1070	535	280	37	914	295	625	155
200KQL270-44-45/4	200	1070	535	280	37	915	315	680	155
200KQL300-48-55/4	200	1070	535	280	37	976	360	760	155
200KQL262-60-75/4	200	1170	560	320	37	1035	360	760	165
200KQL280-70-90/4	200	1170	560	320	37	1096	360	760	165
200KQL300-80-110/4	200	1170	560	320	37	1350	450	980	165

DIMENSION FIGURE
尺寸图

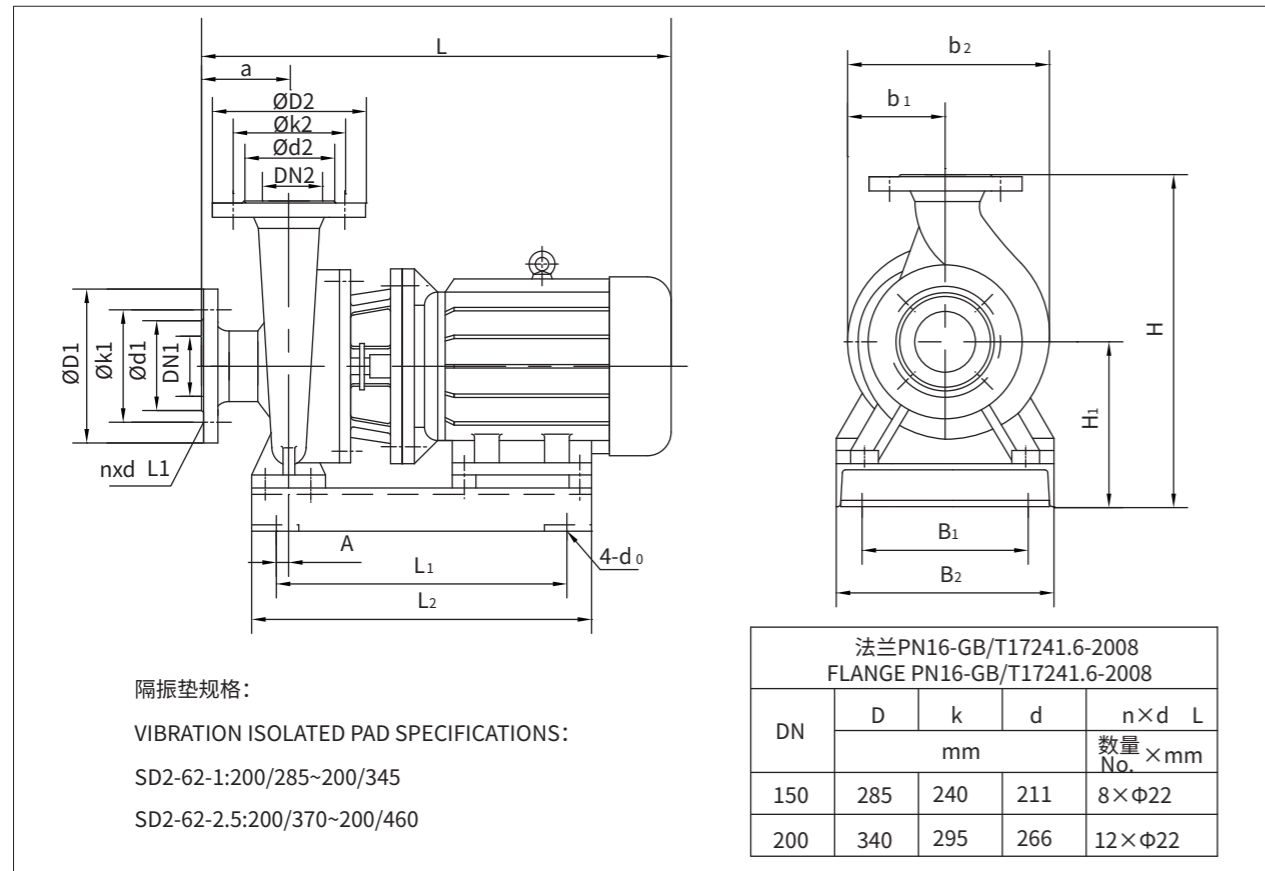

DIMENSION TABLE
KQW尺寸表

型号 TYPE	外形尺寸 Figure dimensions				安装尺寸 Installing dimensions								DN1	DN2
	L	H	b2	b1	4-d0	a	L1	B1	L2	B2	H1	A		
200KQW245-24-22/4	1030	918	529	250	4-φ20	160	670	430	770	560	418	50	200	200
200KQW280-28-30/4	1030	918	590	280	4-φ20	160	670	430	770	560	418	50	200	200
200KQW300-32-37/4	1040	918	590	280	4-φ20	160	670	430	770	560	418	50	200	200
200KQW260-38-45/4	1065	878	577	280	4-φ20	160	695	430	795	560	418	50	200	200
200KQW270-44-45/4	1065	878	577	280	4-φ20	160	695	430	795	560	418	50	200	200
200KQW300-48-55/4	1125	878	572	280	4-φ20	160	760	430	860	560	418	50	200	200
200KQW262-60-75/4	1225	1022	673	320	4-φ25	180	830	480	930	640	462	50	200	200
200KQW262-70-75/2	1195	825	550	275	4-φ20	170	790	430	919	560	445	30	200	150
200KQW280-70-90/4	1265	1022	673	320	4-φ25	180	880	480	980	640	462	50	200	200
200KQW290-80-90/2	1245	825	580	275	4-φ20	170	840	430	970	560	445	30	200	150
200KQW300-80-110/4	1530	1022	683	330	4-φ25	180	955	480	1055	640	462	50	200	200

CHARACTERISTIC CURVE
性能曲线

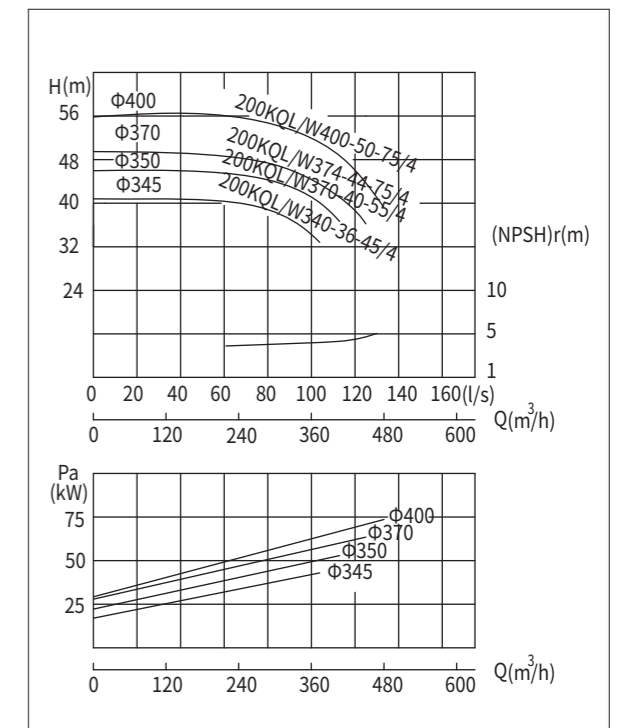
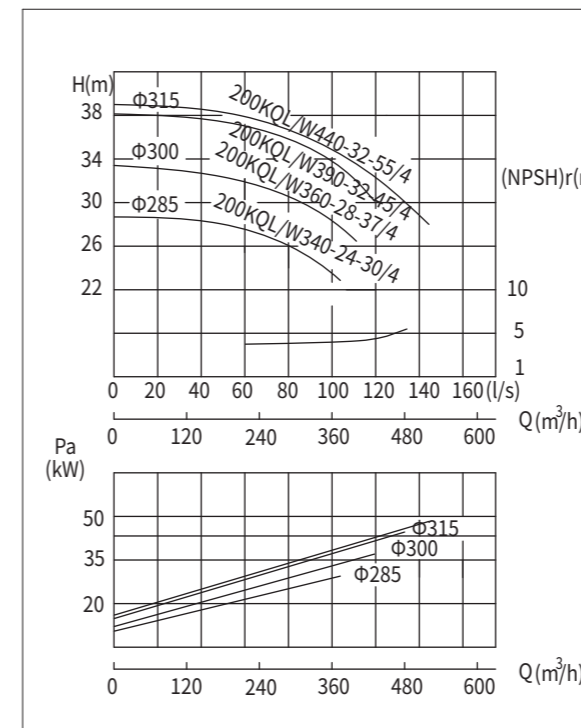
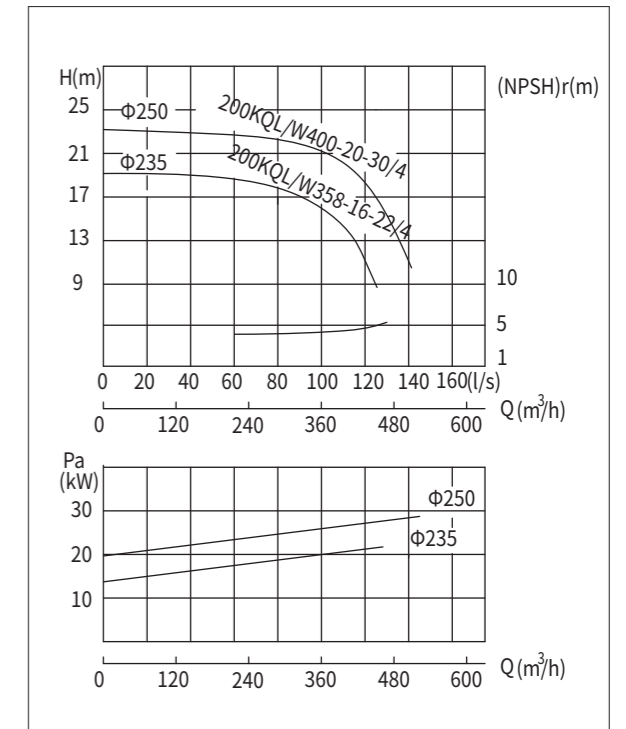
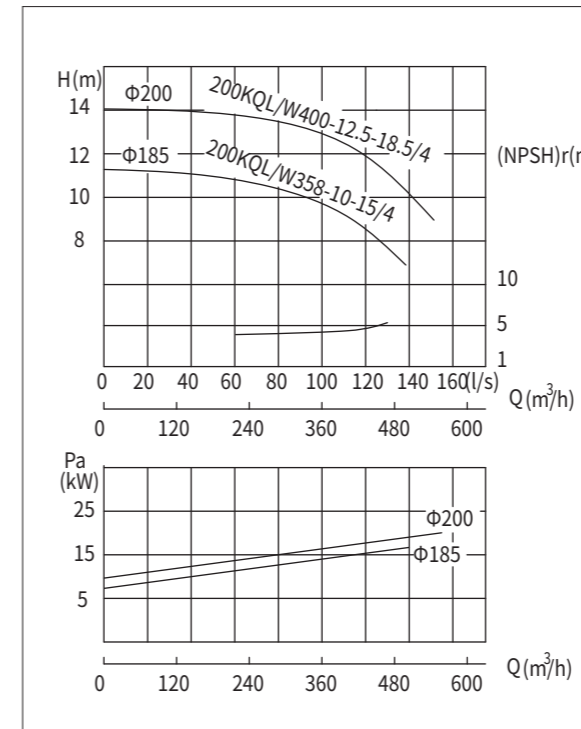

PERFORMANCE DATA
参数表

型号 TYPE	流量 Capacity		扬程 Head (m)	转速 Speed (r/min)	效率 Efficiency (%)	电机 功率 Power (kW)	必需 汽蚀 余量 (NPSH)r (m)	重量 Weight (kg)
	(m ³ /h)	(l/s)						
200KQL/W358-10-15/4	250	69.4	13	1480	81	15	4	346
	358	99.4	10					
	394	109.4	7					
200KQL/W400-12.5-18.5/4	280	77.8	15.5	1480	82	18.5	4	380
	400	111.1	12.5					
	440	122.2	10.2					
200KQL/W358-16-22/4	250	69.4	18	1480	83	22	4	586
	358	99.4	16					
	430	119.4	11.2					
200KQL/W400-20-30/4	280	77.8	23	1480	84	30	4	454
	400	111.1	20					
	480	133.3	14					
200KQL/W340-24-30/4	238	66.1	25.2	1480	80	30	4	510
	340	96.1	24					
	374	103.9	21.6					
200KQL/W360-28-37/4	252	70.0	31.5	1480	81	37	4	560
	360	100.0	28					
	396	110.0	25					
200KQL/W390-32-45/4	273	75.8	34.5	1480	83.9	45	4	600
	390	108.3	32					
	429	119.2	28.8					
200KQL/W440-32-55/4	308	85.6	37	1480	82	55	4.5	708
	440	122.2	32					
	520	144.4	28					
200KQL/W340-36-45/4	238	66.1	39	1480	80	45	4	605
	340	96.1	36					
	374	103.9	32.4					
200KQL/W370-40-55/4	259	71.9	45.5	1480	82	55	4	712
	370	102.8	40					
	407	113.1	36					
200KQL/W374-44-75/4	262	72.8	48	1480	81	75	4	828
	374	103.9	44					
	449	124.7	34					
200KQL/W400-50-75/4	280	77.8	54.5	1480	82.6	75	4	819
	400	111.1	50					
	480	133.3	39					

DIMENSION FIGURE
尺寸图

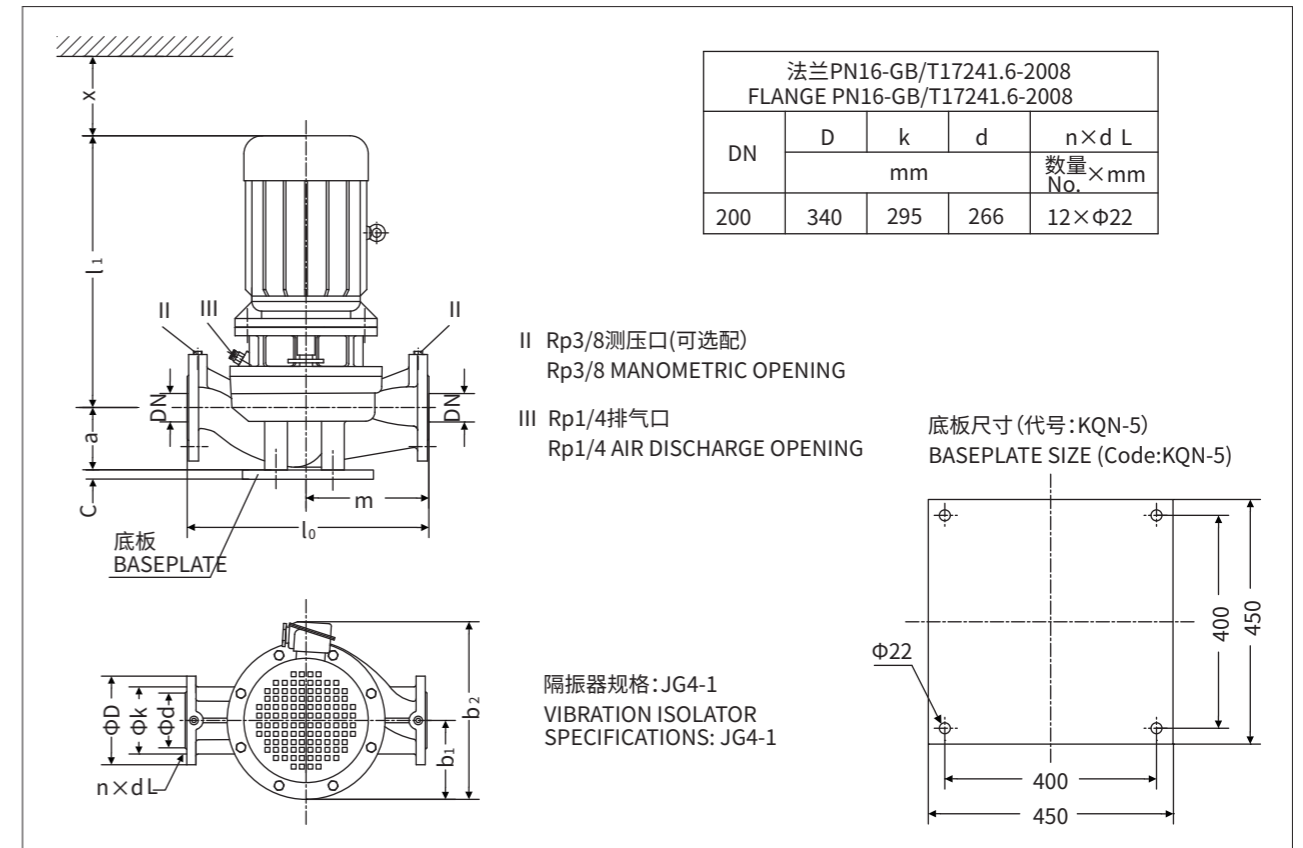

DIMENSION TABLE
KQL尺寸表

型号 TYPE	DN	l ₀	m	a	c	l ₁	b ₁	b ₂	x
mm									
200KQL358-10-15/4	200	990	480	275	37	781	250	530	150
200KQL400-12.5-18.5/4	200	990	480	275	37	823	250	530	150
200KQL358-16-22/4	200	990	480	275	37	873	250	530	150
200KQL400-20-30/4	200	990	480	275	37	873	270	575	150
200KQL340-24-30/4 200KQL360-28-37/4	200	1000	500	295	37	876	270	575	155
	200	1000	500	295	37	886	295	625	155
200KQL390-32-45/4	200	1000	500	295	37	911	295	625	155
200KQL440-32-55/4	200	1000	500	295	37	985	315	680	155
200KQL340-36-45/4	200	1070	535	280	37	914	295	625	155
200KQL370-40-55/4	200	1070	535	280	37	976	315	680	155
200KQL374-44-75/4	200	1070	535	280	37	1035	360	760	155
200KQL400-50-75/4	200	1070	535	280	37	1035	360	760	155

DIMENSION FIGURE
尺寸图

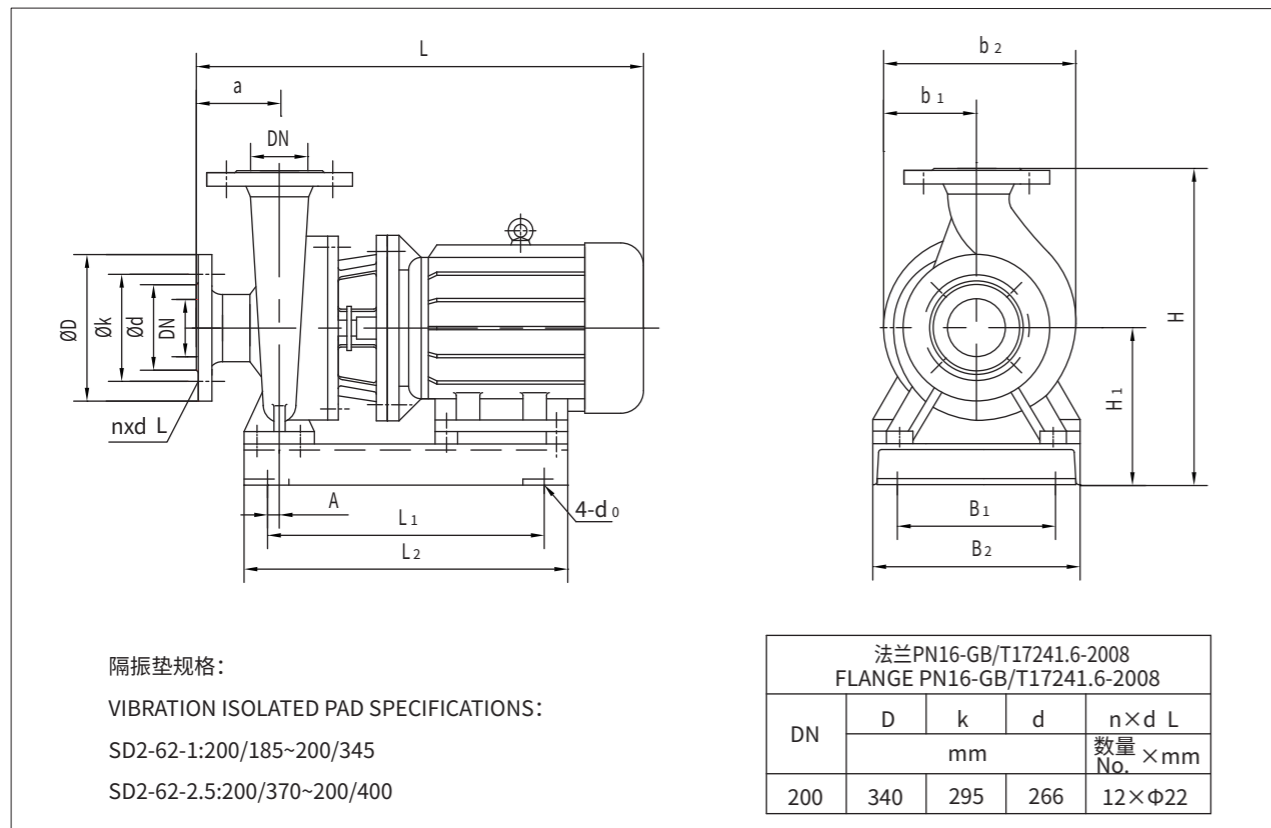

DIMENSION TABLE
KQW尺寸表

型号 TYPE	外形尺寸 Figure dimensions				安装尺寸 Installing dimensions								DN1
	L	H	b ₂	b ₁	4-d ₀	a	L ₁	B ₁	L ₂	B ₂	H ₁	A	
200KQW358-10-15/4	930	862	529	250	4-φ20	160	580	370	680	510	382	50	200
200KQW400-12.5-18.5/4	970	862	529	250	4-φ20	160	580	370	680	510	382	50	200
200KQW358-16-22/4	1020	862	529	250	4-φ20	160	615	370	715	510	382	50	200
200KQW400-20-30/4	1030	859	529	250	4-φ20	160	665	370	765	500	379	50	200
200KQW340-24-30/4	1030	918	572	280	4-φ20	160	670	430	770	560	418	50	200
200KQW360-28-37/4	1040	918	572	280	4-φ20	160	670	430	770	560	418	50	200
200KQW390-32-45/4	1065	918	572	280	4-φ20	160	695	430	795	560	418	50	200
200KQW440-32-55/4	1120	918	572	280	4-φ20	160	760	430	860	560	418	50	200
200KQW340-36-45/4	1065	878	572	280	4-φ20	160	695	430	795	560	418	50	200
200KQW370-40-55/4	1125	878	572	280	4-φ20	160	760	430	860	560	418	50	200
200KQW374-44-75/4	1205	878	587	290	4-φ20	160	830	430	930	560	418	50	200
200KQW400-50-75/4	1205	878	587	290	4-φ20	160	830	430	930	560	418	50	200

CHARACTERISTIC CURVE
性能曲线

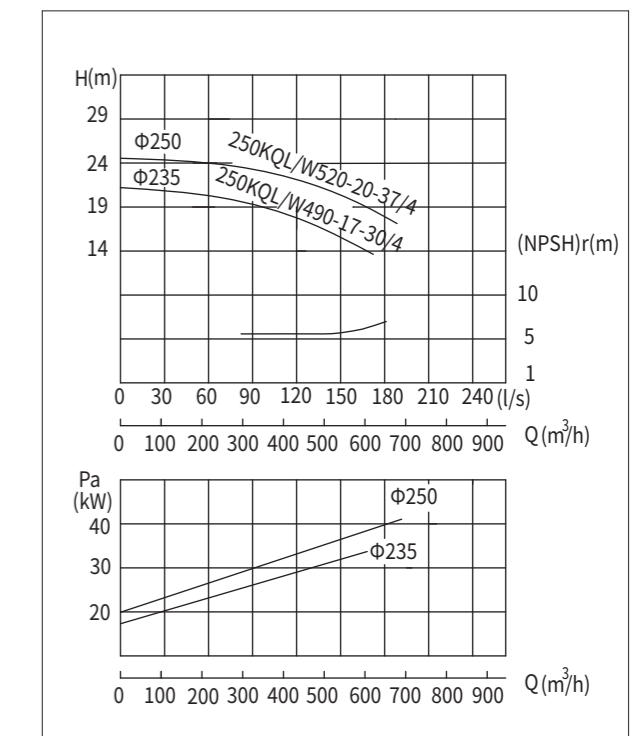
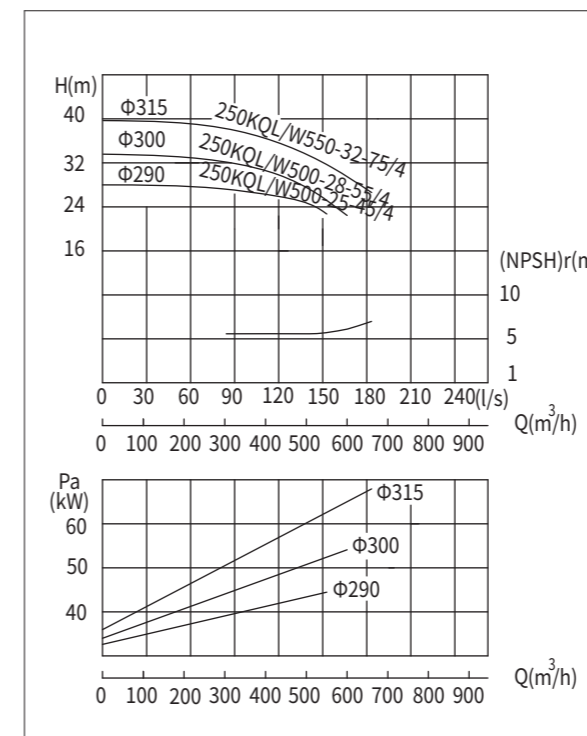
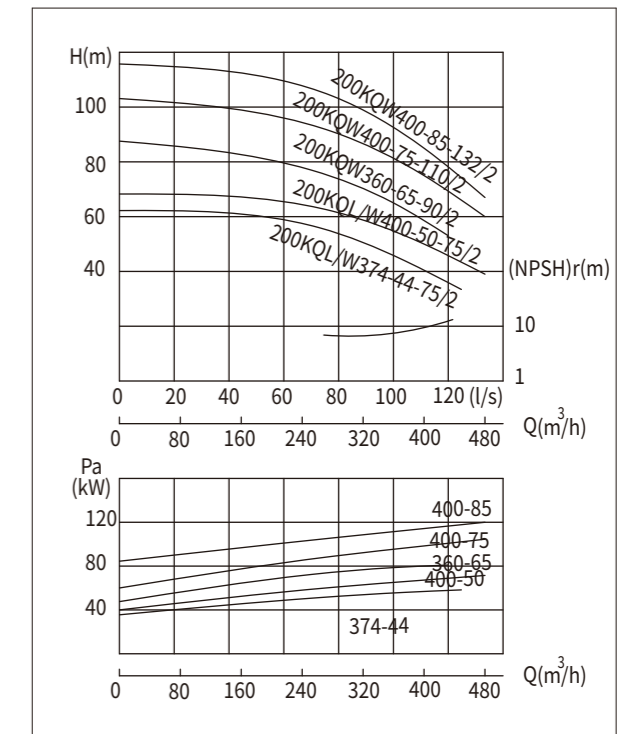
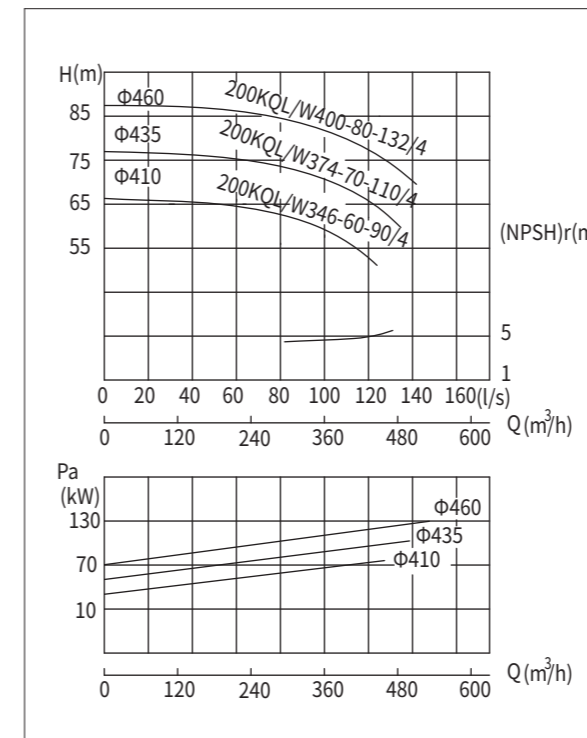

PERFORMANCE DATA
参数表

型号 TYPE	流量 Capacity		扬程 Head (m)	转速 Speed (r/min)	效率 Efficiency (%)	电机 功率 Power (kW)	必需 汽蚀 余量 (NPSH) _r (m)	重量 Weight (kg)
	(m ³ /h)	(l/s)						
200KQL/W346-60-90/4	242	67.2	64	1480	75	90	4.5	935
	346	96.1	60					
	415	115.3	54					
200KQL/W374-70-110/4	262	72.8	74	1480	77	110	4.5	1276
	374	103.9	70					
	449	124.7	64					
200KQL/W400-80-132/4	280	77.8	85	1480	78.5	132	4.5	1380
	400	111.1	80					
	480	133.3	73					
200KQL/W374-44-75/2	262	72.8	53	2960	80	75	9	840
	374	103.9	44					
	449	124.7	33					
200KQL/W400-50-75/2	280	77.8	62	2960	81	75	9	840
	400	111.1	50					
	480	133.3	39					
200KQW360-65-90/2	252	70.0	77	2960	81	90	8	840
	360	100.0	65					
	432	120.0	53					
200KQW400-75-110/2	280	77.8	91	2960	83	110	8	1100
	400	111.1	75					
	480	133.3	65					
200KQW400-85-132/2	280	77.8	104	2960	81	132	8	1225
	400	111.1	85					
	480	133.3	67					
250KQL/W520-20-37/4	364	101.1	22	1480	84.5	37	5.5	630
	520	144.4	20					
	600	166.7	17					
250KQL/W500-25-45/4	350	97.2	26.2	1480	84.7	45	5.5	622
	500	138.9	25					
	600	166.7	21					
250KQL/W500-28-55/4	364	101.1	31.5	1480	83	55	5.5	716
	500	138.9	28					
	600	166.7	25					
250KQL/W550-32-75/4	400	111.1	33.5	1480	85	75	5.5	852
	550	152.8	32					
	660	183.3	29					

DIMENSION FIGURE
尺寸图

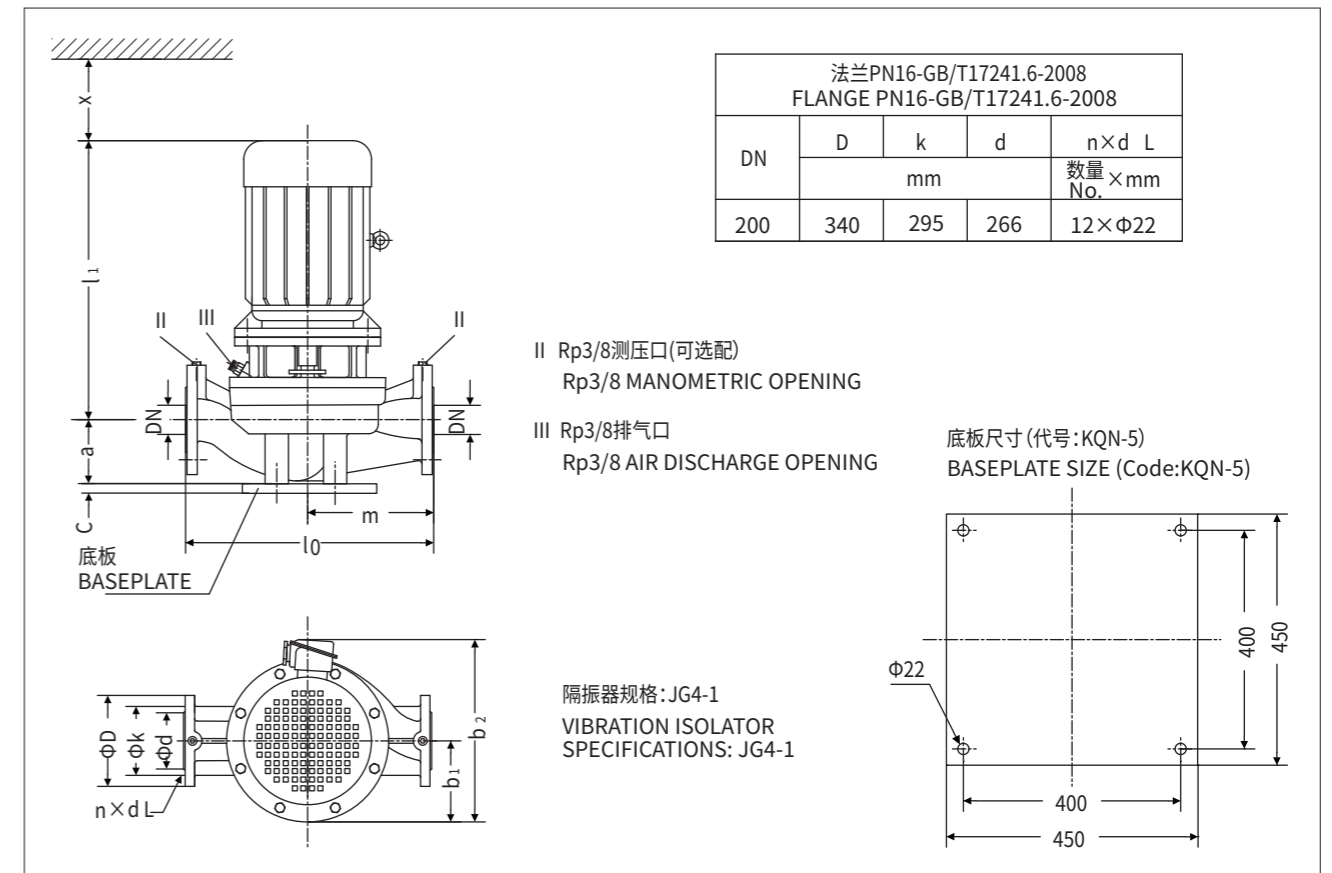

DIMENSION TABLE
KQL尺寸表

型号 TYPE	DN	l ₀	m	a	c	l ₁	b ₁	b ₂	x
200KQL346-60-90/4	200	1170	560	320	37	1096	360	760	165
200KQL374-70-110/4	200	1170	560	320	37	1350	450	980	165
200KQL400-80-132/4	200	1170	560	320	37	1371	450	980	165

DIMENSION FIGURE
尺寸图

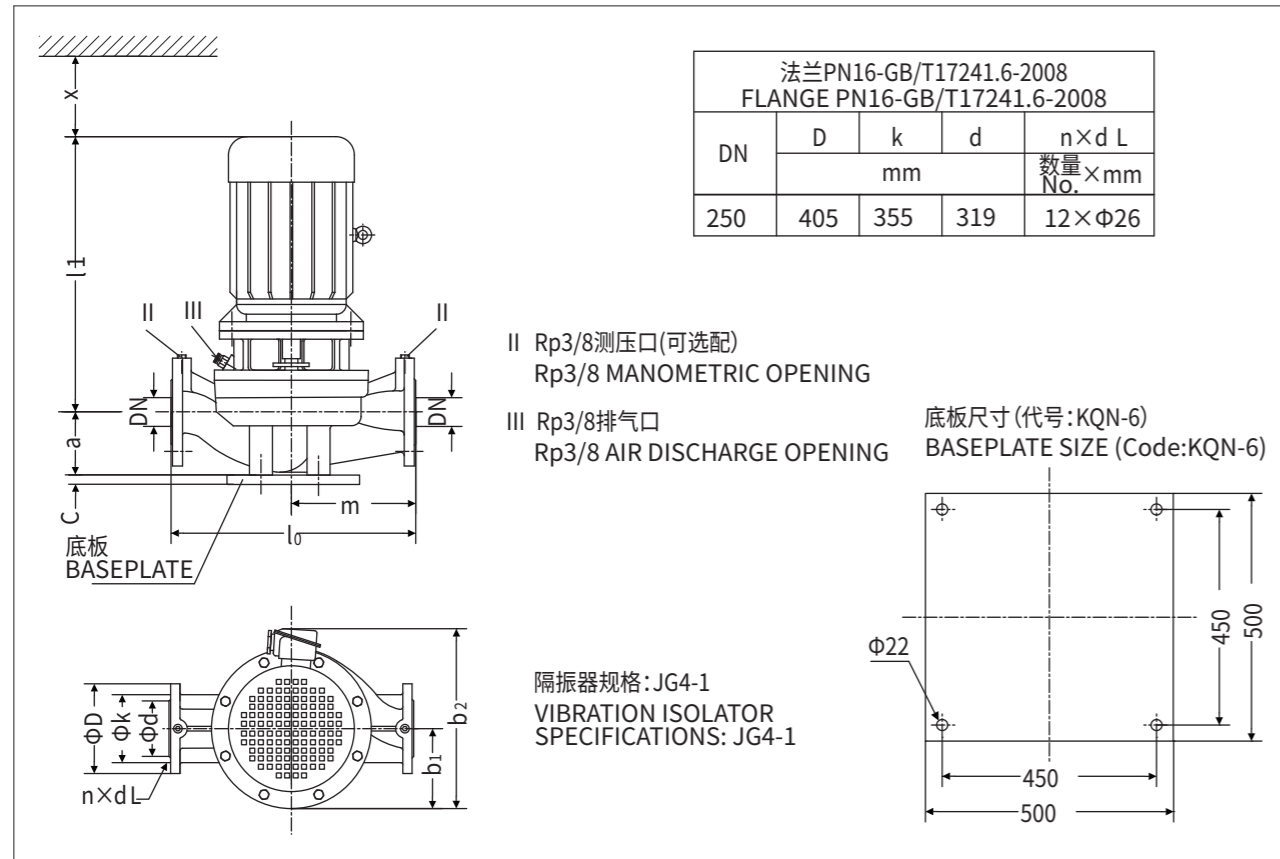

DIMENSION TABLE
KQL尺寸表

型号 TYPE	DN	l ₀	m	a	c	l ₁	b ₁	b ₂	x
		mm							
200KQL374-44-75/2	200	850	400	290	40	1075	290	690	150
200KQL400-50-75/2	200	850	400	290	40	1075	290	690	150
250KQL490-17-30/4	250	1100	550	335	40	864	295	660	180
250KQL520-20-37/4	250	1100	550	335	40	870	295	660	180
250KQL500-25-45/4	250	1100	550	335	40	915	295	660	180
250KQL500-28-55/4	250	1100	550	335	40	959	360	660	180
250KQL550-32-75/4	250	1100	550	335	40	1039	360	760	180

DIMENSION FIGURE
尺寸图

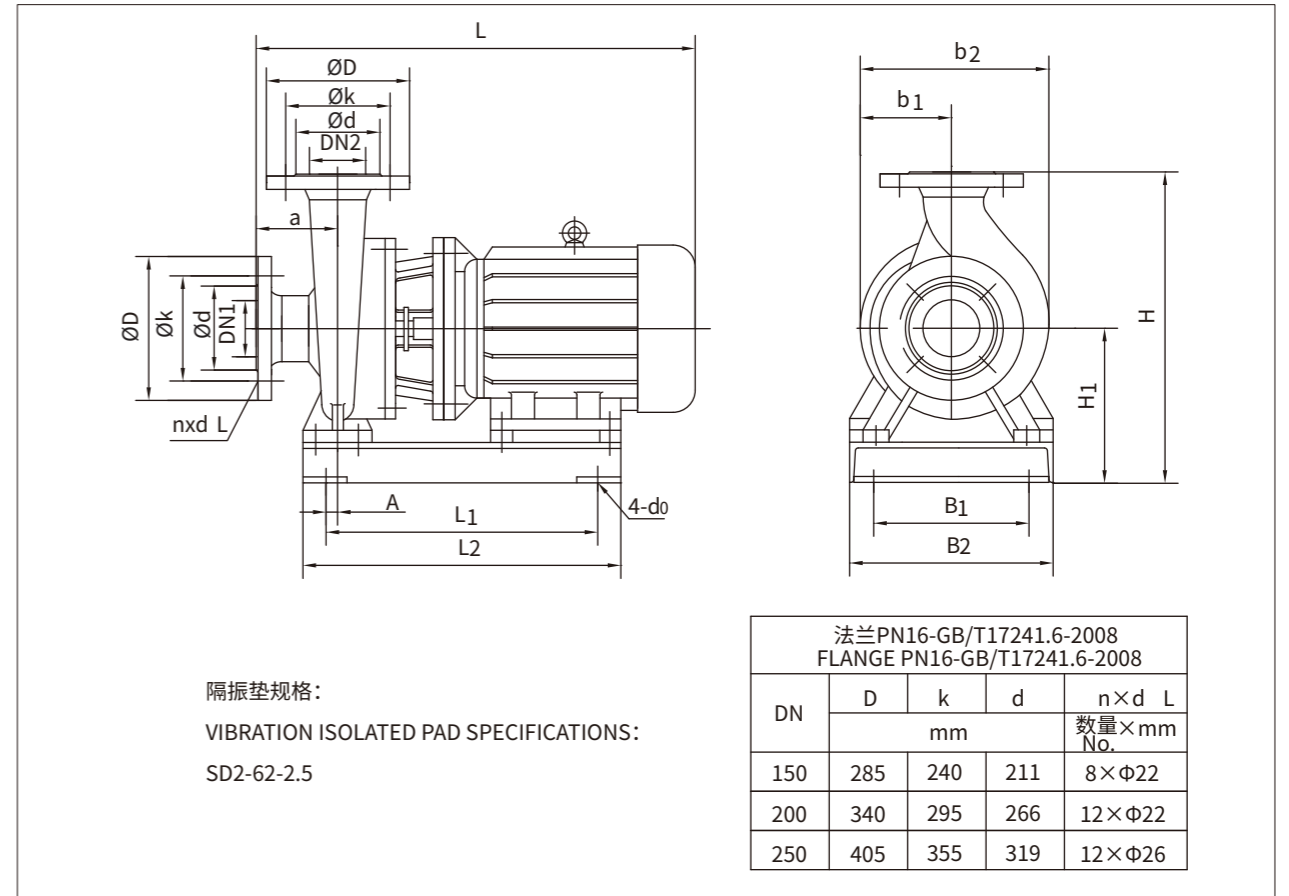

DIMENSION TABLE
KQW尺寸表

型号 TYPE	外形尺寸 Figure dimensions				安装尺寸 Installing dimensions							DN1	DN2	
	L	H	b ₂	b ₁	4-d ₀	a	L ₁	B ₁	L ₂	B ₂	H ₁			A
200KQW346-60-90/4	1265	1022	661	320	4-Φ25	180	880	480	980	640	462	50	200	200
200KQW374-70-110/4	1530	1022	683	330	4-Φ25	180	955	480	1055	640	462	50	200	200
200KQW400-80-132/4	1560	1022	683	330	4-Φ25	180	1005	480	1150	640	462	50	200	200
200KQW374-44-75/2	1190	845	550	275	4-Φ20	170	790	430	919	560	445	30	200	150
200KQW400-50-75/2	1190	845	550	275	4-Φ20	170	790	430	919	560	445	30	200	150
200KQW360-65-90/2	1240	845	550	275	4-Φ20	170	840	430	940	560	445	30	200	150
200KQW400-75-110/2	1385	825	660	330	4-Φ25	170	872	540	1002	640	445	30	200	150
200KQW400-85-132/2	1485	825	660	330	4-Φ25	170	912	540	1082	640	445	30	200	150
250KQW490-17-30/4	1074	989	690	300	4-Φ20	200	630	500	795	640	441	30	250	250
250KQW520-20-37/4	1084	989	690	300	4-Φ20	200	630	500	780	640	439	30	250	250
250KQW500-25-45/4	1109	989	690	320	4-Φ20	200	630	500	805	640	439	30	250	250
250KQW500-28-55/4	1169	989	660	320	4-Φ20	200	630	500	880	640	439	30	250	250
250KQW550-32-75/4	1245	989	660	320	4-Φ20	200	710	500	935	640	439	30	250	250

CHARACTERISTIC CURVE
性能曲线

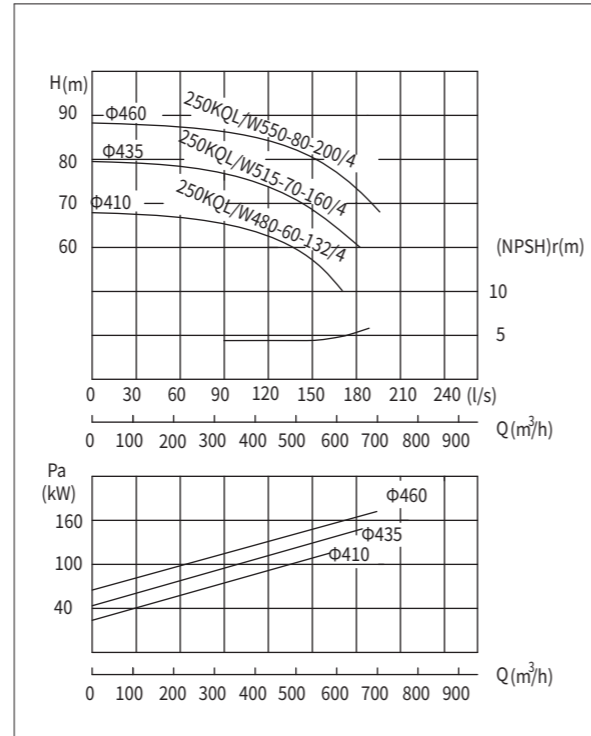
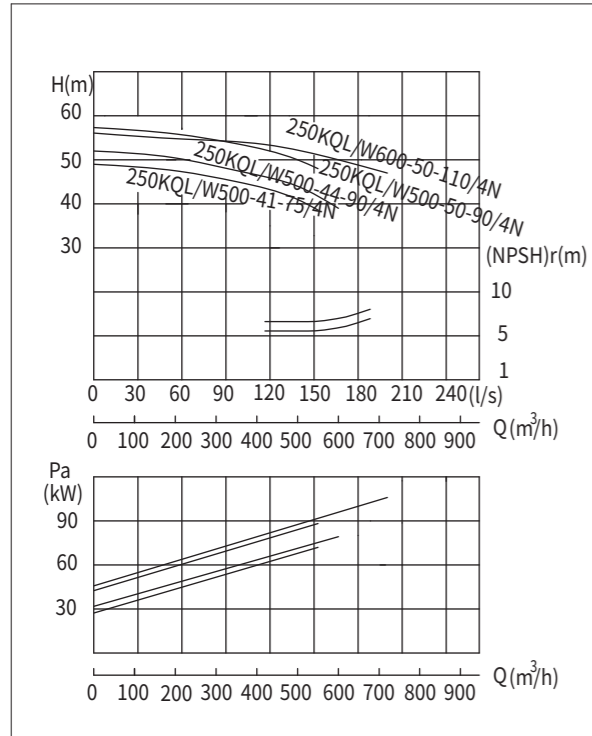

PERFORMANCE DATA
参数表

型号 TYPE	流量 Capacity		扬程 Head (m)	转速 Speed (r/min)	效率 Efficiency (%)	电机 功率 Power (kW)	必需 汽蚀 余量 (NPSH)r (m)	重量 Weight (kg)
	(m³/h)	(l/s)						
250KQL500-41-75/4N 250KQW500-41-75/4N	350	97.2	44	1480	83	75	7 5.5	980
	500	138.9	41					
	550	152.8	39					
250KQL500-44-90/4N 250KQW500-44-90/4N	365	101.4	46	1480	80	90	7 5.5	1050
	500	138.9	44					
	600	166.7	39					
250KQL500-50-90/4N 250KQW500-50-90/4N	350	97.2	53	1480	84.1	90	7 5.5	1050
	500	138.9	50					
	550	152.8	48					
250KQL600-50-110/4N 250KQW600-50-110/4N	420	116.7	53.5	1480	83	110	7 5	1306
	600	166.7	50					
	720	200.0	47					
250KQL/W480-60-132/4	350	97.2	64	1480	79	132	4.5	1492
	480	133.3	60					
	580	161.1	52.5					
250KQL/W515-70-160/4	375	104.2	74	1480	80	160	4.5	1510
	515	143.0	70					
	620	172.2	61.2					
250KQL/W550-80-200/4	400	111.1	85	1480	81.6	200	4.5	1697
	550	152.8	80					
	660	183.3	73					

DIMENSION FIGURE
尺寸图

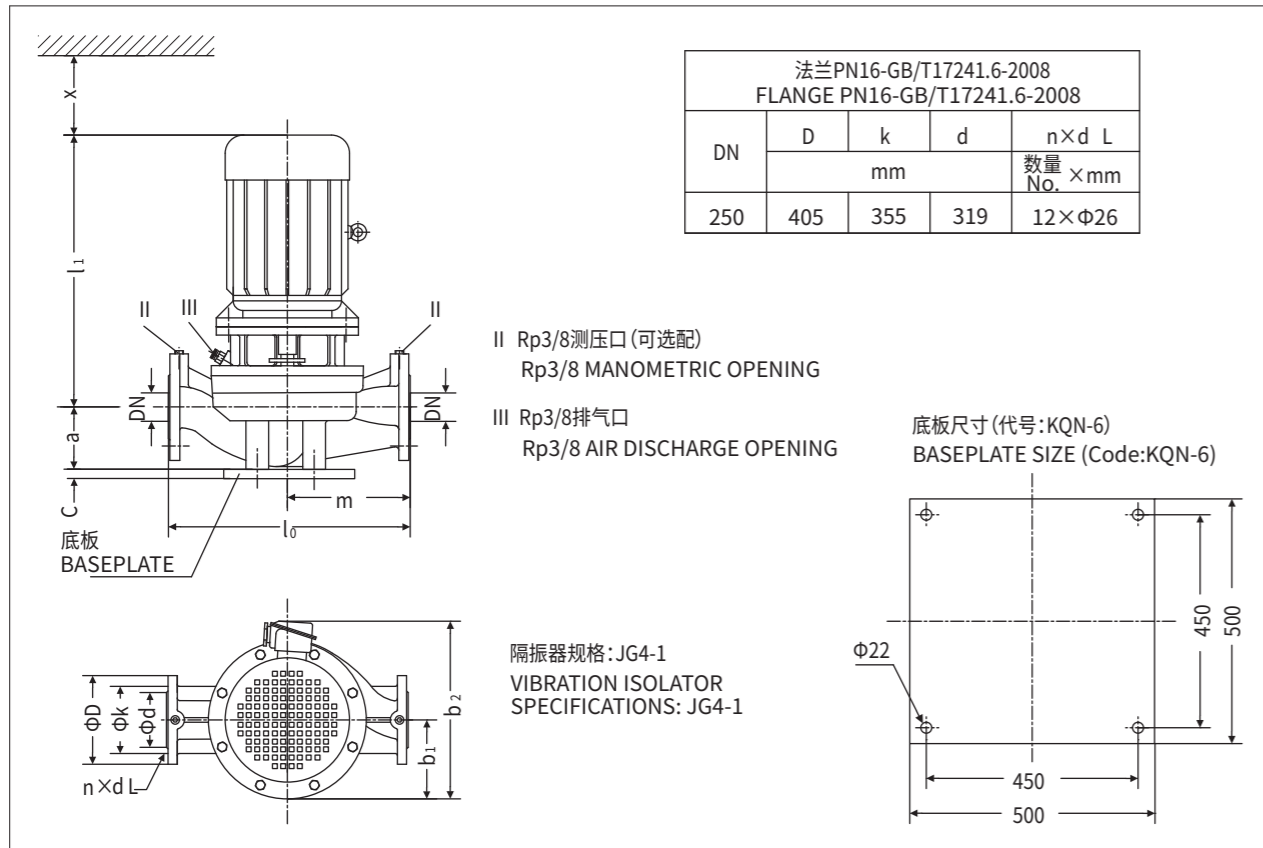

DIMENSION FIGURE
尺寸图

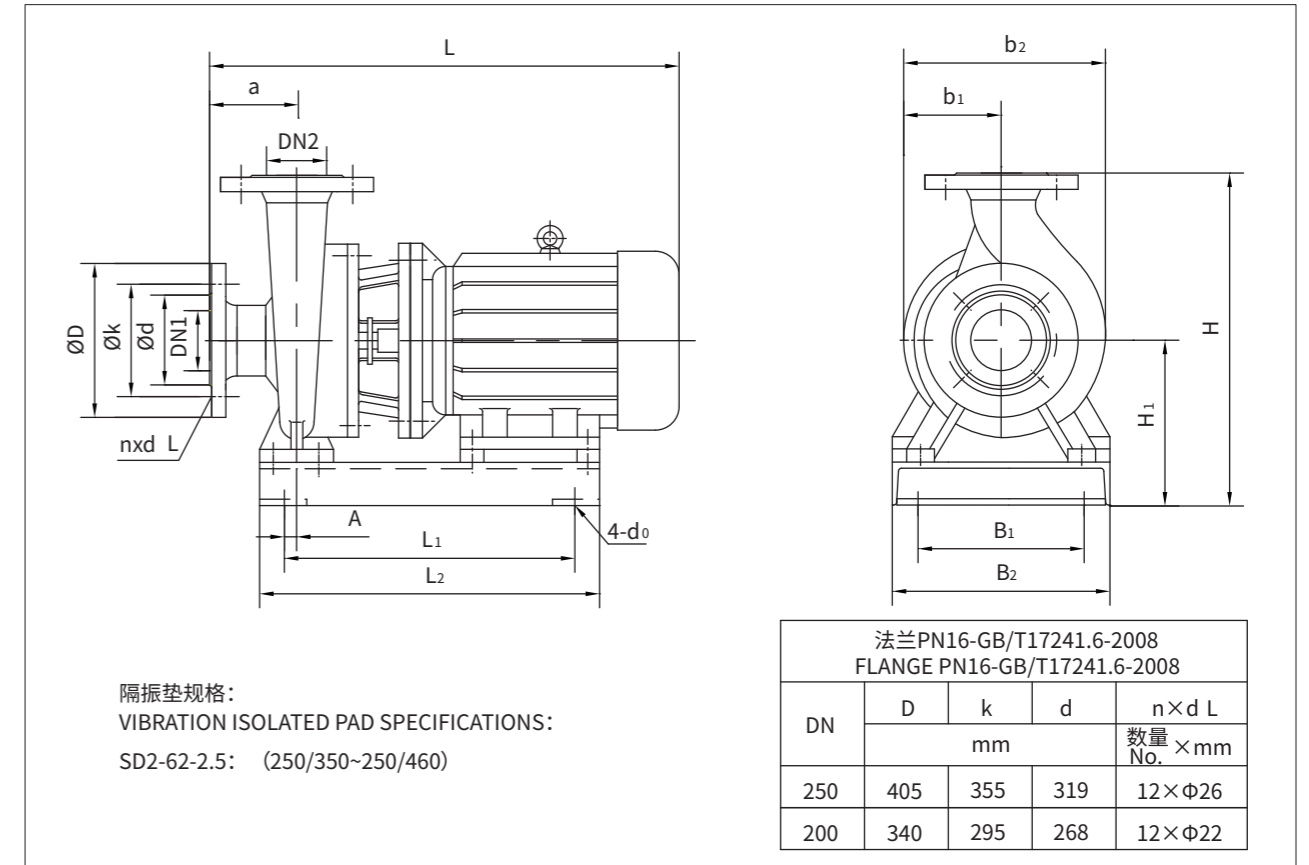

DIMENSION TABLE
KQL尺寸表

型号 TYPE	DN	l ₀	m	a	c			b ₁	b ₂	x
		mm								
250KQL500-41-75/4N	250	1200	600	360	40	1082	307	695	205	
250KQL500-44-90/4N	250	1200	600	360	40	1133	307	695	205	
250KQL500-50-90/4N	250	1200	600	360	40	1133	307	695	205	
250KQL600-50-110/4N	250	1200	600	360	40	1324	330	857	205	
250KQL480-60-132/4	250	1360	650	380	40	1396	450	880	205	
250KQL515-70-160/4	250	1360	650	380	40	1380	450	880	205	
250KQL550-80-200/4	250	1360	650	380	40	1380	450	880	205	

DIMENSION TABLE
KQW尺寸表

型号 TYPE	外形尺寸 Figure dimensions				安装尺寸 Installing dimensions							DN1	DN2	
	L	H	b ₂	b ₁	4-φ ₀	a	L ₁	B ₁	L ₂	B ₂	H ₁			A
250KQW500-41-75/4N	1245	1044	693	320	4-φ20	200	750	500	960	640	494	30	250	200
250KQW500-44-90/4N	1295	1044	693	320	4-φ20	200	800	500	990	640	494	30	250	200
250KQW500-50-90/4N	1295	1044	693	320	4-φ20	200	800	500	990	640	494	30	250	200
250KQW600-50-110/4N	1500	1044	710	330	4-φ25	200	850	550	1070	640	494	30	250	200
250KQW480-60-132/4	1600	1144	731	341	4-φ25	220	900	550	1170	640	494	30	250	250
250KQW515-70-160/4	1600	1144	731	341	4-φ25	220	900	550	1170	640	494	30	250	250
250KQW550-80-200/4	1600	1144	731	341	4-φ25	220	900	550	1170	640	494	30	250	250

CHARACTERISTIC CURVE
性能曲线

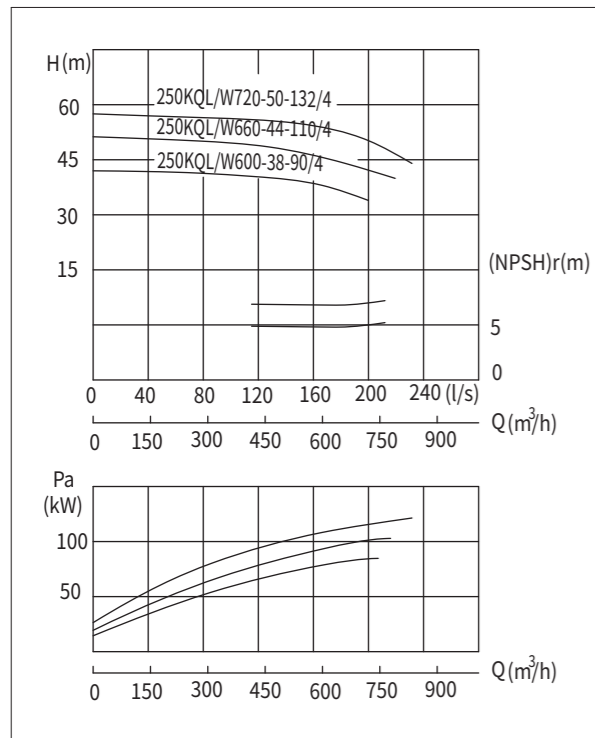
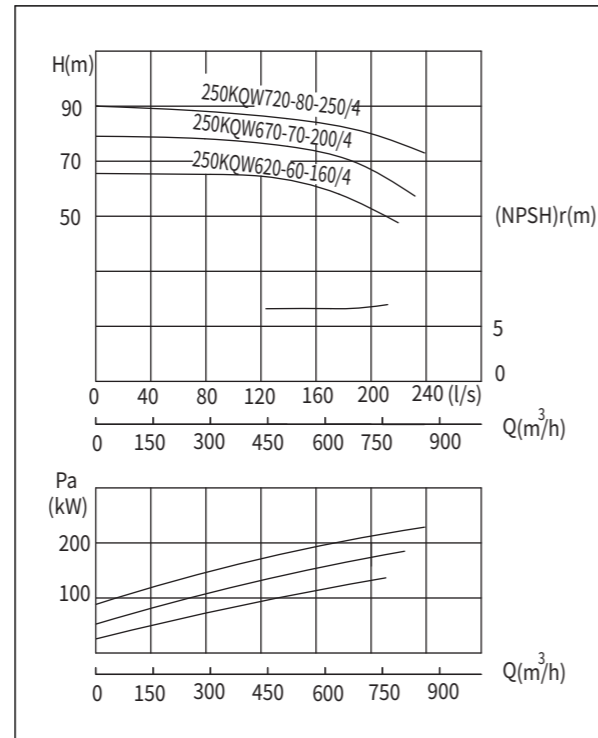
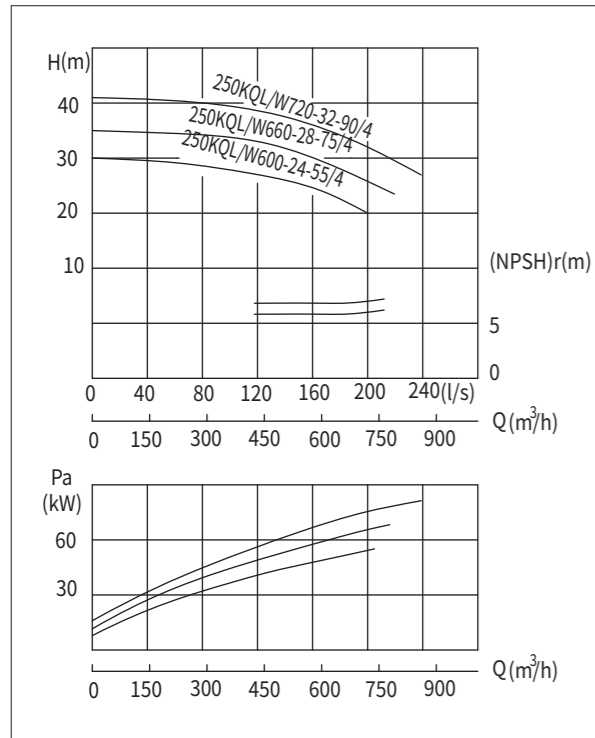

PERFORMANCE DATA
参数表

型号 TYPE	流量 Capacity		扬程 Head (m)	转速 Speed (r/min)	效率 Efficiency (%)	电机 功率 Power (kW)	必需 汽蚀 余量 (NPSH)r (m)	重量 Weight (kg)
	(m³/h)	(l/s)						
250KQL600-24-55/4 250KQW600-24-55/4	420	116.7	26.5	1480	81	55	8 6	825
	600	166.7	24					
	720	200.0	20					
250KQL660-28-75/4 250KQW660-28-75/4	460	127.8	32.6	1480	83	75	8 6	880
	660	183.3	28					
	790	219.4	23.5					
250KQL720-32-90/4 250KQW720-32-90/4	500	138.9	38.4	1480	85.8	90	8 6	950
	720	200.0	32					
	860	238.9	27					
250KQL600-38-90/4 250KQW600-38-90/4	420	116.7	40.5	1480	81	90	7 5	1050
	600	166.7	38					
	720	200.0	34					
250KQL660-44-110/4 250KQW660-44-110/4	460	127.8	48.5	1480	83	110	7 5	1306
	660	183.3	44					
	790	219.4	41					
250KQL720-50-132/4 250KQW720-50-132/4	500	138.9	55	1480	85.8	132	7 5	1400
	720	200.0	50					
	860	238.9	44					
250KQW620-60-160/4	430	119.4	64.5	1480	79	160	6.5	1815
	620	172.2	60					
	740	205.6	57					
250KQW670-70-200/4	465	129.2	75	1480	81	200	6.5	1920
	670	186.1	70					
	800	222.2	62					
250KQW720-80-250/4	500	138.9	83.5	1480	83.8	250	6.5	2535
	720	200.0	80					
	860	238.9	73					

DIMENSION FIGURE
尺寸图

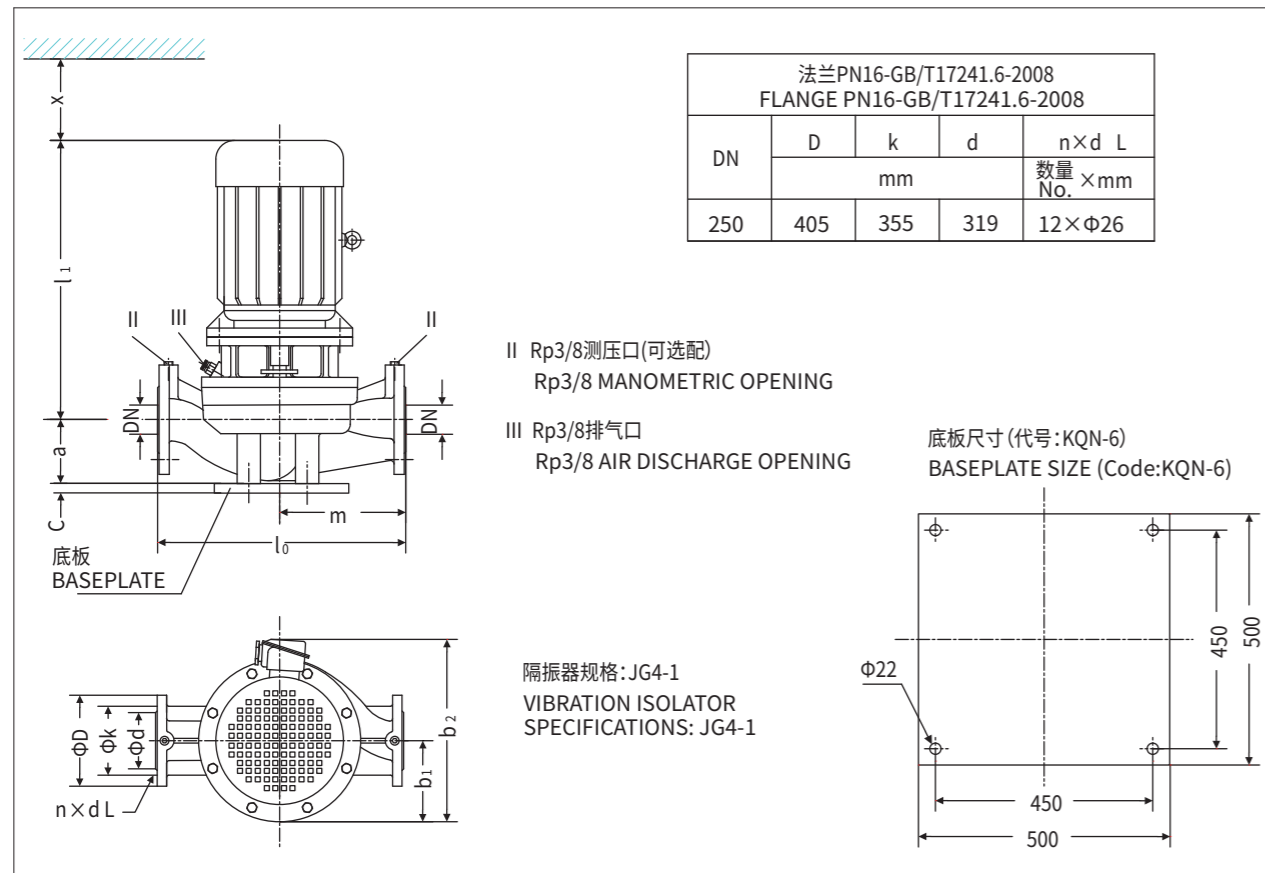

DIMENSION TABLE
KQL尺寸表

型号 TYPE	DN	l ₀	m	a	c	l ₁	b ₁	b ₂	x
250KQL600-24-55/4	250	1100	550	335	40	960	280	640	205
250KQL660-28-75/4	250	1100	550	335	40	1032	280	668	205
250KQL720-32-90/4	250	1100	550	335	40	1083	280	668	205
250KQL600-38-90/4	250	1200	600	360	40	1133	307	695	205
250KQL660-44-110/4	250	1200	600	360	40	1324	330	857	205
250KQL720-50-132/4	250	1200	600	360	40	1434	330	857	205

DIMENSION FIGURE
尺寸图

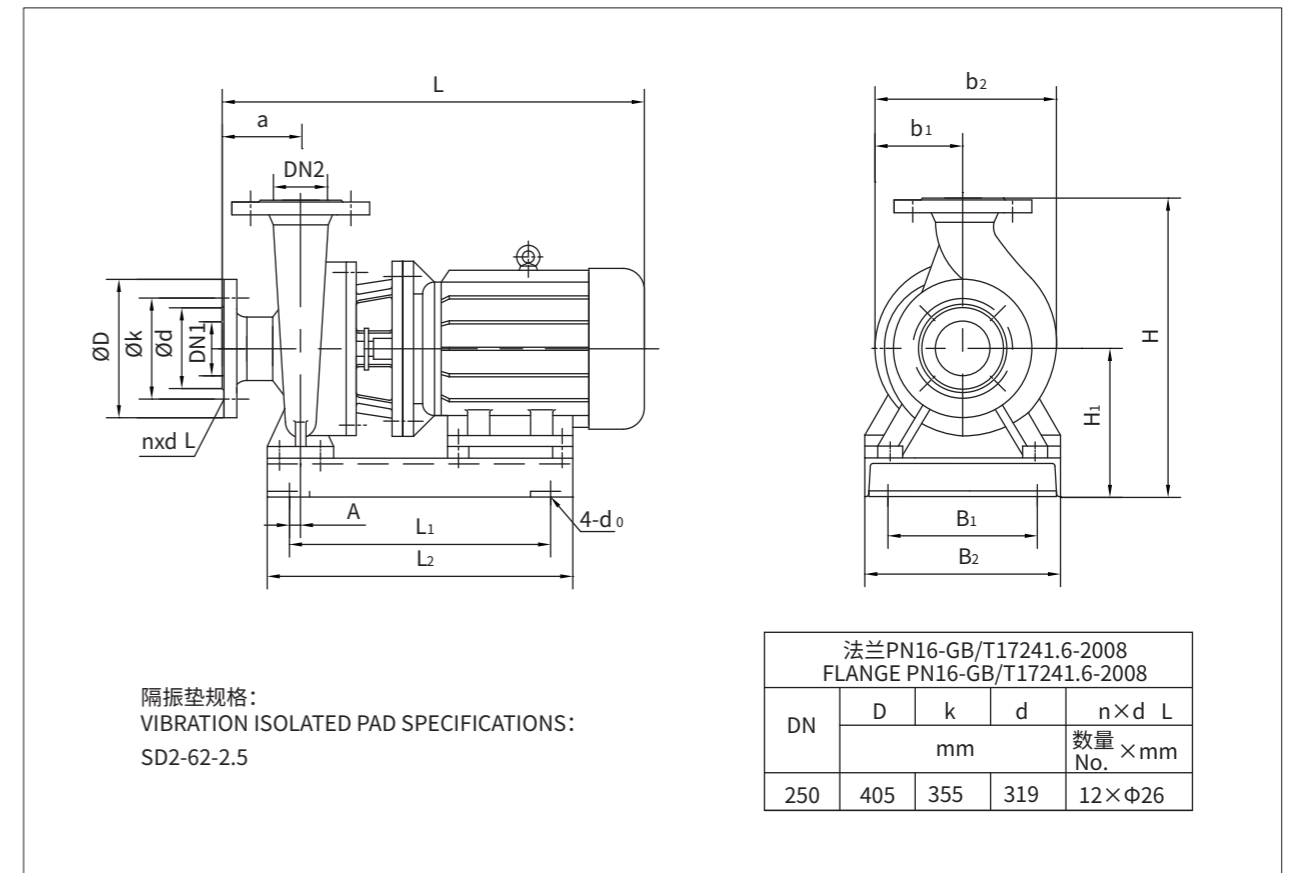

DIMENSION TABLE
KQW尺寸表

型号 TYPE	外形尺寸 Figure dimensions				安装尺寸 Installing dimensions							DN1	DN2	
	L	H	b ₂	b ₁	4-φ ₀	a	L ₁	B ₁	L ₂	B ₂	H ₁			A
250KQW600-24-55/4	1169	989	660	320	4-φ20	200	630	500	880	640	439	30	250	250
250KQW660-28-75/4	1245	989	660	320	4-φ20	200	710	500	935	640	439	30	250	250
250KQW720-32-90/4	1285	989	660	320	4-φ20	200	800	500	990	640	439	30	250	250
250KQW600-38-90/4	1295	1044	693	320	4-φ20	200	800	500	990	640	494	30	250	200
250KQW660-44-110/4	1500	1044	710	330	4-φ25	200	850	550	1070	640	494	30	250	200
250KQW720-50-132/4	1610	1044	710	330	4-φ25	200	950	550	1180	640	494	30	250	200
250KQW620-60-160/4	1670	1317	815	386	4-φ25	250	950	625	1220	720	567	20	250	250
250KQW670-70-200/4	1670	1317	815	386	4-φ25	250	950	625	1220	720	567	20	250	250
250KQW720-80-250/4	1850	1301	830	400	4-φ25	250	1020	650	1340	750	551	20	250	250

CHARACTERISTIC CURVE
性能曲线

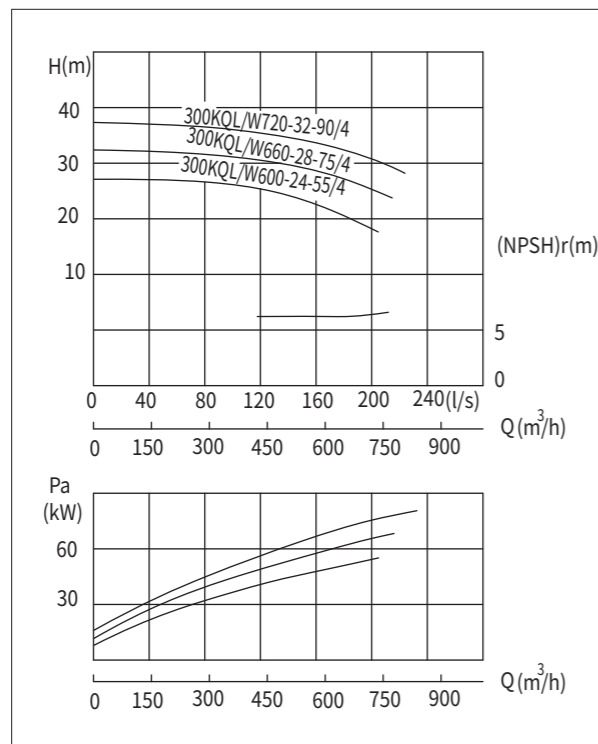
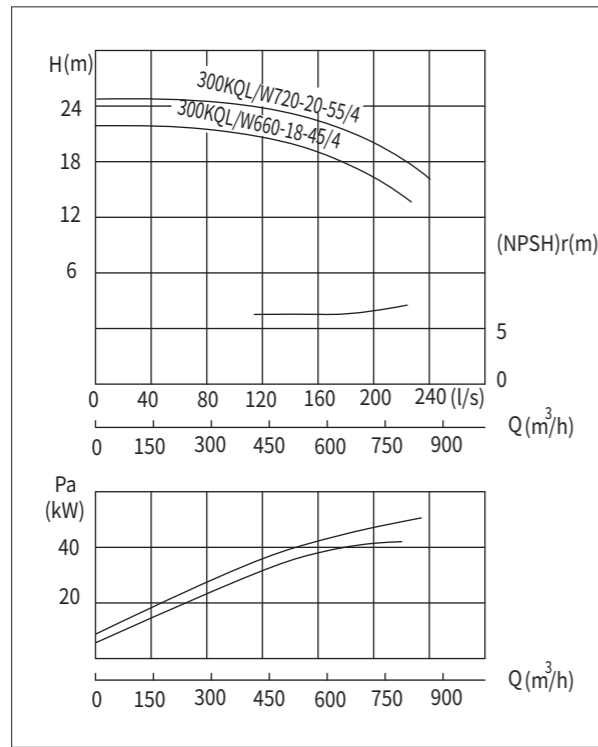

PERFORMANCE DATA
参数表

型号 TYPE	流量 Capacity		扬程 Head (m)	转速 Speed (r/min)	效率 Efficiency (%)	电机 功率 Power (kW)	必需 汽蚀 余量 (NPSH)r (m)	重量 Weight (kg)
	(m³/h)	(l/s)						
300KQL/W660-18-45/4	460	127.8	20	1480	82	45	6.0	710
	660	183.3	17.5					
	790	219.4	14					
300KQL/W720-20-55/4	500	138.9	23	1480	84.2	55	6.0	820
	720	200.0	20					
	860	239.0	16					
300KQL/W600-24-55/4	420	116.7	26.5	1480	81	55	6.0	805
	600	166.7	24					
	720	200.0	20.6					
300KQL/W660-28-75/4	460	127.8	30.5	1480	83	75	6.0	938
	660	183.3	28					
	790	219.4	24					
300KQL/W720-32-90/4	500	138.9	35	1480	85.8	90	6.0	1043
	720	200.0	32					
	860	239.0	28					

DIMENSION FIGURE
尺寸图

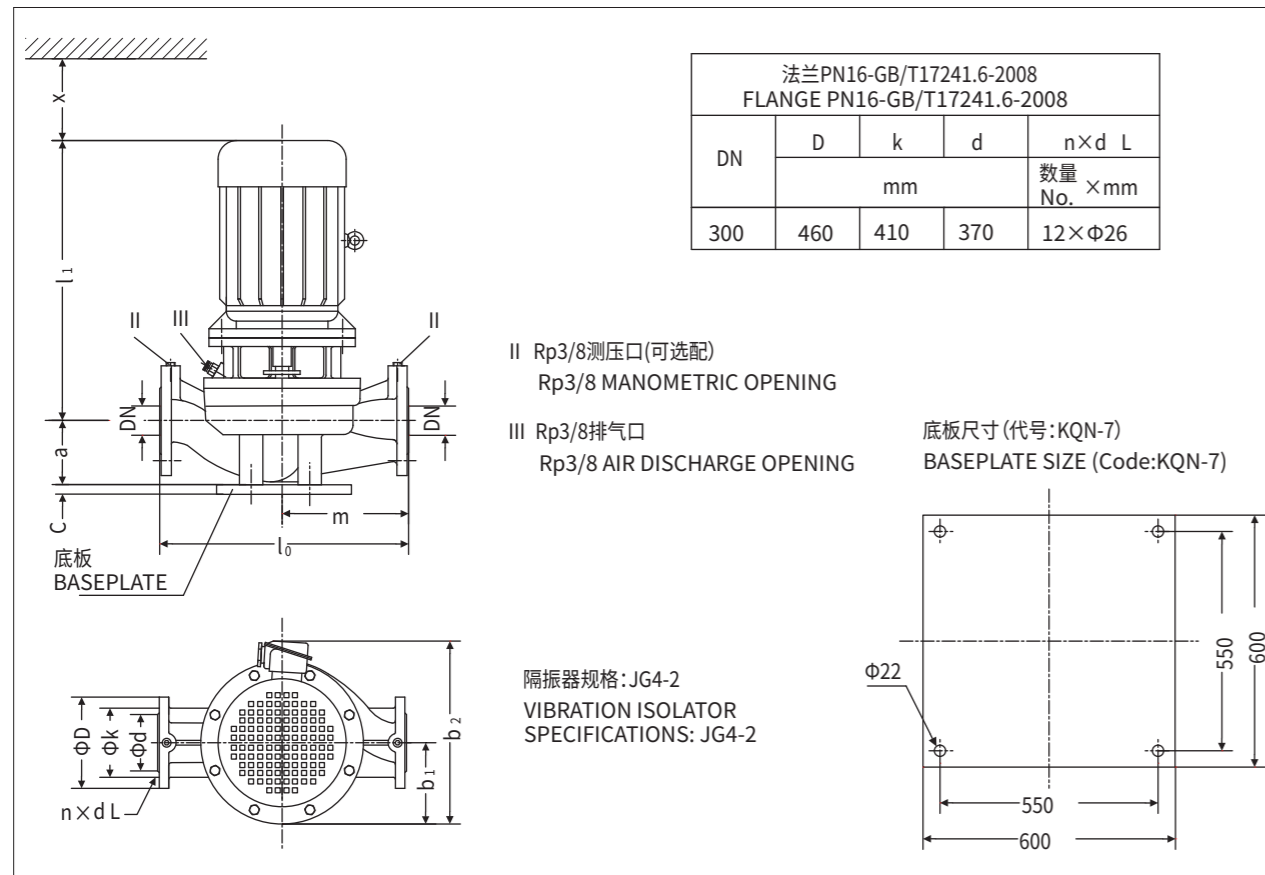

DIMENSION TABLE
KQL尺寸表

型号 TYPE	DN	l ₀	m	a	c	l ₁	b ₁	b ₂	x
300KQL660-18-45/4	300	1250	625	390	45	937	305	710	230
300KQL720-20-55/4	300	1250	625	390	45	1001	325	725	230
300KQL600-24-55/4	300	1250	625	390	45	1001	325	725	230
300KQL660-28-75/4	300	1250	625	390	45	1077	360	760	230
300KQL720-32-90/4	300	1250	625	390	45	1115	360	760	230

DIMENSION FIGURE
尺寸图

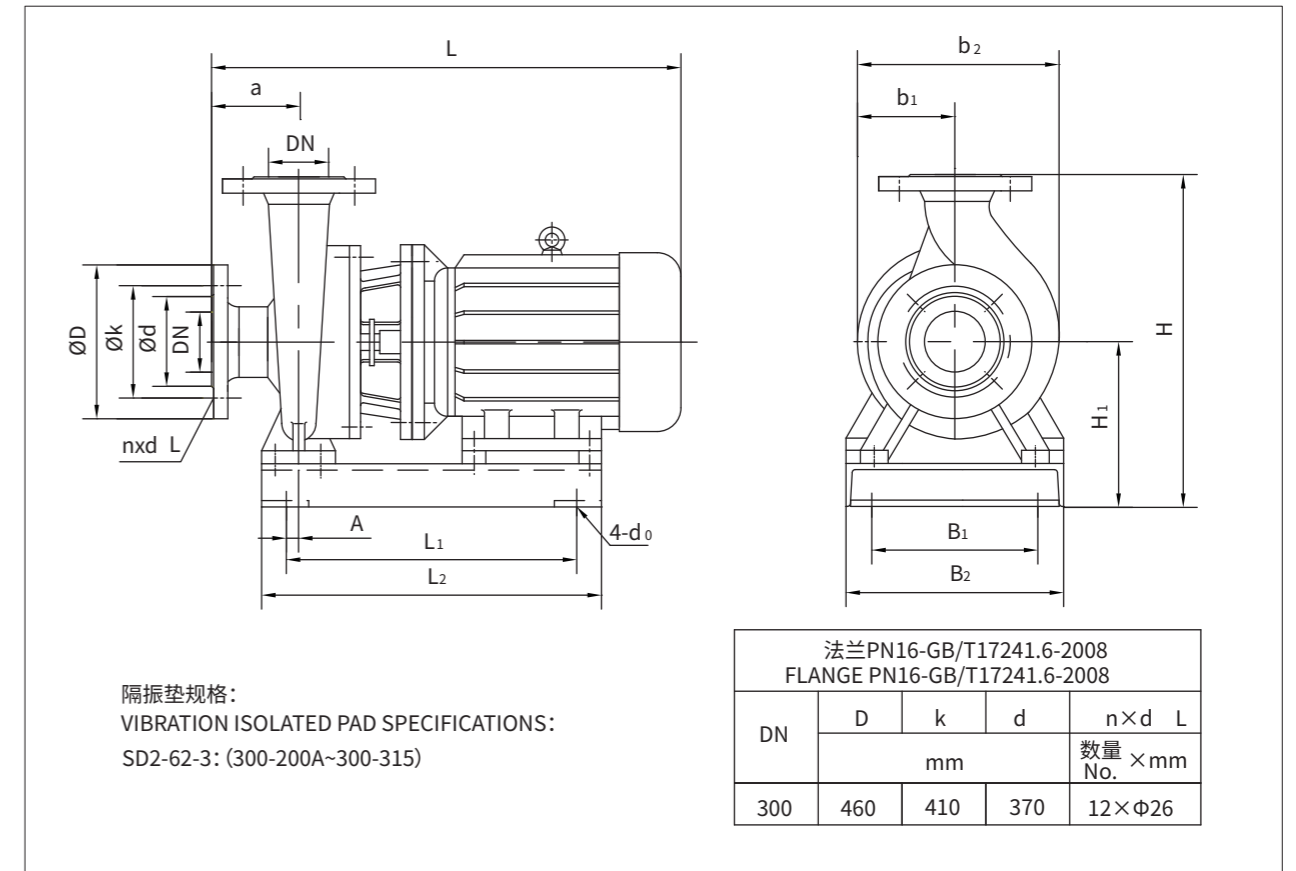

DIMENSION TABLE
KQW尺寸表

型号 TYPE	外形尺寸 Figure dimensions				安装尺寸 Installing dimensions							DN	
	L	H	b ₂	b ₁	4-d ₀	a	L ₁	B ₁	L ₂	B ₂	H ₁		A
300KQW660-18-45/4	1178	1081	695	300	4-Φ25	253	710	430	930	560	484	110	300
300KQW720-20-55/4	1238	1081	695	300	4-Φ25	253	780	430	975	640	484	110	300
300KQW600-24-55/4	1238	1081	695	300	4-Φ25	253	780	430	1000	640	481	110	300
300KQW660-28-75/4	1318	1081	695	300	4-Φ25	253	850	430	1015	640	481	110	300
300KQW720-32-90/4	1358	1081	720	300	4-Φ25	253	890	430	1065	640	481	110	300

CHARACTERISTIC CURVE
性能曲线

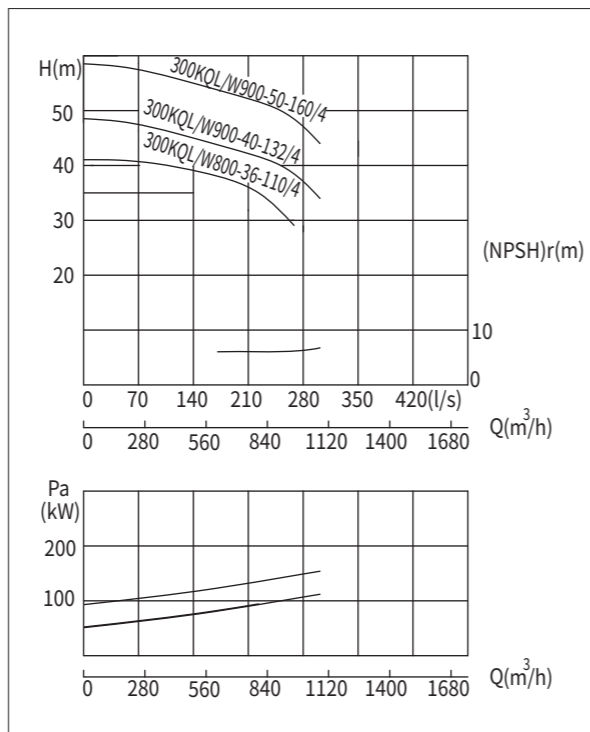
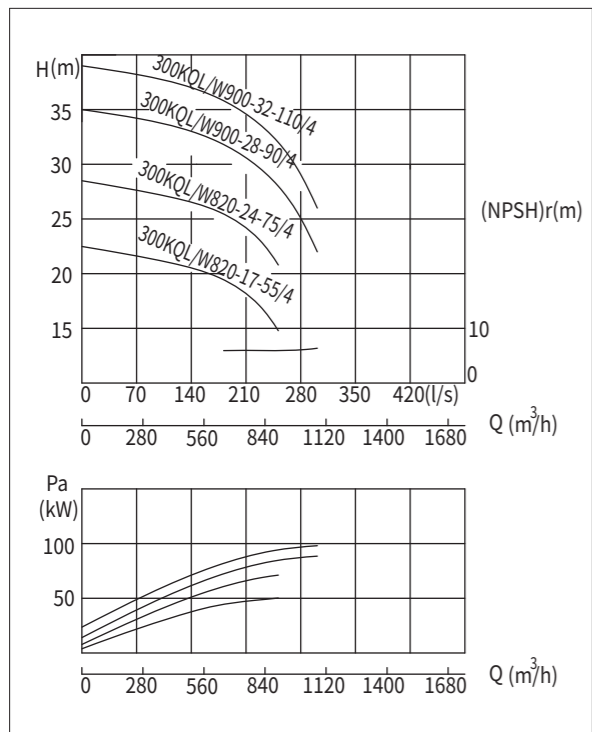
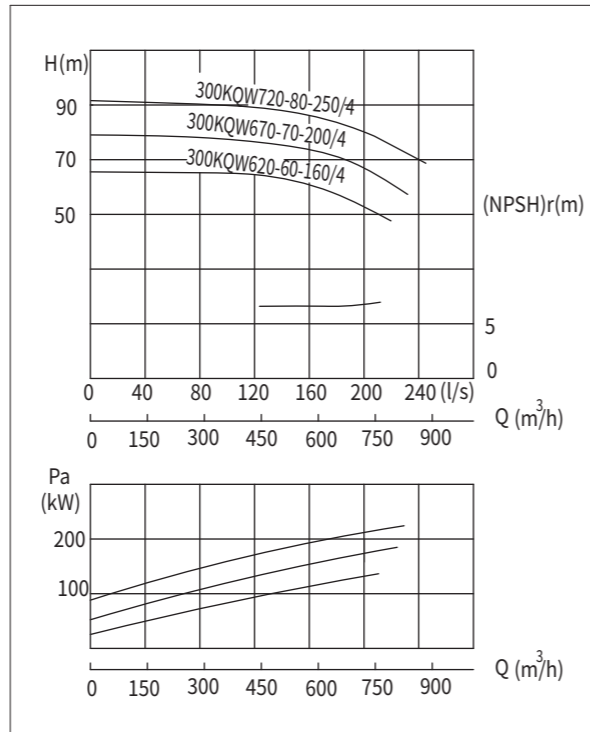
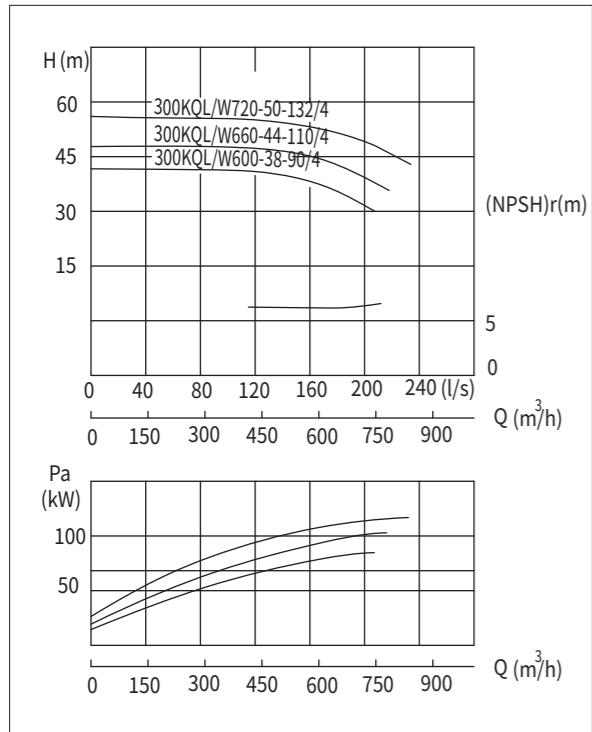

PERFORMANCE DATA
参数表

型号 TYPE	流量 Capacity		扬程 Head (m)	转速 Speed (r/min)	效率 Efficiency (%)	电机 功率 Power (kW)	必需 汽蚀 余量 (NPSH)r (m)	重量 Weight (kg)
	(m³/h)	(l/s)						
300KQL/W600-38-90/4	420	116.7	42	1480	81	90	6.0	1160
	600	166.7	38					
	720	200	34					
300KQL/W660-44-110/4	460	127.8	49	1480	83	110	6.0	1450
	660	183.3	44					
	790	219.4	37					
300KQL/W720-50-132/4	500	138.9	55	1480	85.8	132	6.0	1650
	720	200	50					
	860	239	42					
300KQW620-60-160/4	430	119.4	64.5	1480	79	160	6.5	1720
	620	172.2	60					
	740	205.6	54					
300KQW670-70-200/4	465	129.2	75	1480	81	200	6.5	1757
	670	186.1	70					
	800	222.2	60.4					
300KQW720-80-250/4	500	138.9	86	1480	83.8	250	6.5	2342
	720	200.0	80					
	860	239.0	69					
300KQL/W820-17-55/4	574	159.0	19.9	1480	79	55	6.0	886
	820	227.8	17					
	900	250.0	15					
300KQL/W820-24-75/4	574	159	26.5	1480	80	75	6.0	1015
	820	228	24					
	900	250	22					
300KQL/W900-28-90/4	630	175	33	1480	83	90	6.0	1180
	900	250	28					
	1080	300	22					
300KQL/W900-32-110/4	630	175	36	1480	85	110	6.0	1500
	900	250	32					
	1080	300	27					
300KQL/W800-36-110/4	560	155.6	42	1480	83	110	6	1480
	800	222.2	36					
	960	266.7	29					
300KQL/W900-40-132/4	630	175	46	1480	84.5	132	6	1585
	900	250	40					
	1080	300	34					
300KQL/W900-50-160/4	630	175	56.5	1480	86	160	6	1590
	900	250	50					
	1080	300	44					

DIMENSION FIGURE
尺寸图

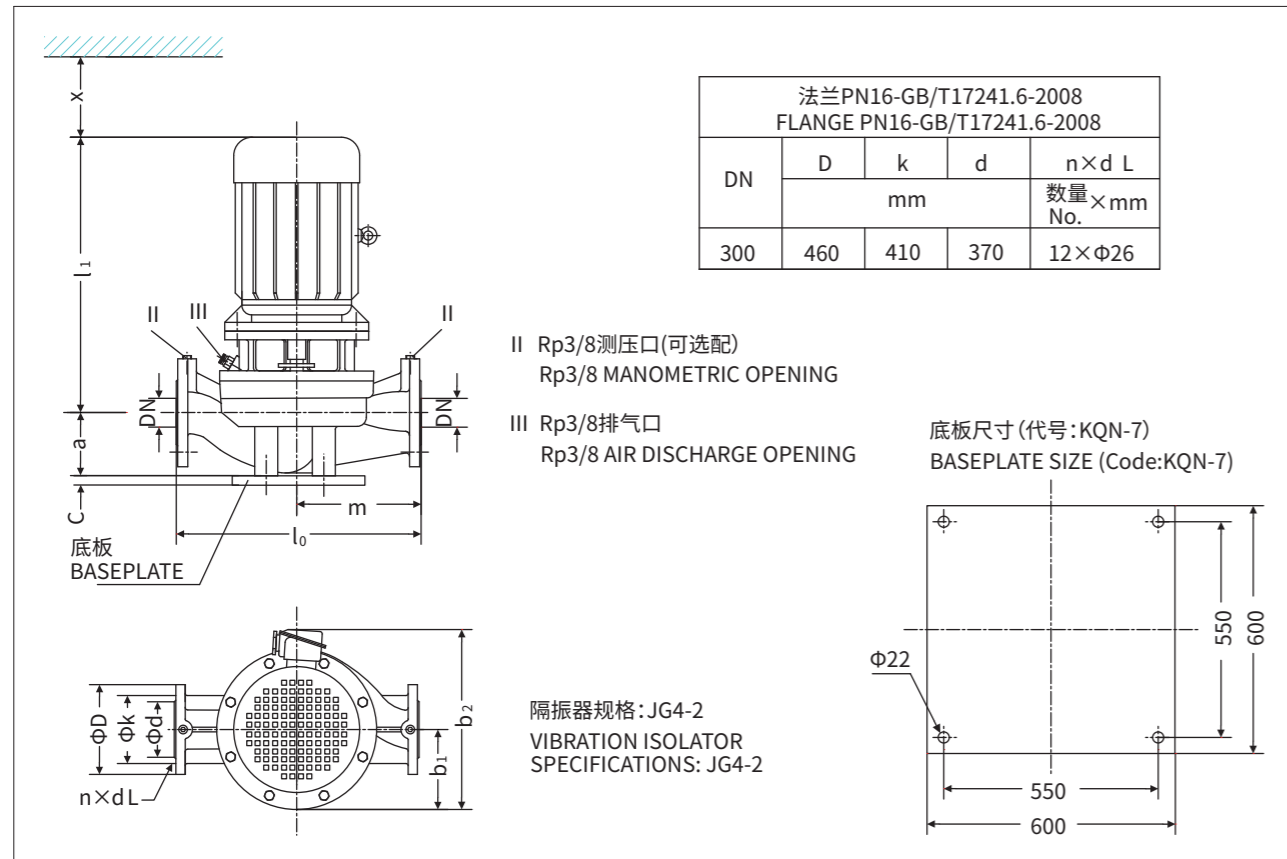

DIMENSION FIGURE
尺寸图

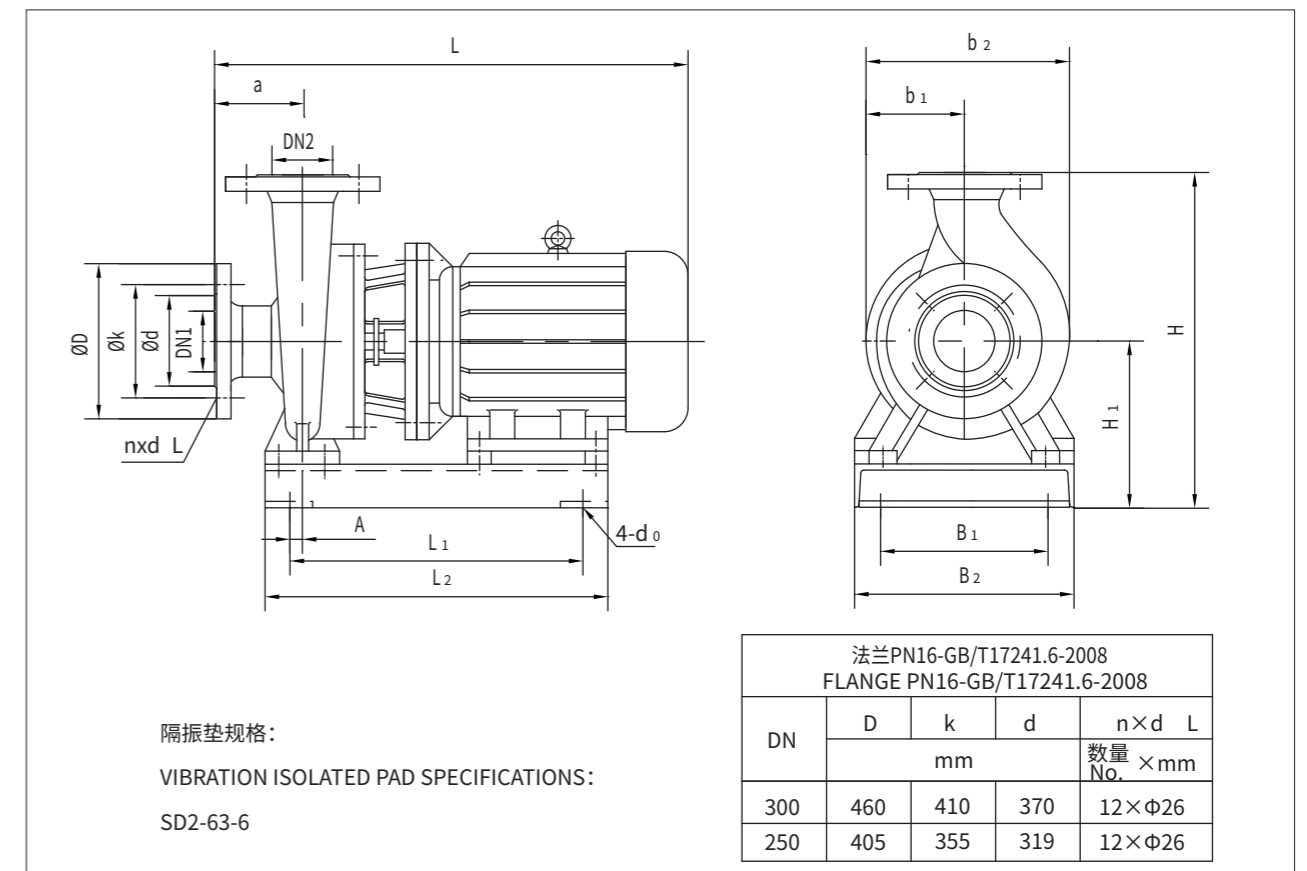

DIMENSION TABLE
KQL尺寸表

型号 TYPE	DN	l ₀	m	a	c	l ₁	b ₁	b ₂	x
		mm							
300KQL600-38-90/4	300	1300	650	400	45	1095	385	835	230
300KQL660-44-110/4	300	1300	650	400	45	1350	450	980	230
300KQL720-50-132/4	300	1300	650	400	45	1380	450	980	230
300KQL820-17-55/4	300	1250	625	390	45	975	326	736	230
300KQL820-24-75/4	300	1250	625	390	45	1077	360	760	230
300KQL900-28-90/4	300	1250	625	390	45	1095	326	736	230
300KQL900-32-110/4	300	1250	625	390	45	1350	326	856	230
300KQL800-36-110/4	300	1345	670	410	45	1334	336	865	230
300KQL900-40-132/4	300	1345	670	410	45	1444	336	865	230
300KQL900-50-160/4	300	1345	670	410	45	1444	336	865	230

DIMENSION TABLE
KQW尺寸表

型号 TYPE	外形尺寸 Figure dimensions				安装尺寸 Installing dimensions								DN1	DN2
	L	H	b ₂	b ₁	4-φ ₀	a	L ₁	B ₁	L ₂	B ₂	H ₁	A		
300KQW600-38-90/4	1355	1134	674	320	4-φ25	250	800	550	1025	640	484	30	300	300
300KQW660-44-110/4	1600	1134	674	320	4-φ25	250	850	550	1090	640	484	30	300	300
300KQW720-50-132/4	1630	1134	674	320	4-φ25	250	950	550	1195	640	484	30	300	300
300KQW620-60-160/4	1630	1400	835	390	4-φ25	250	900	625	1185	720	600	30	300	300
300KQW670-70-200/4	1620	1400	835	390	4-φ25	250	900	625	1185	720	600	30	300	300
300KQW720-80-250/4	1840	1382	846	400	4-φ25	250	1020	650	1315	750	582	30	300	300
300KQW820-17-55/4	1220	1119	695	300	4-φ25	250	850	550	1015	640	519	50	300	300
300KQW820-24-75/4	1308	1081	695	300	4-φ25	253	850	430	1015	640	481	110	300	300
300KQW900-28-90/4	1345	1119	720	323	4-φ25	250	900	550	1055	640	519	50	300	300
300KQW900-32-110/4	1550	1119	720	323	4-φ25	250	920	550	1090	640	519	50	300	300
300KQW800-36-110/4	1620	1179	980	450	4-φ25	290	900	550	1150	640	509	30	300	250
300KQW900-40-132/4	1650	1179	980	450	4-φ25	290	950	550	1195	640	509	30	300	250
300KQW900-50-160/4	1650	1179	980	450	4-φ25	290	950	550	1195	640	509	30	300	250

CHARACTERISTIC CURVE
性能曲线

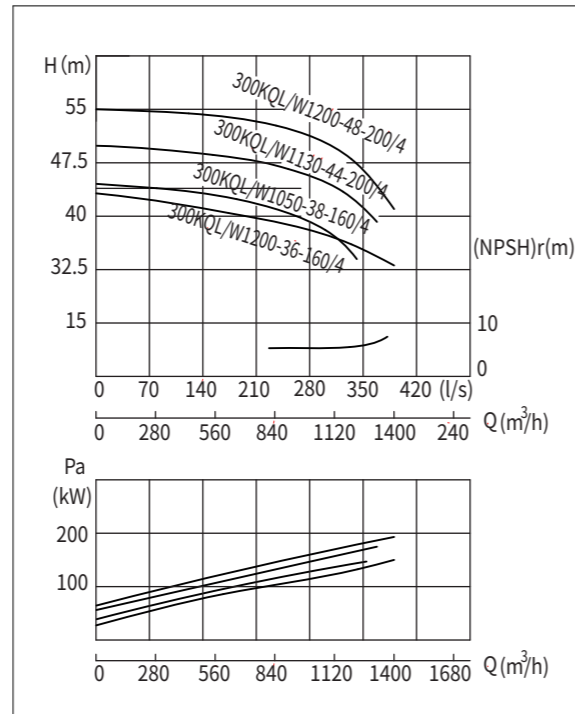
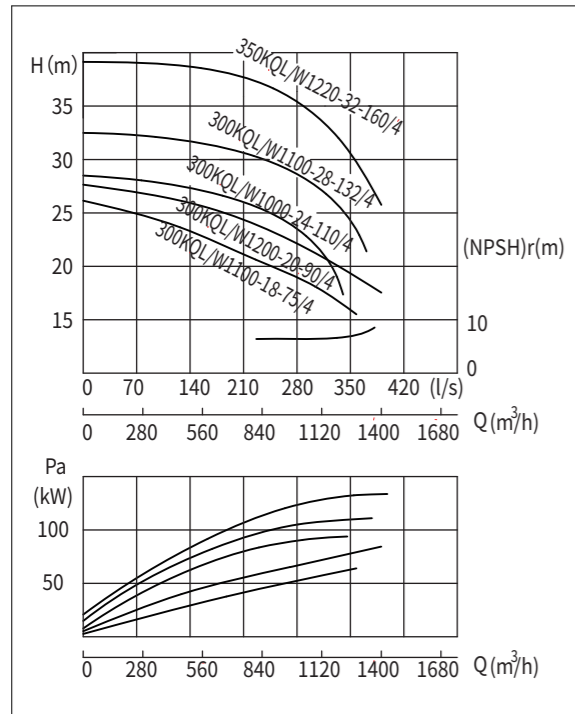

PERFORMANCE DATA
参数表

型号 TYPE	流量 Capacity		扬程 Head (m)	转速 Speed (r/min)	效率 Efficiency (%)	电机功率 Power (kW)	必需汽蚀 余量 (NPSH)r (m)	重量 Weight (kg)
	(m³/h)	(l/s)						
300KQL/W1100-18-75/4	820	227.7	21	1480	81	75	7	1110
	1100	305.5	18					
	1320	366.7	16					
300KQL/W1200-20-90/4	900	233.3	23.5	1480	83	90	7	1180
	1200	333.3	20					
	1400	388.9	17					
300KQL/W1000-24-110/4	750	208.3	27	1480	81	110	7	1480
	1000	277.8	24					
	1200	333.3	21					
300KQL/W1100-28-132/4	820	227.8	31	1480	83	132	7	1590
	1100	305.6	28					
	1300	361.1	23					
300KQL/W1200-32-160/4	900	250	38	1480	86.3	160	7	1686
	1200	333.3	32					
	1400	388.9	26					
300KQL/W1200-36-160/4	900	250	42	1480	84.5	160	7	1690
	1200	333.3	36					
	1400	388.9	30					
300KQW1050-38-160/4	790	219.4	41	1480	83	160	7	1765
	1050	291.7	38					
	1225	340.3	34					
300KQW1130-44-200/4	850	236.1	47.5	1480	84	200	7	1875
	1130	313.9	44					
	1320	366.7	39.4					
300KQW1200-48-200/4	900	250	52.5	1480	85	200	7	1875
	1200	333.3	48					
	1400	388.9	41					
300KQL/W720-11-37/6	500	138.9	14	980	76	37	6.5	1188
	720	200	11					
	860	238.9	9					
300KQL/W820-13-45/6	574	159.4	16	980	78	45	6.5	1245
	820	227.8	13					
	930	258.3	11.5					

DIMENSION FIGURE
尺寸图

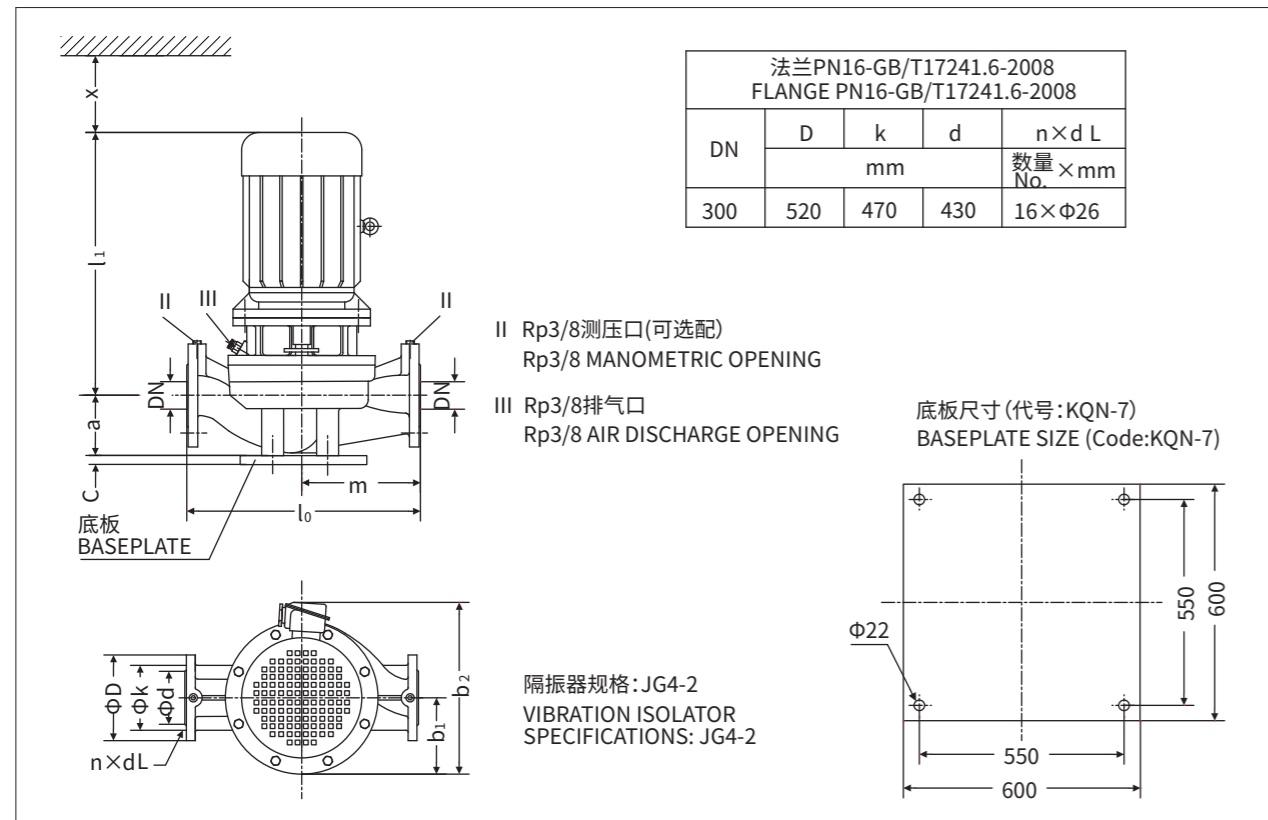

DIMENSION FIGURE
尺寸图

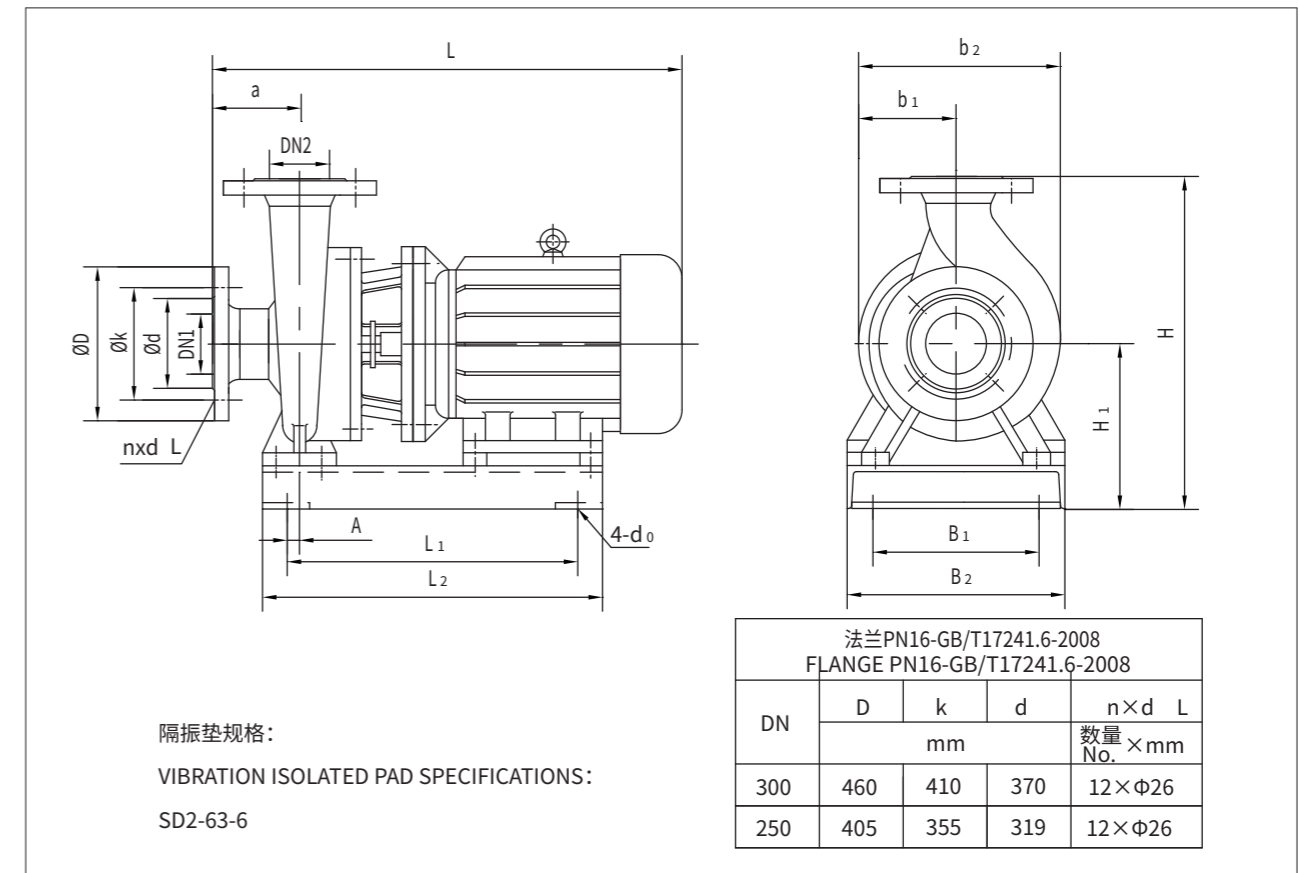

DIMENSION TABLE
KQL尺寸表

型号 TYPE	DN	l ₀	m	a	c	l ₁	b ₁	b ₂	x
300KQL1100-18-75/4	300	1380	650	430	45	1102	345	780	250
300KQL1200-20-90/4	300	1380	650	430	45	1153	345	780	250
300KQL1000-24-110/4	300	1380	650	430	45	1334	345	870	250
300KQL1100-28-132/4	300	1380	650	430	45	1444	345	870	250
300KQL1200-32-160/4	300	1380	650	430	45	1444	345	870	250
300KQL1200-36-160/4	300	1380	650	430	45	1444	345	870	250
300KQL720-11-37/6	300	1380	650	430	45	1020	345	780	250
300KQL820-13-45/6	300	1380	650	430	45	1102	345	780	250

DIMENSION TABLE
KQW尺寸表

型号 TYPE	外形尺寸 Figure dimensions				安装尺寸 Installing dimensions							DN1	DN2	
	L	H	b ₂	b ₁	4-d ₀	a	L ₁	B ₁	L ₂	B ₂	H ₁			A
300KQW1100-18-75/4	1275	1069	770	342	4-Φ25	250	850	430	985	640	519	110	300	250
300KQW1200-20-90/4	1325	1069	770	342	4-Φ25	250	890	430	1035	640	519	110	300	250
300KQW1000-24-110/4	1550	1069	770	342	4-Φ25	250	920	550	1090	640	519	50	300	250
300KQW1100-28-132/4	1660	1069	770	342	4-Φ25	250	1020	550	1200	640	519	50	300	250
300KQW1200-32-160/4	1660	1069	770	342	4-Φ25	250	1020	550	1200	640	519	50	300	250
300KQW1200-36-160/4	1660	1069	770	342	4-Φ25	250	1020	550	1200	640	519	50	300	250
300KQW1050-38-160/4	1660	1169	745	332	4-Φ25	240	1015	625	1215	720	569	50	300	250
300KQW1130-44-200/4	1660	1169	745	332	4-Φ25	240	1015	625	1215	720	569	50	300	250
300KQW1200-48-200/4	1660	1169	745	332	4-Φ25	240	1015	625	1215	720	569	50	300	250
300KQW720-11-37/6	1305	1070	770	342	4-Φ25	250	750	550	940	640	520	50	300	250
300KQW820-13-45/6	1305	1070	770	342	4-Φ25	250	800	550	985	640	520	50	300	250

CHARACTERISTIC CURVE
性能曲线

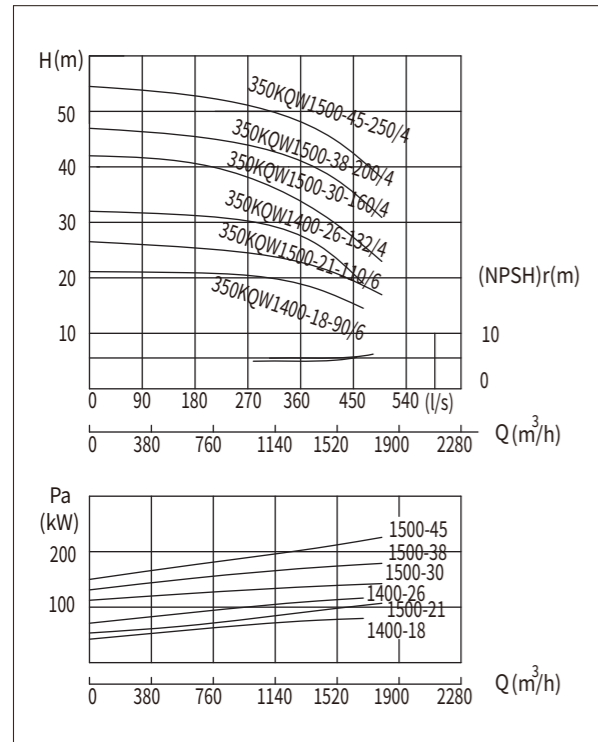

PERFORMANCE DATA
参数表

型号 TYPE	流量 Capacity		扬程 Head (m)	转速 Speed (r/min)	效率 Efficiency (%)	电机 功率 Power (kW)	必需 汽蚀 余量 (NPSH)r (m)	重量 Weight (kg)
	(m³/h)	(l/s)						
350KQW1400-18-90/6	1050	291.7	20	990	79	90	5	1664
	1190	330.6	19		81.2		5	
	1400	388.9	18		86.5		5	
	1540	427.8	16		85.5		5.7	
	1680	466.7	14.5		83.1		6	
350KQW1500-21-110/6	1125	312.5	23.5	990	79.5	110	5	1740
	1275	354.2	22.8		84.5		5	
	1500	416.7	21		88		5	
	1650	458.3	19		87.6		5.7	
	1800	500.0	17		85.6		6	
350KQW1400-26-132/4	1050	291.7	30.8	1480	79.5	132	6.5	1625
	1190	330.6	29.5		82		6.5	
	1400	388.9	26		85		6.5	
	1540	427.8	23.3		82.3		6.7	
	1680	466.7	19		78		7	
350KQW1500-30-160/4	1125	312.5	34.5	1480	79	160	6.5	1718
	1275	354.2	32.5		84		6.5	
	1500	416.7	30		86.5		6.5	
	1650	458.3	26.6		85.2		6.7	
	1800	500.0	23.1		80.5		7	
350KQW1500-38-200/4	1125	312.5	42.5	1480	80	200	6.5	1835
	1275	354.2	40.5		85.5		6.5	
	1500	416.7	38		88		6.5	
	1650	458.3	34.8		86.7		6.7	
	1800	500.0	30.2		82		7	
350KQW1500-45-250/4	1125	312.5	50.5	1480	80	250	6.5	2427
	1275	354.2	47.5		83.5		6.5	
	1500	416.7	45		88		6.5	
	1650	458.3	42		86.5		6.7	
	1800	500.0	38		81.5		7	

DIMENSION FIGURE
尺寸图

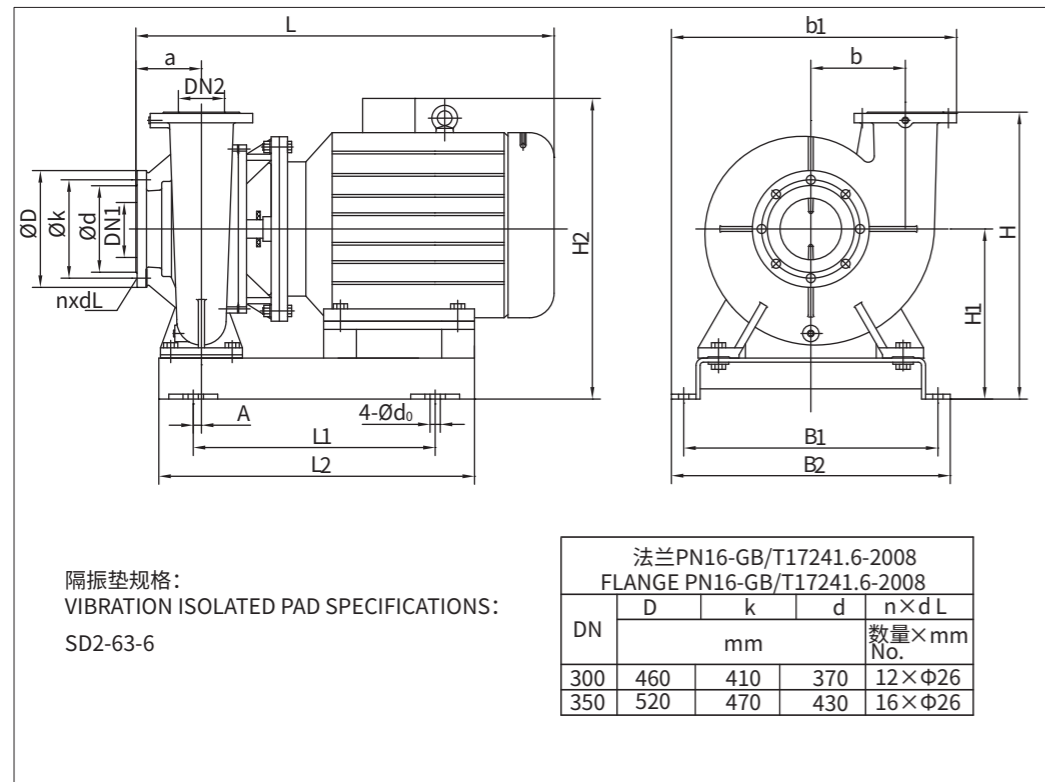

ACCESSORIES AND INSTALLING BASIC DIMENSIONS CHART
附件及安装基础尺寸图表

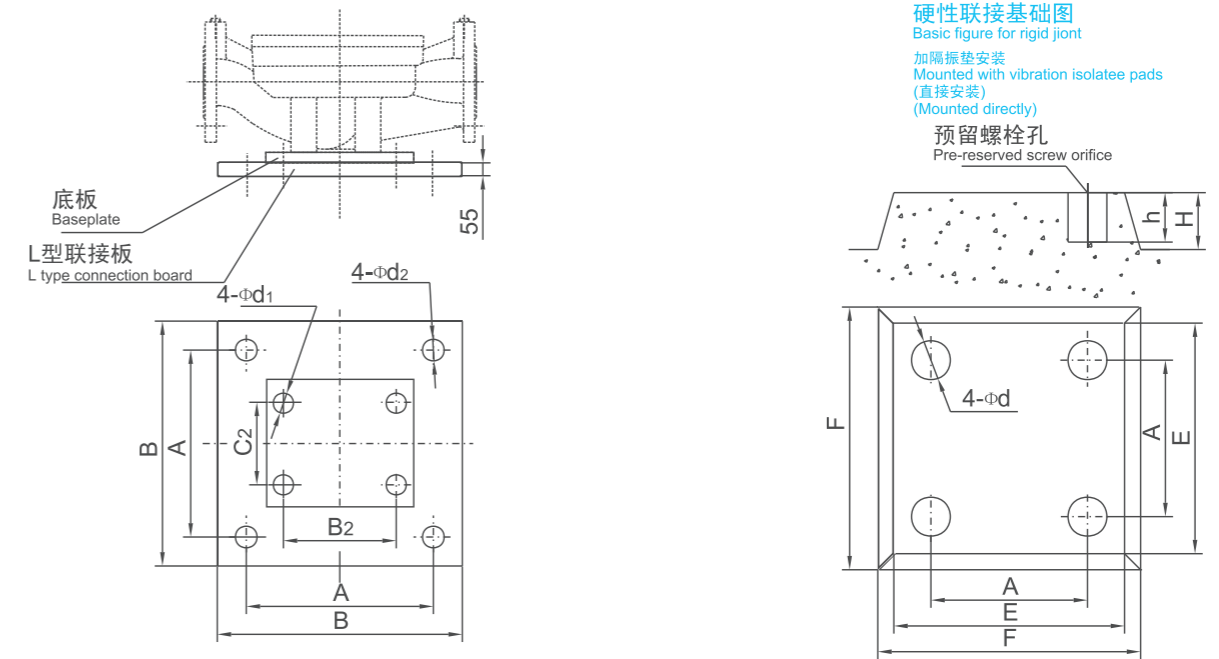

DIMENSION TABLE
KQW尺寸表

型号 TYPE	外形尺寸 Figure dimensions			安装尺寸 Installing dimensions									DN1	DN2	隔振垫	
	L	H ₂	b ₁	4-φ ₀	a	b	L ₁	B ₁	L ₂	B ₂	H	H ₁				A
350KQW1400-18-90/6	1675	1210	1080	4-φ25	255	380	850	840	1210	910	1180	680	0	350	300	SD2-63-6
350KQW1500-21-110/6	1675	1210	1080	4-φ25	255	380	850	840	1210	910	1180	680	0			SD2-63-6
350KQW1400-26-132/4	1680	1110	990	4-φ25	235	320	950	810	1225	880	1030	580	5			SD2-63-6
350KQW1500-30-160/4	1680	1110	990	4-φ25	235	320	950	810	1225	880	1030	580	5			SD2-63-6
350KQW1500-38-200/4	1680	1110	990	4-φ25	235	320	950	810	1225	880	1030	580	5			SD2-63-6
350KQW1500-45-250/4	1846	1193	990	4-φ25	235	320	1150	810	1355	880	1001	551	25			SD2-63-6

一、底板与基础直接联接(不带L型联接板)

I. Baseplate connected with base directly (without L type of connection board)

底板代号 Baseplate code (尺寸详见各尺寸图) (Dimensions appear in each figure)	φd1	硬性联接基础尺寸图 Basic figure for rigid joint dimensions						地脚螺栓 GB799-88
		H	E	F	A	d	h	
KQN-1	14	200	360	400	160	60	200	M12×220
KQN-2	14	200	400	450	210	60	200	
KQN-3	18	300	500	550	290	80	300	
KQN-4	18	300	600	650	360	80	300	M16×300
KQN-5	22	300	650	700	400	80	300	
KQN-6	22	300	800	900	450	80	300	
KQN-7	22	300	1000	1100	550	80	300	

二、配L型联接板安装

II. Mounted with L type of connection board

L型联接板尺寸 Dimensions of L type of connection board						硬性联接基础尺寸图 Basic figure for rigid joint dimensions						地脚螺栓
型号 Type	C2xB2	A	B	Φd1	Φd2	H	E	F	A	Φd	h	地脚螺栓
L-0	60x100	240	300	14	14	200	450	500	240	60	200	GB799-88
L-1	160x160	240	300	14	14	200	450	500	240	60	200	M12×220
L-2	210x210	340	400	14	14	200	650	700	340	80	200	M16×300
L-3	290x290	440	500	18	18	300	750	800	440	80	300	
L-4	360x360	540	600	18	18	300	850	900	540	80	300	
L-5	400x400	640	700	22	22	300	950	1000	640	80	300	M20×300
L-6	450x450	740	800	22	22	350	1000	1100	740	80	300	
L-7	550x550	840	900	22	22	350	1200	1300	840	80	300	

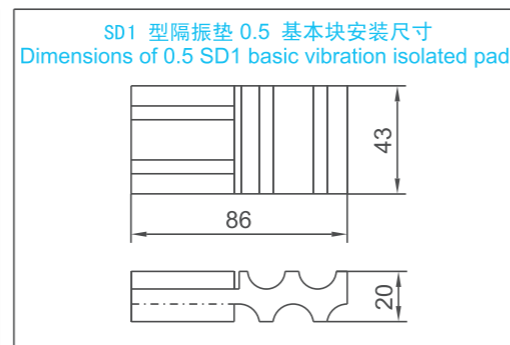
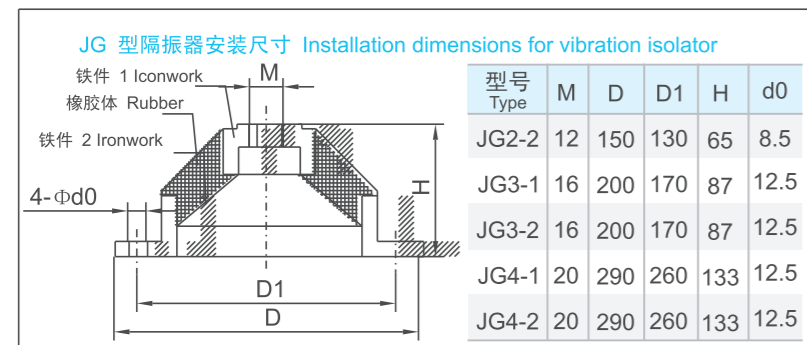

注： 1. 本公司产品经精心加工装配，振动小。故建议一般不采用安装隔振器、隔振垫。各尺寸图中所注隔振器（垫）规格为推荐规格。
 2. 一般情况下，推荐采用底板与基础直接联接方式。
 Note: 1. Kaiquan product features less vibration due to elaborate machinery and assembly. It is recommended not to employ vibration isolator or isolated pads. The specifications of each dimension figure are recommended.
 2. In general it is recommended to baseplate connected with base directly

INSTALLATION MODE
KQL允许的安装方式

1. 直接安装（7.5KW以下）
Direct installation

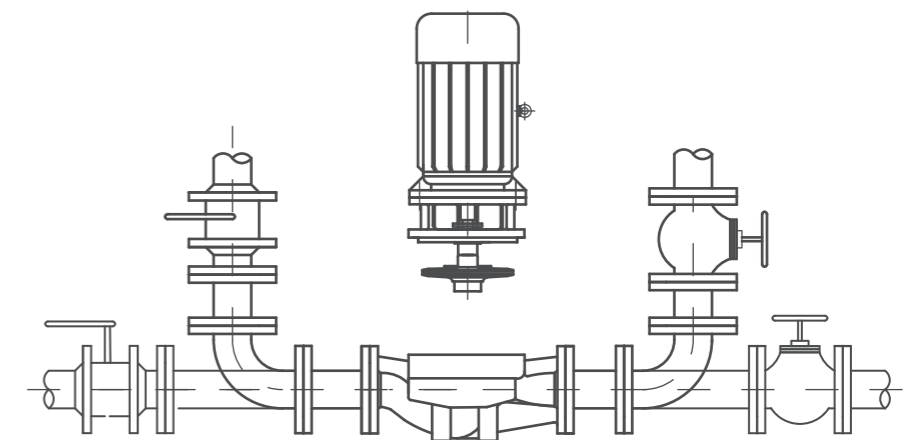
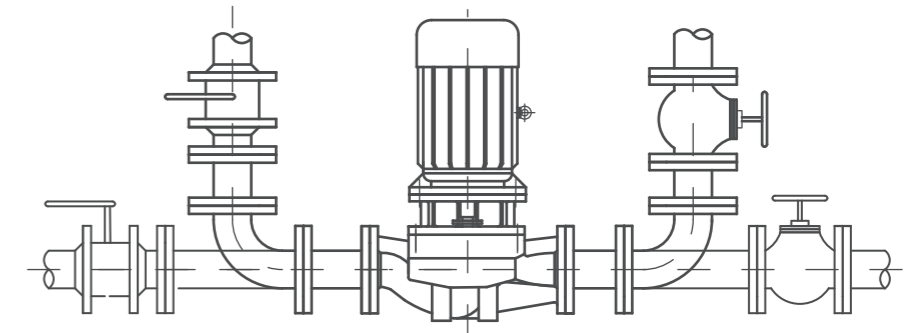

2. 地基支撑硬性联接
Rigid joint with base support

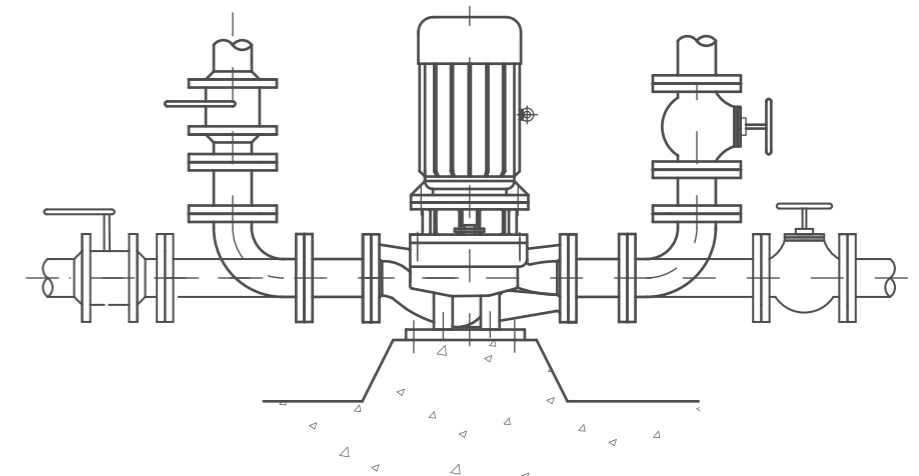

3. 地基支撑柔性联接
Flexible joint with base support

3.1 配减振台加隔振器
Installed with damping platform and vibration isolator

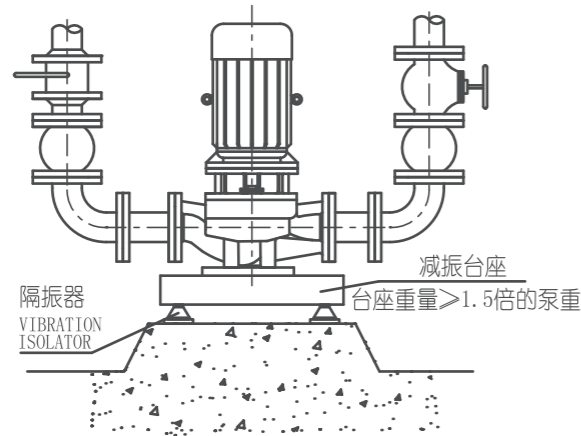

3.2 配底板加隔振垫
Installed with baseplate and vibration isolated pads

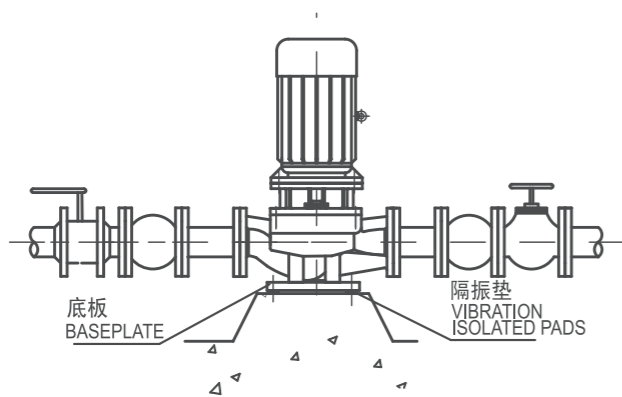

4. 悬臂卧式安装 (7.5KW以下)
Cantilever horizontal

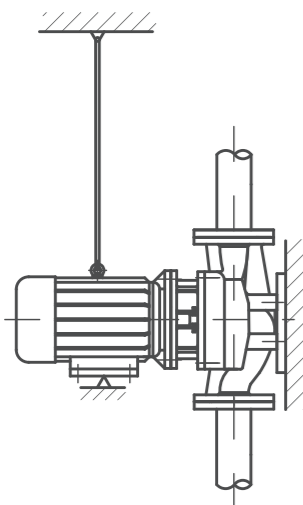

5. 户外使用: 采用户外电机
For outdoor usage: Adopt outdoor type motor

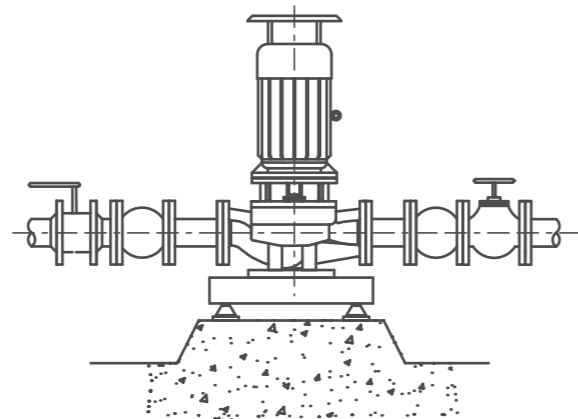

CHART
与原型号对照表

序号	型号	原型号	序号	型号	原型号
1	50KQL/W11-10-0.75/2	50/90-0.75/2	49	100KQL/W100-12.5-5.5/2	100/100-5.5/2
2	50KQL/W12.5-12.5-1.1/2	50/100-1.1/2	50	100KQL/W85-16-5.5/2	100/110S-5.5/2
3	50KQL/W11-16-1.1/2	50/110-1.1/2	51	100KQL/W95-20-7.5/2	100/125S-7.5/2
4	50KQL/W12.5-20-1.5/2	50/125-1.5/2	52	100KQL/W80-24-7.5/2	100/140S-7.5/2
5	50KQL/W10-27-1.5/2	50/150S-1.5/2	53	100KQL/W94-28-11/2	100/150-11/2
6	50KQL/W12.5-32-2.2/2	50/160S-2.2/2	54	100KQL/W100-32-15/2	100/160-15/2
7	50KQL/W10-36-3/2	50/170S-3/2	55	100KQL/W115-34-15/2	100/165-15/2
8	50KQL/W12-44-4/2	50/185S-4/2	56	100KQL/W94-44-18.5/2	100/185-18.5/2
9	50KQL/W12.5-50-5.5/2	50/200S-5.5/2	57	100KQL/W100-50-22/2	100/200-22/2
10	65KQL/W22-10-1.1/2	65/90-1.1/2	58	100KQL/W87-60-30/2	100/220-30/2
11	65KQL/W25-12.5-1.5/2	65/100-1.5/2	59	100KQL/W94-70-30/2	100/235-30/2
12	65KQL/W22-16-2.2/2	65/110-2.2/2	60	100KQL/W100-80-37/2	100/250-37/2
13	65KQL/W25-20-2.2/2	65/125S-2.2/2	61	100KQL/W82-85-37/2	100/270-37/2
14	65KQL/W20-24-2.2/2	65/140S-2.2/2	62	100KQL/W90-101-45/2	100/285-45/2
15	65KQL/W23-28-3/2	65/150S-3/2	63	100KQL/W95-113-55/2	100/300-55/2
16	65KQL/W25-32-4/2	65/160-4/2	64	100KQL/W100-125-75/2	100/315-75/2
17	65KQL/W22-38-5.5/2	65/170S-5.5/2	65	100KQL/W50-8-2.2/4	100/160-2.2/4
18	65KQL/W23-44-5.5/2	65/185S-5.5/2	66	100KQL/W45-10-2.2/4	100/185-2.2/4
19	65KQL/W25-50-7.5/2	65/200S-7.5/2	67	100KQL/W50-12.5-3/4	100/200-3/4
20	80KQL/W45-10-2.2/2	80/90-2.2/2	68	100KQL/W47-17-4/4	100/235-4/4
21	80KQL/W50-12.5-3/2	80/100-3/2	69	100KQL/W50-20-5.5/4	100/250-5.5/4
22	80KQL/W45-16-3/2	80/110S-3/2	70	100KQL/W47-28-7.5/4	100/300-7.5/4
23	80KQL/W50-20-4/2	80/125S-4/2	71	100KQL/W50-32-11/4	100/315-11/4
24	80KQL/W40-24-4/2	80/140S-4/2	72	125KQL/W143-10-7.5/2	125/90-7.5/2
25	80KQL/W47-28-5.5/2	80/150S-5.5/2	73	125KQL/W160-12.5-11/2	125/100-11/2
26	80KQL/W50-32-7.5/2	80/160-7.5/2	74	125KQL/W143-16-11/2	125/110-11/2
27	80KQL/W35-34-5.5/2	80/165-5.5/2	75	125KQL/W160-20-15/2	125/125-15/2
28	80KQL/W44-38-7.5/2	80/170-7.5/2	76	125KQL/W138-24-15/2	125/140-15/2
29	80KQL/W47-44-11/2	80/185-11/2	77	125KQL/W150-28-18.5/2	125/150-18.5/2
30	80KQL/W50-50-15/2	80/200-15/2	78	125KQL/W160-32-22/2	125/160-22/2
31	80KQL/W43-60-15/2	80/220-15/2	79	125KQL/W138-38-22/2	125/170-22/2
32	80KQL/W47-70-18.5/2	80/235-18.5/2	80	125KQL/W150-44-30/2	125/185-30/2
33	80KQL/W50-80-22/2	80/250-22/2	81	125KQL/W160-50-37/2	125/200-37/2
34	80KQL/W40-85-22/2	80/270-22/2	82	125KQL/W138-60-37/2	125/220-37/2
35	80KQL/W43-101-30/2	80/285-30/2	83	125KQL/W150-70-45/2	125/235-45/2
36	80KQL/W47-113-30/2	80/300-30/2	84	125KQL/W160-80-55/2	125/250-55/2
37	80KQL/W50-125-37/2	80/315-37/2	85	125KQL/W134-88-55/2	125/270-55/2
38	80KQL/W25-20-3/4	80/250-3/4	86	125KQL/W143-100-75/2	125/285-75/2
39	80KQL/W23-28-4/4	80/300-4/4	87	125KQL/W150-110-75/2	125/300-75/2
40	80KQL/W25-32-5.5/4	80/315-5.5/4	88	125KQL/W160-125-90/2	125/315-90/2
41	100KQL/W60-16-4/2	100/110-4/2(Z)	89	125KQL/W100-5-2.2/4	125/125-2.2/4
42	100KQL/W70-20-5.5/2	100/125-5.5/2(Z)	90	125KQL/W87-6-3/4	125/150-3/4
43	100KQL/W70-26-7.5/2	100/150-7.5/2(Z)	91	125KQL/W100-8-4/4	125/160-4/4
44	100KQL/W75-32-11/2	100/160-11/2(Z)	92	125KQL/W100-12.5-5.5/4	125/200-5.5/4
45	100KQL/W68-38-11/2	100/170-11/2(Z)	93	125KQL/W87-15-5.5/4	125/220-5.5/4
46	100KQL/W72-44-15/2	100/185-15/2(Z)	94	125KQL/W93-17-7.5/4	125/235-7.5/4
47	100KQL/W75-50-18.5/2	100/200-18.5/2(Z)	95	125KQL/W120-16-7.5/4	125/235(I)-7.5/4
48	100KQL/W89-10-4/2	100/90-4/2	96	125KQL/W100-20-11/4	125/250-11/4

CHART
与原型号对照表

序号	型号	原型号	序号	型号	原型号
97	125KQL/W79-20-7.5/4	125/285-7.5/4	145	200KQL/W340-24-30/4	200/285S-30/4
98	125KQL/W91-27-11/4	125/300-11/4	146	200KQL/W360-28-37/4	200/300S-37/4
99	125KQL/W100-32-15/4	125/315-15/4	147	200KQL/W390-32-45/4	200/315S-45/4
100	125KQL/W87-38-18.5/4	125/345-18.5/4	148	200KQL/W440-32-55/4	200/315-55/4
101	125KQL/W94-44-22/4	125/370-22/4	149	200KQL/W340-36-45/4	200/345S-45/4
102	125KQL/W100-50-30/4	125/400-30/4	150	200KQL/W370-40-55/4	200/350-55/4
103	150KQL/W140-20-11/4	150/250-11/4(Z)	151	200KQL/W374-44-75/4	200/370-75/4
104	150KQL/W160-24-15/4	150/285-15/4(Z)	152	200KQL/W400-50-75/4	200/400-75/4
105	150KQL/W150-28-18.5/4	150/300-18.5/4(Z)	153	200KQL/W346-60-90/4	200/410-90/4
106	150KQL/W160-32-22/4	150/315-22/4(Z)	154	200KQL/W374-70-110/4	200/435-110/4
107	150KQL/W138-38-22/4	150/345-22/4(Z)	155	200KQL/W400-80-132/4	200/460-132/4
108	150KQL/W150-44-30/4	150/370-30/4(Z)	156	250KQL/W490-17-30/4	250/235S-30/4
109	150KQL/W160-50-37/4	150/400-37/4(Z)	157	250KQL/W520-20-37/4	250/250S-37/4
110	150KQL/W179-10-11/4	150/185-11/4	158	250KQL/W500-25-45/4	250/290-45/4
111	150KQL/W200-12.5-11/4	150/200S-11/4	159	250KQL/W500-28-55/4	250/300-55/4
112	150KQL/W180-16-11/4	150/235S-11/4	160	250KQL/W550-32-75/4	250/315-75/4
113	150KQL/W200-20-15/4	150/250S-15/4	161	250KQL/W500-41-75/4N	250KQL/W500-41-75/4
114	150KQL/W173-24-18.5/4	150/285-18.5/4	162	250KQL/W500-44-90/4N	250KQL/W500-44-90/4
115	150KQL/W200-28-22/4	150/290-22/4	163	250KQL/W500-50-90/4N	250KQL/W500-50-90/4
116	150KQL/W200-32-30/4	150/315-30/4	164	250KQL/W600-50-110/4N	250KQL/W600-50-110/4
117	150KQL/W240-32-30/4	150/315(I)-30/4	165	250KQL/W480-60-132/4	250/410-132/4
118	150KQL/W200-38-30/4	150/350-30/4	166	250KQL/W515-70-160/4	250/435-160/4
119	150KQL/W187-44-37/4	150/370-37/4	167	250KQL/W550-80-200/4	250/460-200/4
120	150KQL/W200-50-45/4	150/400-45/4	168	300KQL/W660-18-45/4	300-200A-45/4
121	150KQL/W173-60-55/4	150/410-55/4	169	300KQL/W720-20-55/4	300-200-55/4
122	150KQW180-70-55/2	KQW150/235-55/2	170	300KQL/W600-24-55/4	300-315B-55/4
123	150KQL/W187-70-75/4	150/435-75/4	171	300KQL/W660-28-75/4	300-315A-75/4
125	150KQW200-80-75/2	KQW150/250-75/2	172	300KQL/W720-32-90/4	300-315-90/4
125	150KQL/W200-80-75/4	150/460-75/4	173	300KQL/W600-38-90/4	300-400B-90/4(N)
126	200KQL/W280-10-11/4	200/185S-11/4(Z)	174	300KQL/W660-44-110/4	300-400A-110/4(N)
127	200KQL/W300-12.5-15/4	200/200S-15/4(Z)	175	300KQL/W720-50-132/4	300-400-132/4(N)
128	200KQL/W280-16-18.5/4	200/235-18.5/4(Z)	176	300KQW620-60-160/4	300-500B-160/4
129	200KQL/W300-20-22/4	200/250S-22/4(Z)	177	300KQW670-70-200/4	300-500A-200/4
130	200KQL/W245-24-22/4	200/285S-22/4(Z)	178	300KQW720-80-250/4	300-500-250/4
131	200KQL/W280-28-30/4	200/300S-30/4(Z)	179	300KQL/W1000-24-110/4	350KQL/W1000-24-110/4
132	200KQL/W300-32-37/4	200/315S-37/4(Z)	180	300KQL/W1100-28-132/4	350KQL/W1100-28-132/4
133	200KQL/W260-38-45/4	200/345-45/4(Z)	181	300KQL/W1200-32-160/4	350KQL/W1200-32-160/4
134	200KQL/W270-44-45/4	200/370S-45/4(Z)	182	300KQW1050-38-160/4	350KQW1050-38-160/4
135	200KQL/W300-48-55/4	200/400S-55/4(Z)	183	300KQW1130-44-200/4	350KQW1130-44-200/4
136	200KQL/W262-60-75/4	200/410-75/4(Z)	184	300KQW1200-48-200/4	350KQW1200 50 250/4
137	200KQW262-70-75/2	KQW200/235-75/2	185	300KQL/W800-36-110/4	350KQL/W820-38-132/4
138	200KQL/W280-70-90/4	200/435-90/4(Z)	186	300KQL/W900-40-132/4	350KQL/W860-44-160/4
139	200KQW290-80-90/2	KQW200/250-90/2	187	300KQL/W900-50-160/4	350KQL/W960-50-200/4
140	200KQL/W300-80-110/4	200/460-110/4(Z)	原DN350系列降口径设计		
141	200KQL/W358-10-15/4	200/185S-15/4			
142	200KQL/W400-12.5-18.5/4	200/200S-18.5/4			
143	200KQL/W358-16-22/4	200/235-22/4			
144	200KQL/W400-20-30/4	200/250-30/4			